

SUPER ERECTA SHELF® POST-MOUNTED TYPE

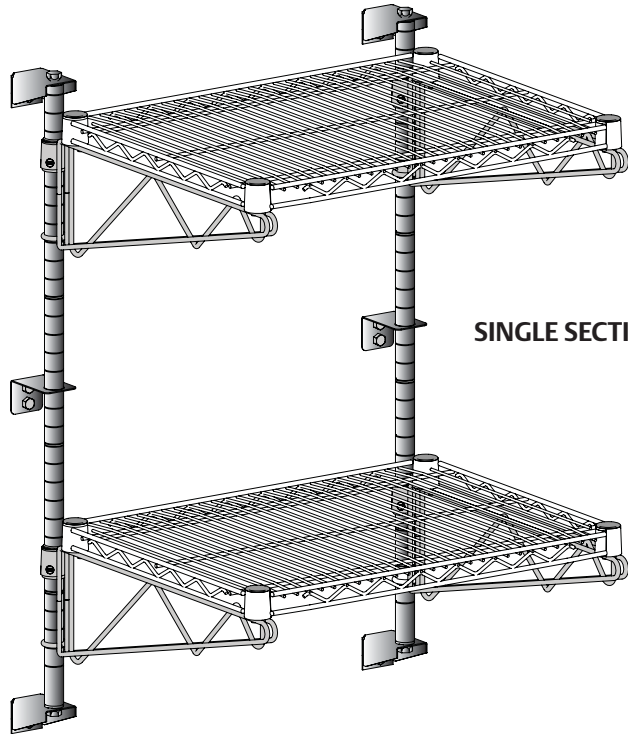

SINGLE SECTION UNIT

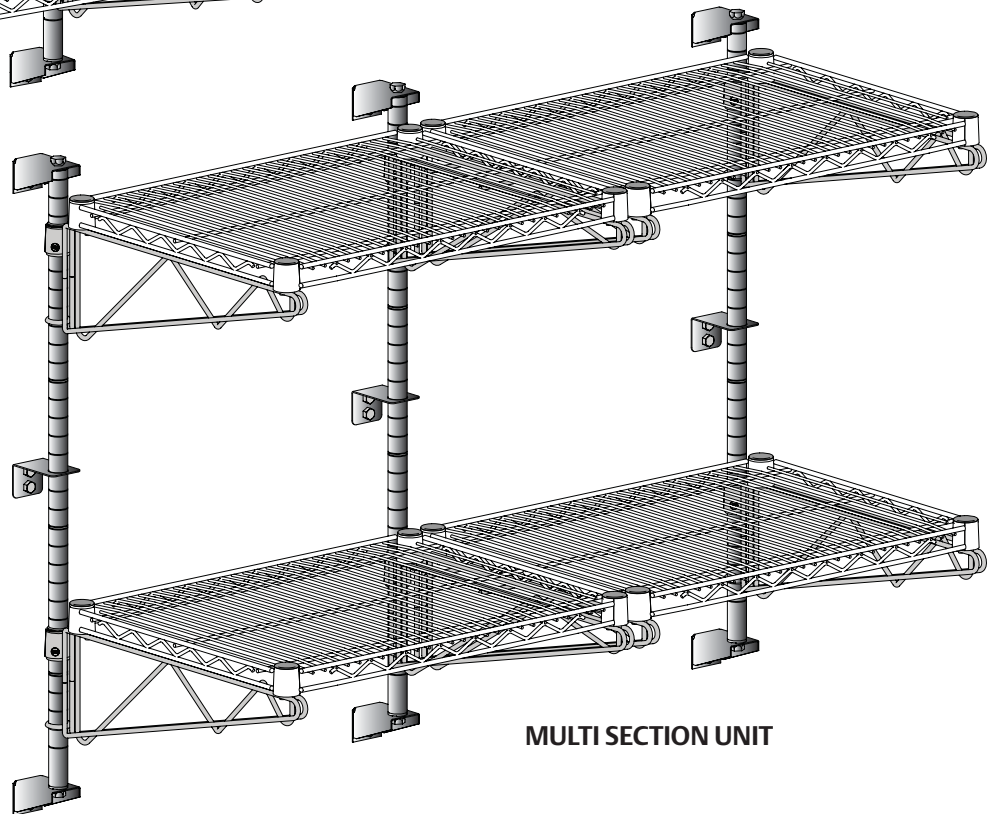

MULTI SECTION UNIT

DESCRIPTION

SES Post-Mounted Type - hole location diagram, single and multi section units assembly procedure

Instructions For Use

Two People Required to Assemble Unit.

**SINGLE SECTION UNIT
Mounting Hole Location Diagram**

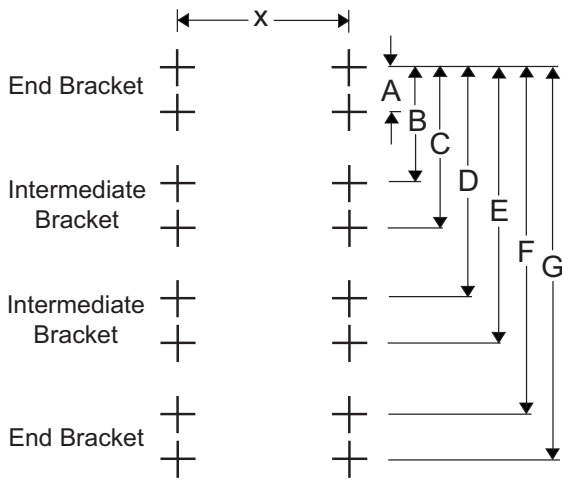

NUMBER OF TIERS	A	B	C	D	E	F	G
1	$\frac{7}{8}$	-	-	-	-	14	$14\frac{7}{8}$
2	$\frac{7}{8}$	$16\frac{7}{8}$	$17\frac{3}{4}$	-	-	34	$34\frac{7}{8}$
3	$\frac{7}{8}$	$17\frac{11}{16}$	$18\frac{9}{16}$	$39\frac{11}{16}$	$40\frac{9}{16}$	$54\frac{1}{16}$	$54\frac{15}{16}$
4	$\frac{7}{8}$	$15\frac{11}{16}$	$16\frac{9}{16}$	$31\frac{11}{16}$	$32\frac{9}{16}$	$62\frac{1}{16}$	$62\frac{15}{16}$
SHELF SIZE							
	24	30	36	42	48	60	72
X	$22\frac{7}{16}$	$28\frac{7}{16}$	$34\frac{7}{16}$	$40\frac{7}{16}$	$46\frac{7}{16}$	$58\frac{7}{16}$	$70\frac{7}{16}$

Shelf Location Chart

NUMBER OF TIERS	1ST SHELF LOCATION	2ND SHELF LOCATION	3RD SHELF LOCATION	4TH SHELF LOCATION
1	Groove # 9	--	--	--
2	Groove # 9	Groove # 31	--	--
3	Groove # 9	Groove # 31	Groove # 52	--
4	Groove # 9	Groove # 31	Groove # 43	Groove # 60

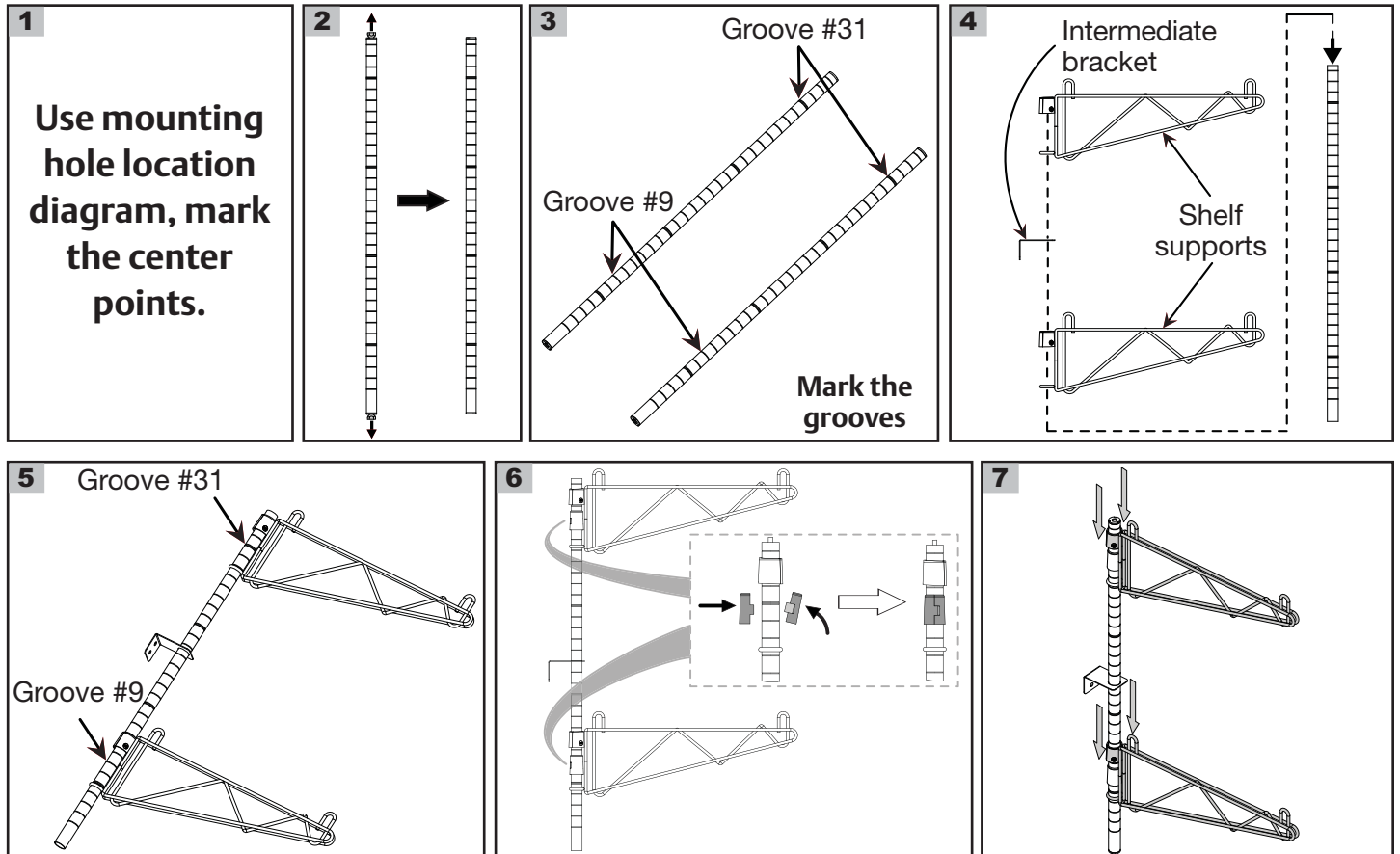

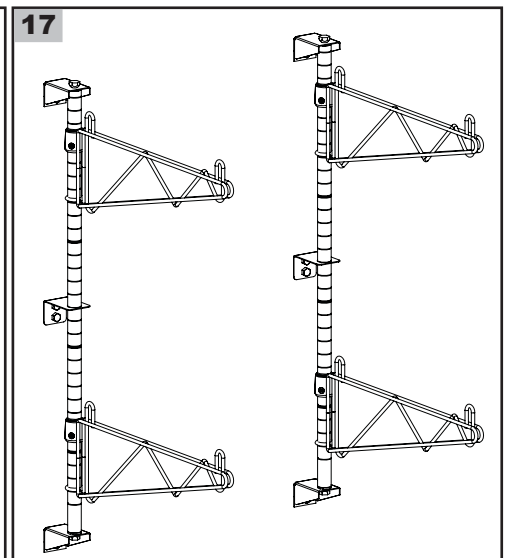
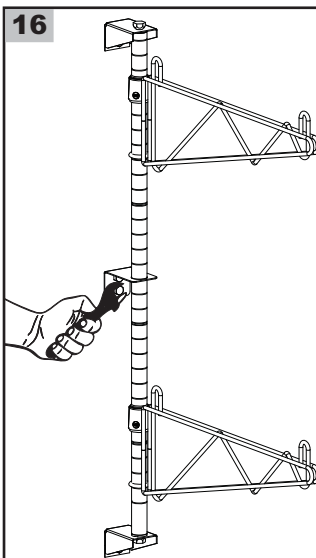
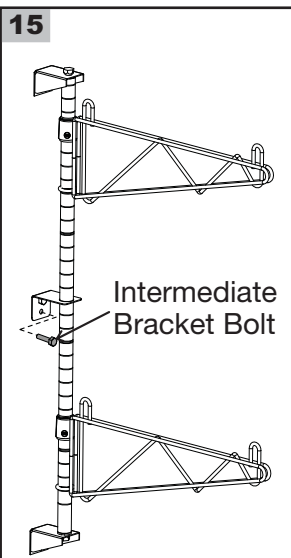
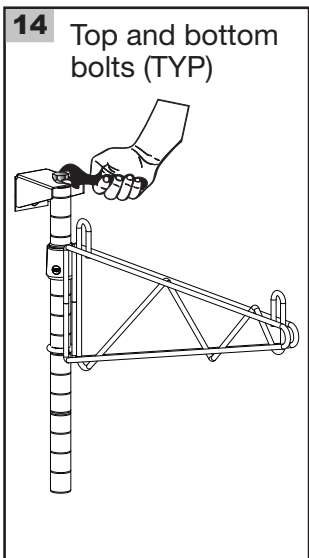
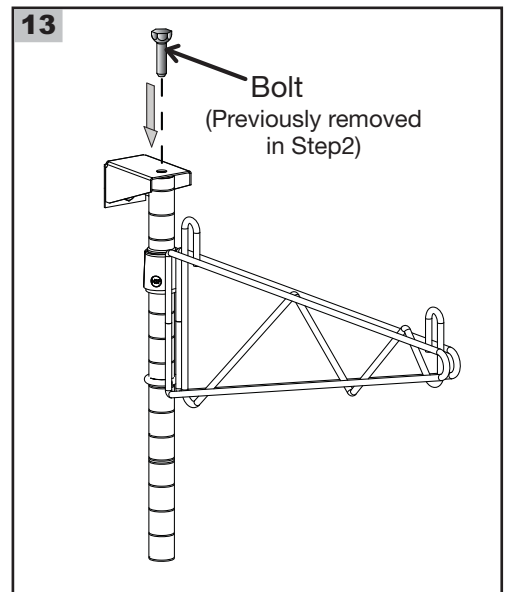
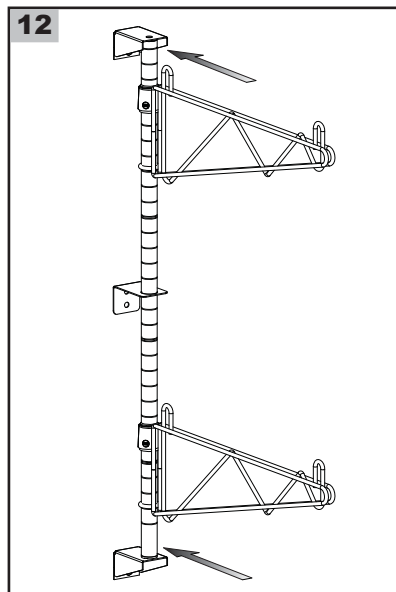
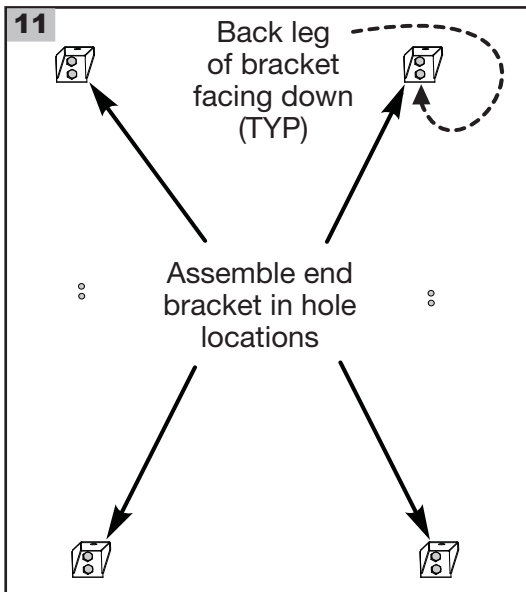
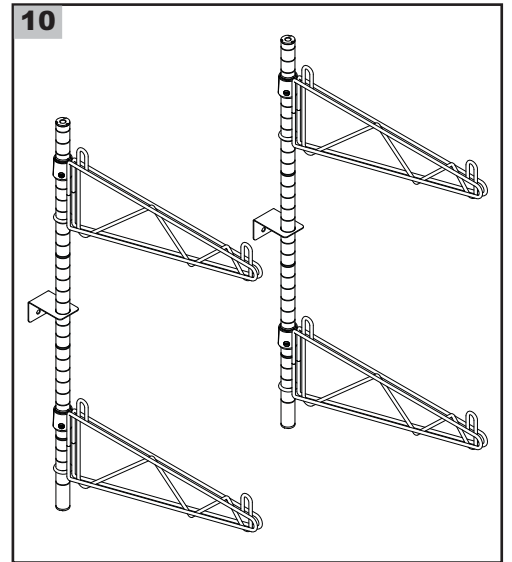
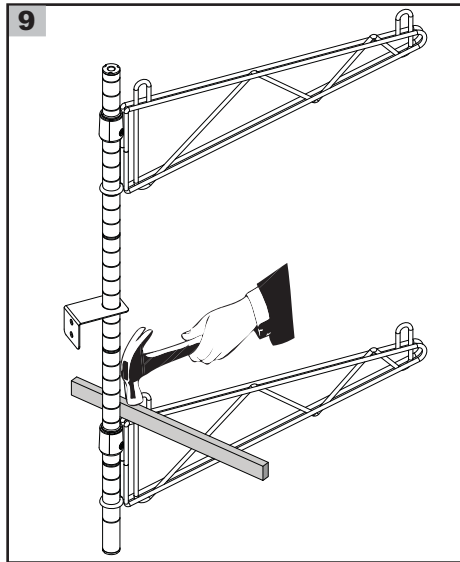
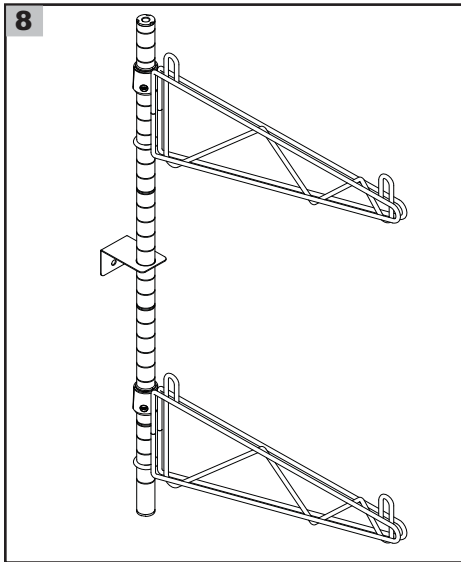

SES Post-Mounted Type

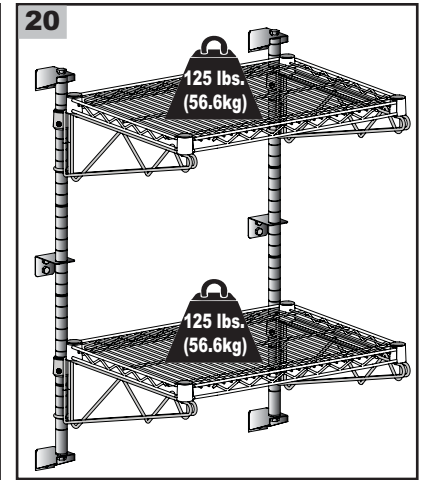
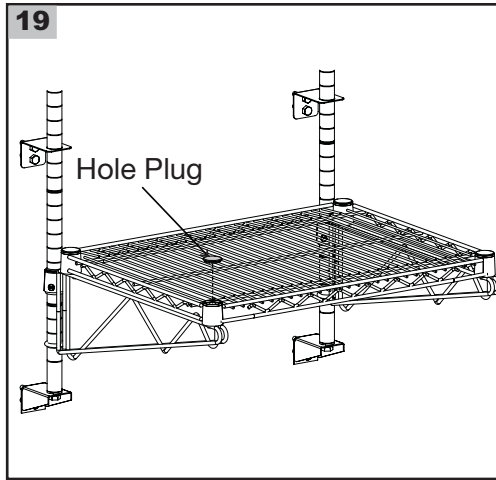
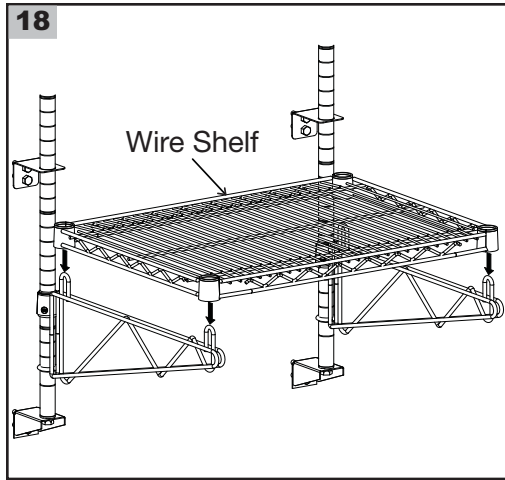

THIS COMPLETES THE ASSEMBLY OF POST MOUNTED TYPE SES SHELF



Maximum capacities are based on evenly distributed load.
 Capacity per shelf must not exceed 250lbs. (113kg).
 Capacity of single level multi section unit must not exceed 250 lbs (113kg) total.

MULTI SECTION UNIT Mounting Hole Location Diagram

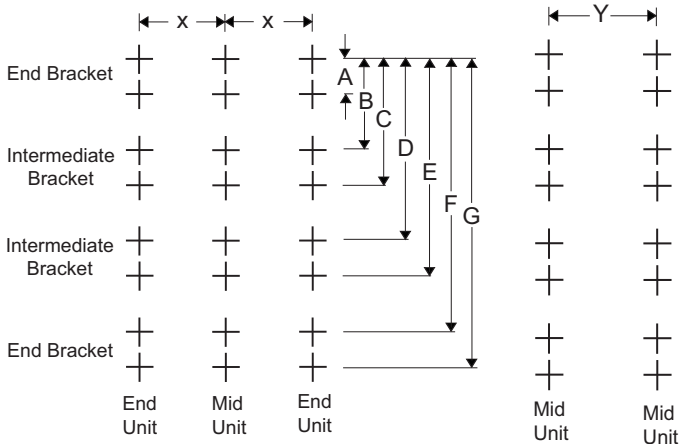

NUMBER OF TIERS	A	B	C	D	E	F	G
1	7/8	-	-	-	-	14	14 7/8
2	7/8	16 7/8	17 3/4	-	-	34	34 7/8
3	7/8	17 11/16	18 9/16	39 11/16	40 9/16	54 1/16	54 15/16
4	7/8	15 11/16	16 9/16	31 11/16	32 9/16	62 1/16	62 15/16
SHELF SIZE							
	24	30	36	42	48	60	72
X	23 3/16	29 3/16	35 3/16	41 3/16	47 3/16	59 3/16	71 3/16

Shelf Location Chart

NUMBER OF TIERS	1ST SHELF LOCATION	2ND SHELF LOCATION	3RD SHELF LOCATION	4TH SHELF LOCATION
1	Groove # 9	--	--	--
2	Groove # 9	Groove # 31	--	--
3	Groove # 9	Groove # 31	Groove # 52	--
4	Groove # 9	Groove # 31	Groove # 43	Groove # 60

SHELF SIZE	24	30	36	42	48	60	72
Y	23 15/16	29 15/16	35 15/16	41 15/16	47 15/16	59 15/16	71 15/16

FOLLOW STEPS 2-20 FOR ASSEMBLING MULTI SECTION UNITS



Maximum capacities are based on evenly distributed load.
 Capacity per shelf must not exceed 250lbs. (113kg).
 Capacity of double level multi section unit must not exceed 250 lbs (113kg) total.

* Save this document for future application, load rating and/or safety reference.



US/Can: 1.800.992.1776
 Corporate Headquarters (US): 1.570.825.2741
 For Inquiries Outside of the U.S. and Canada, Visit www.metro.com/contactus