

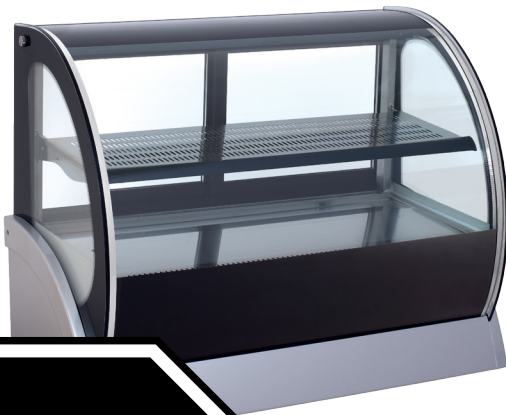

## Refrigerated Showcases

Models RS-CN-0115-R, 0155-R, 0200-R, 0115-F, 0155-F, 0200-F  
Items 31406, 31815, 31818, 31865, 31866, 31867

## Instruction Manual



*Revised - 08/19/2022*



Toll Free: 1-800-465-0234  
Fax: 905-607-0234  
Email: [service@omcan.com](mailto:service@omcan.com)  
[www.omcan.com](http://www.omcan.com)

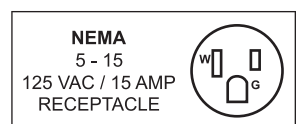

# ***Table of Contents***

Model RS-CN-0115-R / Model RS-CN-0155-R / Model RS-CN-0200-R  
Model RS-CN-0115-F / Model RS-CN-0155-F / Model RS-CN-0200-F

---

<b>Section</b>	<b>Page</b>
Disclaimer -----	3
General Information -----	4 - 5
Safety and Warranty -----	5 - 6
Technical Specifications -----	7
Installation -----	8
Operation -----	9 - 10
Maintenance -----	10 - 11
Troubleshooting -----	11 - 12
Parts Breakdown -----	13 - 17
Electrical Schematics -----	18
Warranty Registration -----	19

## *Disclaimer*

---

***OMCAN IS NOT RESPONSIBLE FOR ANY DAMAGES DUE TO WATER LEAKS. WARRANTY FOR WATER LEAKS IS VOID IF THE AMBIENT ROOM TEMPERATURE EXCEEDS 75°F AND 55% RELATIVE HUMIDITY, AND THE APPLIANCE DRAIN IS NOT CONNECTED DIRECTLY TO A FLOOR DRAIN.***

# **General Information**

---

**Omcan Manufacturing and Distributing Company Inc., Food Machinery of America, Inc. dba Omcan and Omcan Inc. are not responsible for any harm or injury caused due to any person's improper or negligent use of this equipment. The product shall only be operated by someone over the age of 18, of sound mind, and not under the influence of any drugs or alcohol, who has been trained in the correct operation of this machine, and is wearing authorized, proper safety clothing. Any modification to the machine voids any warranty, and may cause harm to individuals using the machine or in the vicinity of the machine while in operation.**

## **CHECK PACKAGE UPON ARRIVAL**

Upon receipt of an Omcan shipment please inspect for external damage. If no damage is evident on the external packaging, open carton to ensure all ordered items are within the box, and there is no concealed damage to the machine. If the package has suffered rough handling, bumps or damage (visible or concealed), please note it on the bill of lading before accepting the delivery and contact Omcan within 24 hours, so we may initiate a claim with the carrier. A detailed report on the extent of the damage caused to the machine must be filled out within three days, from the delivery date shown in the shipping documents. Omcan has no recourse for damaged products that were shipped collect or third party.

**Before operating any equipment, always read and familiarize yourself with all operation and safety instructions.**

**Omcan would like to thank you for purchasing this machine. It's of the utmost importance to save these instructions for future reference. Also save the original box and packaging for shipping the equipment if servicing or returning of the machine is required.**

---

**Omcan Fabrication et distribution Compañie Limité et Food Machinery d'Amérique, dba Omcan et Omcan Inc. ne sont pas responsables de tout dommage ou blessure causé du fait que toute personne ait utilisé cet équipement de façon irrégulière. Le produit ne doit être exploité que par quelqu'un de plus de 18 ans, saine d'esprit, et pas sous l'influence d'une drogue ou d'alcool, qui a été formé pour utiliser cette machine correctement, et est vêtu de vêtements de sécurité approprié. Toute modification de la machine annule toute garantie, et peut causer un préjudice à des personnes utilisant la machine ou des personnes à proximité de la machine pendant son fonctionnement.**

## **VÉRIFIEZ LE COLIS DÈS RÉCEPTION**

Dès réception d'une expédition d'Omcan veuillez inspecter pour dommages externes. Si aucun dommage n'est visible sur l'emballage externe, ouvrez le carton afin de s'assurer que tous les éléments commandés sont dans la boîte, et il n'y a aucun dommage dissimulé à la machine. Si le colis n'a subi aucune mauvaises manipulations, de bosses ou de dommages (visible ou cachée), notez-le sur le bond de livraison avant d'accepter la livraison et contactez Omcan dans les 24 heures qui suivent, pour que nous puissions engager une réclamation auprès du transporteur. Un rapport détaillé sur l'étendue des dommages causés à la machine doit être rempli dans un délai de trois jours, à compter de la date de livraison indiquée dans les documents d'expédition. Omcan n'a aucun droit de recours pour les produits endommagés qui ont été expédiés ou cueilli par un tiers transporteur.

# General Information

---

Avant d'utiliser n'importe quel équipement, toujours lire et vous familiariser avec toutes les opérations et les consignes de sécurité.

Omcan voudrais vous remercier d'avoir choisi cette machine. Il est primordial de conserver ces instructions pour une référence ultérieure. Également conservez la boîte originale et l'emballage pour l'expédition de l'équipement si l'entretien ou le retour de la machine est nécessaire.

Omcan Empresa De Fabricacion Y Distribucion Inc. Y Maquinaria De Alimentos De America, Inc. dba Omcan y Omcan Inc. no son responsables de ningun daño o perjuicio causado por cualquier persona inadecuada o el uso descuidado de este equipo. El producto solo podra ser operado por una persona mayor de 18 años, en su sano juicio y no bajo alguna influencia de droga o alcohol, y que este ha sido entrenado en el correcto funcionamiento de esta máquina, y ésta usando ropa apropiada y autorizada. Cualquier modificación a la máquina anula la garantía y puede causar daños a las personas usando la máquina mientras esta en el funcionamiento.

## REVISE EL PAQUETE A SU LLEGADA

Tras la recepcion de un envio Omcan favor inspeccionar daños externos. Si no hay daños evidentes en el empaque exterior, Habra el carton para asegurarse que todos los articulos solicitados estén dentro de la caja y no encuentre daños ocultos en la máquina. Si el paquete ha sufrido un manejo de poco cuidado, golpes o daños (visible o oculto) por favor anote en la factura antes de aceptar la entrega y contacte Omcan dentro de las 24 horas, de modo que podamos iniciar una reclamación con la compañía. Un informe detallado sobre los daños causados a la máquina debe ser llenado en el plazo de tres días, desde la fecha de entrega que se muestra en los documentos de envío. Omcan no tiene ningun recurso por productos dañados que se enviaron a recoger por terceros.

Antes de utilizar cualquier equipo, siempre lea y familiarizarse con todas las instrucciones de funcionamiento y seguridad.

Omcan le gustaría darle las gracias por la compra de esta máquina. Es de la mayor importancia para salvar estas instrucciones para futuras consultas. Además, guarda la caja original y el embalaje para el envío del equipo si servicio técnico o devolución de la máquina que se requiere.

# Safety and Warranty

---

1. This unit is a showcase refrigeration, objects placed in this unit should already be cooled.
2. This instruction manual must be read before operating the unit and must be kept for future reference.
3. **WARNING:** Never use this unit for applications which are not described in the instructions or under conditions which are not similar to those described in the instructions. Otherwise, sever injuries may occur.
4. This unit should only be used for the purpose for which it was designed. Any other use is inappropriate and therefore dangerous. Omcan will not be held responsible for any damage caused by improper use.
5. Before installing and operating the machine, carefully read this manual.

# ***Safety and Warranty***

---

6. Keep the unit out of reach of children. Do not allow children to play with the unit.
7. Unplug the unit from the outlet when not in use, before assembly or disassembly and before cleaning.
8. Be sure to unplug the unit if not using for a long period of time.
9. If the supply cord is damaged, the cord should be replaced by the manufacturer, authorized service agent or similarly qualified persons.
10. Do not use the unit in a dusty environment or flammable or explosive substances.
11. Disable the unit immediately if defective. Dispose of the unit according to the regulations of local law. Please see instructions for disposal in this manual.
12. Other than cleaning mentioned in this instruction manual, no additional maintenance or servicing of this unit is required.
13. The motor is permanently lubricated and will require no oil.
14. Repairs, when necessary, must be performed at an authorized service facility.
15. The unit is suitable for indoor use only.
16. Basic safety rules:
  - Do not touch the unit when hands or feet are wet.
  - Do not use the unit when barefoot.
  - Do not allow the unit to be used by children or untrained persons.
  - Do not leave the unit outside.
  - Do not pull on the electrical cord when unplugging the unit.
  - Omcan reserves the right to modify the construction or appearance of the unit without notice.

**RESIDENTIAL USERS: Vendor assumes no liability for parts or labor coverage for component failure or other damages resulting from installation in non-commercial or residential applications. The right is reserved to deny shipment for residential usage; if this occurs, you will be notified as soon as possible.**

## **1 YEAR PARTS AND LABOR WARRANTY**

**Within the warranty period, contact Omcan Inc. at 1-800-465-0234 to schedule an Omcan authorized service technician to repair the equipment locally.**

**Unauthorized maintenance will void the warranty. Warranty covers electrical and part failures, not improper use.**

**Please see <https://omcan.com/disclaimer> for complete info.**

### **WARNING:**

The packaging components (cardboard, polyethylene, and others) are classified as normal solid urban waste and can therefore be disposed of without difficulty.

**In any case, for suitable recycling, we suggest disposing of the products separately (differentiated waste) according to the current norms.**

**DO NOT DISCARD ANY PACKAGING MATERIALS IN THE ENVIRONMENT!**



# Technical Specifications

## COUNTERTOP COLD DELI SHOWCASES

Model	RS-CN-0115-R	RS-CN-0155-R	RS-CN-0200-R
Temperature Range	2 - 8°C / 35.6 - 46.4°F		
Max Ambient Temp Rating	24°C / 75°F		
Capacity	115 L / 4 cu.ft.	155 L / 5.47 cu.ft.	200 L / 7 cu.ft.
Power	0.420 kW	0.453 kW	0.479 kW
Current	4.82A	4.58A	4.84A
Refrigerant	R134a, 185g	R134a, 270g	R134a, 300g
Number of Shelves	2		
Electrical	110V / 60Hz / 1		
Interior Dimensions	15.8" x 35.5" x 14.5" 400 x 902 x 368mm	15.8" x 47.3" x 14.5" 400 x 1200 x 368mm	15.8" x 59" x 14.5" 400 x 1499 x 368mm
Dimensions	21.3" x 35.5" x 31" 540 x 902 x 787mm	21.3" x 47.3" x 31" 540 x 1200 x 787mm	21.3" x 59" x 31" 540 x 1499 x 787mm
Packaging Dimensions	39.8" x 25.4" x 40" 1010 x 645 x 1016mm	51.8" x 25.4" x 40" 1314 x 645 x 1016mm	63.4" x 25.4" x 40" 1610 x 645 x 1016mm
Weight	209.5 lbs. / 95 kgs.	231.5 lbs. / 105 kgs.	264.5 lbs. / 120 kgs.
Item Number	31406	31815	31818

## COUNTERTOP COLD DELI SHOWCASES - DUAL DOORS

Model	RS-CN-0115-F	RS-CN-0155-F	RS-CN-0200-F
Temperature Range	2 - 8°C / 35.6 - 46.4°F		
Max Ambient Temp Rating	24°C / 75°F		
Capacity	115 L / 4 cu.ft.	155 L / 5.47 cu.ft.	200 L / 7 cu.ft.
Power	387W	453W	479W
Current	4.82A	4.58A	4.84A
Refrigerant	R134a, 185g	R134a, 270g	R134a, 300g
Number of Shelves	2		
Electrical	110V / 60Hz / 1		
Interior Dimensions	15.8" x 35.5" x 14.5" 400 x 902 x 368mm	15.8" x 47.3" x 14.5" 400 x 1200 x 368mm	15.8" x 59" x 14.5" 400 x 1499 x 368mm
Dimensions	21.3" x 35.5" x 31" 540 x 902 x 787mm	21.3" x 47.3" x 31" 540 x 1200 x 787mm	21.3" x 59" x 31" 540 x 1499 x 787mm
Weight	209.5 lbs. / 95 kgs.	253.5 lbs. / 115 kgs.	299.8 lbs. / 136 kgs.
Item Number	31865	31866	31867

# Installation

---

## TRANSPORTATION

1. In order to prevent the oil contained in the compressor from flowing into the cooling circuit, it is necessary to always carry, store and handle the unit in a vertical position and follow the instructions found on the packaging.
2. If the unit was accidentally or purposely placed in a non-vertical position during transport, before operating the unit, keep the unit in a vertical position for approximately 24 hours, to allow the oil to flow back into the compressor.

## UNPACKING

Remove the wooden case board and plastic covering. Make sure that the unit has not been damaged. Remove the plastic film from all the stainless steel panels if applicable.

**IMPORTANT: The packaging should be kept away from children as it is potentially dangerous. Dispose of the packaging according to the regulations from the local authorities.**

## POSITIONING

1. Never clean the unit with pressurized water jets.
2. Place the unit on a flat and stable surface.
3. Install the unit in a location where it can be overseen by trained personnel.
4. For good ventilation, keep a distance of 20 cm (7 inches) between unit and walls or other objects. Increase the distance if the objects are a heating source. When the dispenser is in place, press the brake on the wheels in order to keep it from moving.

## ASSEMBLY

1. Remove the bottom pallet from the unit.
2. Fix the shelves on the unit.

## ELECTRICAL CONNECTION

Before inserting the plug into the electrical socket, carefully read the following precautions:

1. Make sure that the unit is properly connected to an properly grounded outlet, in compliance with current safety standards.
2. Make sure that the voltage is in accordance with what is indicated on the rating label.
3. The current available is sufficient for the maximum required by the unit.
4. If necessary, use multiple outlets which are properly grounded, in compliance with current safety standards. If in doubt, only consult qualified technicians.

**THE REFRIGERATED SHOW CASE MUST BE CONNECTED TO AN ELECTRICAL SOCKET WITH A GROUND.**



Before using, the unit should be completely cleaned as it comes into contact with food.





1. Make sure that the main switch is in the (I) position, then plug in the unit.
2. Before starting the unit, ensure the sliding doors are properly closed.
3. Turn the main switch to the (I) position, the condensing unit will automatically start.
4. For lighting, press the lighting button. The lighting button is located on the thermostat.
5. If there is some condensation in front of the curved glass, please turn the switch to (I) position for defogging.
6. Allow the unit to reach proper temperature before loading with product.

## WORKING TEMPERATURE ADJUSTMENT

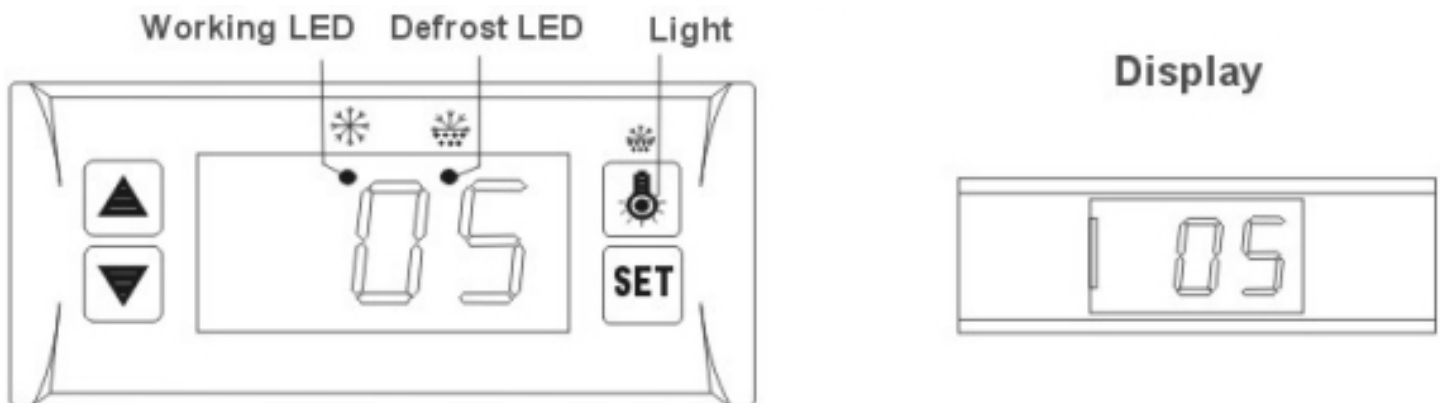
To reset the temperature inside the showcase, please follow as below:



**CAUTION: You are suggested not to reset the temperature controller frequently.**



1. Set Temperature
  - Press the SET button, the set temperature is displayed.
  - Press the  or  button to modify and store the display value, press the SET button to exit and display the cold room temperature.
  - If no button is pressed within 10 seconds, the cold room temperature will be displayed.
2. Illumination: Press  button, it lights. Press it again and it will stop.
3. Manual start/stop defrost: Press  and hold for 6 seconds to defrost or stop defrost.
4. Display Evaporation temperature: Press  button and hold for 6 seconds, the evaporation temperature is displayed. After 10 seconds, the cold room temperature will be displayed.
5. Working LED: During the course of refrigeration, the LED is on. When the cold room temperature is constant, the LED is off. During the delay start, the LED flashes.
6. Defrost LED: during defrosting, the LED is on. When it stops defrosting the LED is off. During the delay display of defrost, the LED flashes.
7. Parameter Setup:
  - Press the SET button and hold for 6 seconds to enter the parameter setup mode while E1 flashes.

# Operation

---

- Press SET again to select sequential from the 10 parameters: E1, E2, E3, E4, E4, E5, F1, F2, F3, F4.
- Press the  or  button, the different parameters will be displayed and can be modified and stored.
- If no more buttons are pressed within 10 seconds, the cold room temperature will be displayed.

Parameter	Function	Set Range
E1	Lower set point limit.	-45°C ~ Set temp.
E2	Higher set point limit.	Set temp. ~ 45°C.
E3	Temp. hysteresis.	1 - 10°C.
E4	Comp. start delay time.	0 - 10 mins.
E5	Offset on room temp.	-5 - 5°C.
E6	Offset on evap. temp.	-5 - 5°C.
F1	Max. defrost duration.	1 - 60 min.
F2	Defrost interval time.	0 - 24 Hr.
F3	Defrost termination temp.	0 - 20°C.
F4	Display during defrost.	0 = normal display. 1 = last value before defrost.

# Maintenance

---

## CLEANING

For health standards and good quality of beverages or foods, clean interiors of the unit as often as possible.

**CAUTION: Do not clean the unit by means of a water jet or pressurized washer.**

1. Before carrying out cleaning, turn the unit off and remove the power plug.
2. Do not use abrasive powders that might damage the interior parts of the showcase.
3. Use neutral soap and warm water to wash the interiors. Rinse carefully with water in order to remove any soap residues.
4. To maintain a high standard of working performance, leave the unit turned on during the night and day to avoid deposits.

**CAUTION: Do not use any damaging solvents (petrol, alcohol, etc.) for cleaning the unit. The unit may get damaged. Do not use and sharp objects for cleaning. The unit may be cleaned with a damp towel but should never directly come in contact with water. After cleaning the unit, make sure all parts are dried completely.**

## INSTRUCTIONS FOR DISPOSAL

When replacing your old unit with a new one, comply with the following information: Old units are not to be

# Maintenance

disposed of as regular waste. Valuable raw materials can be obtained by recycling old units.

### Render your old unit unusable:

1. Pull out the mains plug.
2. Cut off the mains cable and discard with the mains plug.

**Caution: Substances and gases in the thermal insulation must be disposed of professionally. Ensure that refrigeration tubing is not damaged prior to disposal. Please discard the unit according to the regulations of local law.**

# Troubleshooting

Symptom	Possible Reasons	Solution	Remark
No power input/power direction lamp does not light.	Broken fuse.	Replace.	As for authorized service department to check and repair.
	Poor connection of plug and socket.	Repair or replace the socket.	
	Failure in input control circuit.		
Compressor does not work.	Thermostat does not work.	Replace.	
	Thermostat is not on the working position.	Turning to the working position.	
	Poor contract of thermostat.	Insert the plug tightly.	
	Loose plug pins in the starter.	Insert the plug tightly.	
	Broken compressor.	Replace.	
	Broken starter or capacitor.	Repair or replace.	

# Troubleshooting

Compressor runs, but the temperature in the showcase is high.	Circulating temperature is too high.	Adjust the thermostat properly.	Ask for authorized service department to check and repair it.
	Too much dust and dirt on the condenser.	Clean it on time.	
	Frost on the evaporator is too thick.	Stop the machine to defrost. Set the temperature higher.	
	Thermostat is out of work.	Replace.	
Condenser fan does not run.	The capacitor of the fan is out of work.	Replace.	
	The ball-bearing of the fan motor lacks oil.	Fill oil.	
	The winding of the fan motor is damaged.	Replace.	
Compressor starts/stops frequently.	The winding of the compressor is short circuit.	Check with a multi meter, replace the compressor.	
	Poor contact of the socket.	Repair or replace.	
The fan of the evaporator does not work.	The fan motor is damaged.	Replace.	

**Warning: If the machine has any problems or has been damaged, do not try to repair or replace it by yourself. Please contact Omcan technical service at 1-800-465-0234.**

# Parts Breakdown

**Model RS-CN-0115-R** 31406

**Model RS-CN-0155-R** 31815

**Model RS-CN-0200-R** 31818

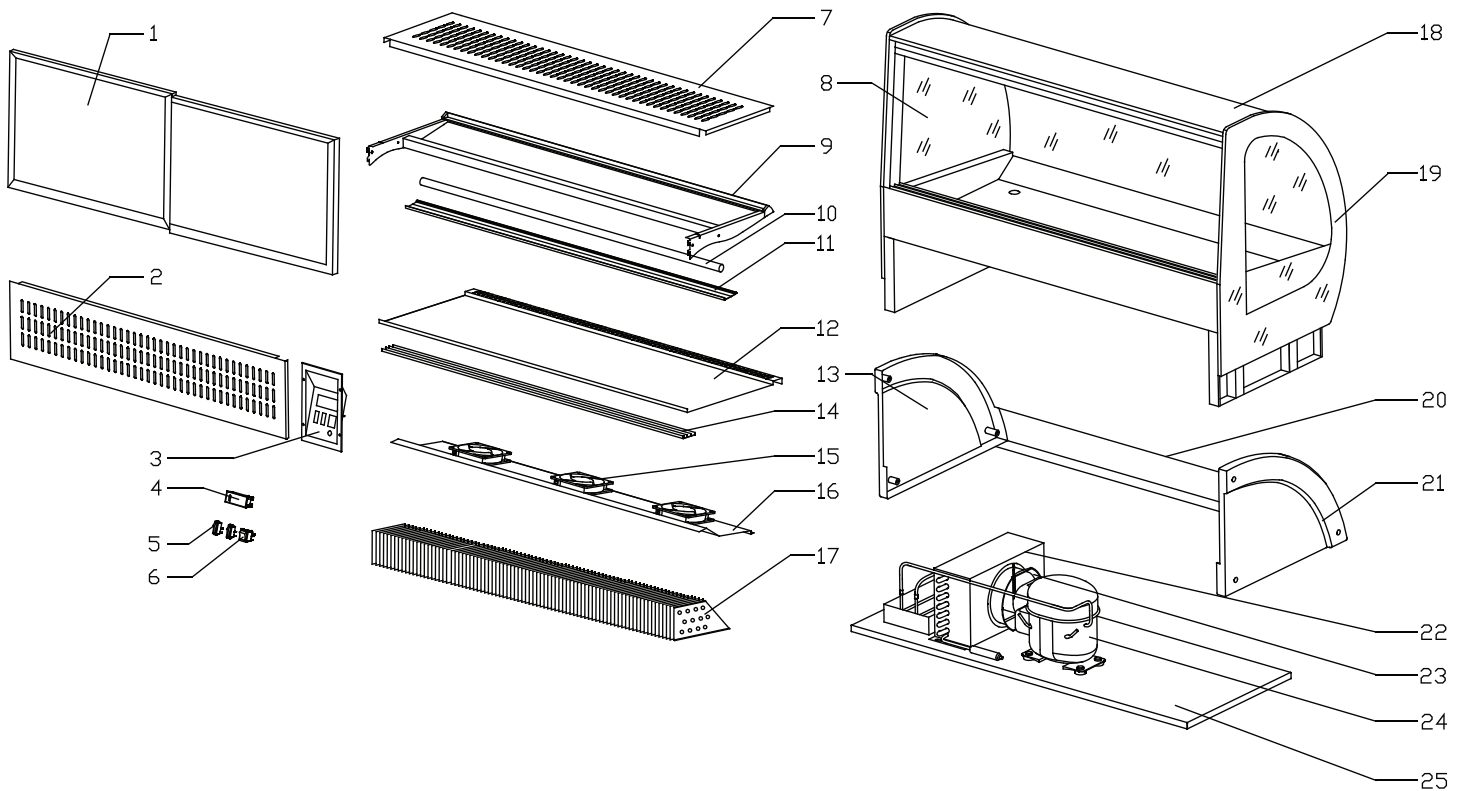

# Parts Breakdown

**Model RS-CN-0115-F** 31865

**Model RS-CN-0155-F** 31866

**Model RS-CN-0200-F** 31867

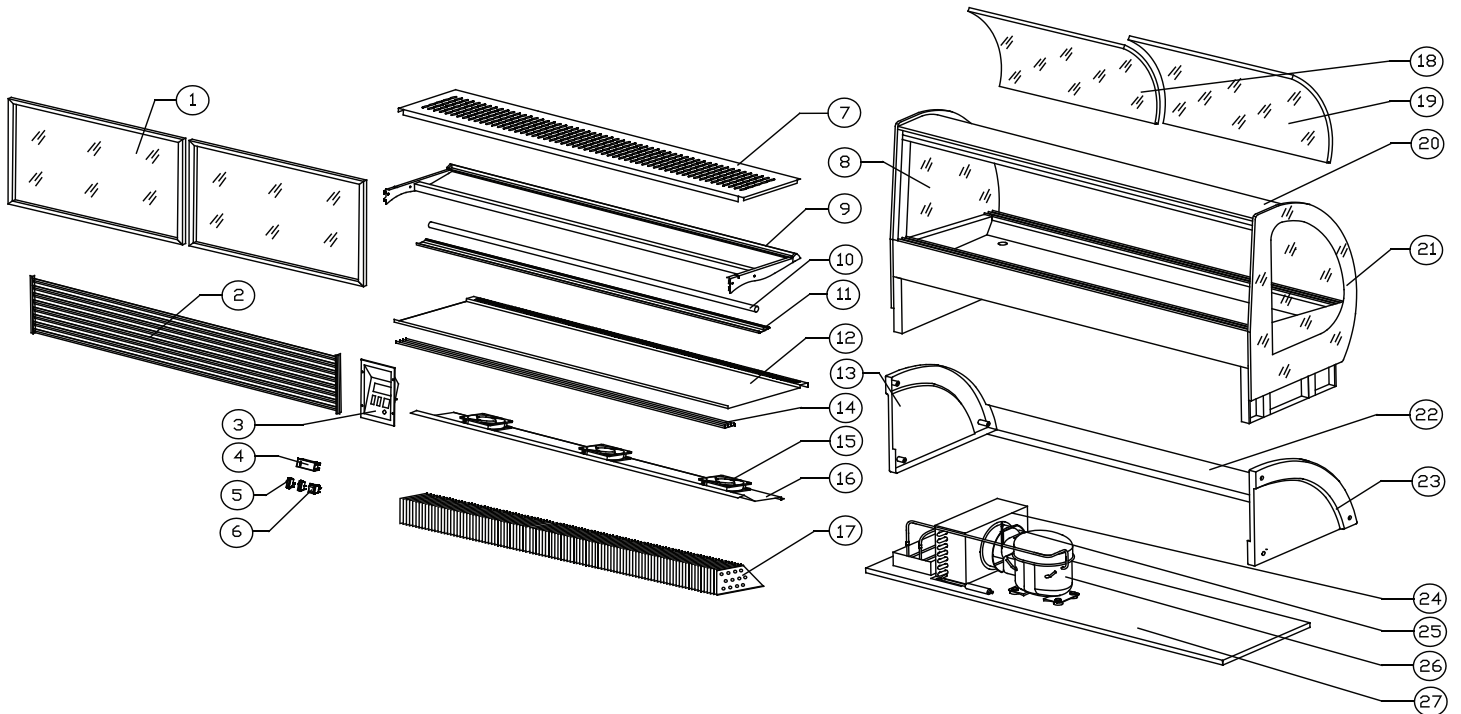

# Parts Breakdown

## Model RS-CN-0115-R 31406

Item No.	Description	Position	Item No.	Description	Position	Item No.	Description	Position
31679	Sliding Door for 31406	1	28385	Light for 31406	10	31697	Left Glass for 31406	19
31680	Back Air Grill for 31406	2	31689	Light Cover for 31406	11	74025	Decoration Front Panel for 31406	20
28378	Control Panel for 31406	3	31690	Bottom Stainless Steel Shelf for 31406	12	74026	Decoration Left Panel for 31406	21
31682	Digital Thermostat for 31406	4	74016	Decoration Right Panel for 31406	13	31700	Condenser for 31406	22
31683	Switch SC791 for 31406	5	74017	Rear Stainless Steel Air Grill for 31406	14	31701	Condenser Fan Motor for 31406	23
31684	Switch SC767 for 31406	6	31693	Evaporator Fan Motor for 31406	15	31669	Compressor for 31406	24
31685	Top Shelf for 31406	7	31694	Evaporator Cover for 31406	16	31703	Bottom Panel for 31406	25
31686	Right Side Glass for 31406	8	31695	Evaporator for 31406	17			
31687	Top Shelf Bracket for 31406	9	31696	Curved Glass for 31406	18			

## Model RS-CN-0155-R 31815

Item No.	Description	Position	Item No.	Description	Position	Item No.	Description	Position
73977	Sliding Door for 31815	1	28409	Light for 31815	10	74716	Left Glass for 31815	19
73978	Back Panel for 31815	2	73982	Light Cover for 31815	11	73988	Decoration Front Panel for 31815	20
74709	Controller Board for 31815	3	73983	Bottom Shelf Board for 31815	12	74717	Decoration Left Panel for 31815	21
74710	Digital Thermostat (PHEZSOP100) for 31815	4	74714	Decoration Right Panel for 31815	13	74718	Condenser for 31815	22
74711	Switch (SC791) for 31815	5	73984	Rear Stainless Steel Air Grill for 31815	14	74719	Condenser Fan Motor for 31815	23
74712	Switch SC767 for 31815	6	74715	Evaporator Fan Motor for 31815	15	73961	Compressor for 31815	24
73979	Top Shelf for 31815	7	73985	Evaporator Cover for 31815	16	73990	Bottom Panel for 31815	25
74713	Right Side Glass for 31815	8	73986	Evaporator for 31815	17			
73980	Top Shelf Bracket for 31815	9	73987	Curved Glass for 31815	18			

# Parts Breakdown

## Model RS-CN-0200-R 31818

Item No.	Description	Position	Item No.	Description	Position	Item No.	Description	Position
73991	Sliding Door for 31818	1	28427	Light for 31818	10	74727	Left Glass for 31818	19
73992	Back Panel for 31818	2	73996	Light Cover for 31818	11	74002	Decoration Front Panel for 31818	20
74720	Controller Board for 31818	3	73997	Bottom Shelf Board for 31818	12	74728	Decoration Left Panel for 31818	21
74721	Digital Thermostat (PHEZSOP100) for 31818	4	74725	Decoration Right Panel for 31818	13	74729	Condenser for 31818	22
74722	Switch (SC791) for 31818	5	73998	Rear Stainless Steel Air Grill for 31818	14	74730	Condenser Fan Motor for 31818	23
74723	Switch SC767 for 31818	6	74726	Evaporator Fan Motor for 31818	15	74731	Compressor for 31818	24
73993	Top Shelf for 31818	7	73999	Evaporator Cover for 31818	16	74003	Bottom Panel for 31818	25
74724	Right Side Glass for 31818	8	74000	Evaporator for 31818	17			
73994	Top Shelf Bracket for 31818	9	74001	Curved Glass for 31818	18			

## Model RS-CN-0115-F 31865

Item No.	Description	Position	Item No.	Description	Position	Item No.	Description	Position
74004	Sliding Door for 31865	1	28385	Light for 31865	10	74022	Front Sliding Door (Exterior) for 31865	19
74005	Back Panel for 31865	2	31689	Light Cover for 31865	11	74023	Top Glass for 31865	20
31677	Controller Board for 31865	3	74015	Bottom Shelf Board for 31865	12	74024	Left Glass for 31865	21
74007	Controller JC-602 for 31865	4	74016	Decoration Right Panel for 31865	13	74025	Decoration Front Panel for 31865	22
28023	Small Switch for 31865	5	74017	Rear Stainless Steel Air Grill for 31865	14	74026	Decoration Left Panel for 31865	23
28022	Main Switch for 31865	6	74018	Evaporator Fan Motor for 31865	15	31700	Condenser for 31865	24
74010	Shelf for 31865	7	74019	Evaporator Rack for 31865	16	74028	Condenser Fan Motor for 31865	25
74011	Right Glass for 31865	8	74020	Evaporator for 31865	17	74029	Compressor for 31865	26
74012	Bracket for 31865	9	74021	Front Sliding Door (Inner) for 31865	18	74030	Bottom Panel for 31865	27



# Parts Breakdown

## Model RS-CN-0155-F 31866

Item No.	Description	Position	Item No.	Description	Position	Item No.	Description	Position
74031	Sliding Door for 31866	1	28409	Light for 31866	10	74042	Front Sliding Door (Exterior) for 31866	19
74032	Back Panel for 31866	2	73982	Light Cover for 31866	11	74043	Top Glass for 31866	20
31677	Controller Board for 31866	3	74037	Bottom Shelf Board for 31866	12	74024	Left Glass for 31866	21
74007	Controller JC-602 for 31866	4	74016	Decoration Right Panel for 31866	13	73988	Decoration Front Panel for 31866	22
28023	Small Switch for 31866	5	73984	Rear Stainless Steel Air Grill for 31866	14	74026	Decoration Left Panel for 31866	23
28022	Main Switch for 31866	6	74018	Evaporator Fan Motor for 31866	15	31700	Condenser for 31866	24
74033	Shelf for 31866	7	74039	Evaporator Rack for 31866	16	74028	Condenser Fan Motor for 31866	25
74011	Right Glass for 31866	8	74040	Evaporator for 31866	17	74045	Compressor for 31866	26
74034	Bracket for 31866	9	74041	Front Sliding Door (Inner) for 31866	18	74046	Bottom Panel for 31866	27

## Model RS-CN-0200-F 31867

Item No.	Description	Position	Item No.	Description	Position	Item No.	Description	Position
74047	Sliding Door for 31867	1	28427	Light for 31867	10	74058	Front Sliding Door (Exterior) for 31867	19
74048	Back Panel for 31867	2	73996	Light Cover for 31867	11	74059	Top Glass for 31867	20
31677	Controller Board for 31867	3	74053	Bottom Shelf Board for 31867	12	74024	Left Glass for 31867	21
74007	Controller JC-602 for 31867	4	74016	Decoration Right Panel for 31867	13	74002	Decoration Front Panel for 31867	22
28023	Small Switch for 31867	5	73998	Rear Stainless Steel Air Grill for 31867	14	74026	Decoration Left Panel for 31867	23
28022	Main Switch for 31867	6	74018	Evaporator Fan Motor for 31867	15	31700	Condenser for 31867	24
74049	Shelf for 31867	7	74055	Evaporator Rack for 31867	16	74028	Condenser Fan Motor for 31867	25
74011	Right Glass for 31867	8	74056	Evaporator for 31867	17	74045	Compressor for 31867	26
74050	Bracket for 31867	9	74057	Front Sliding Door (Inner) for 31867	18	74062	Bottom Panel for 31867	27

# Electrical Schematics

**Model RS-CN-0115-R** 31406

**Model RS-CN-0155-R** 31815

**Model RS-CN-0200-R** 31818

**Model RS-CN-0115-F** 31865

**Model RS-CN-0155-F** 31866

**Model RS-CN-0200-F** 31867

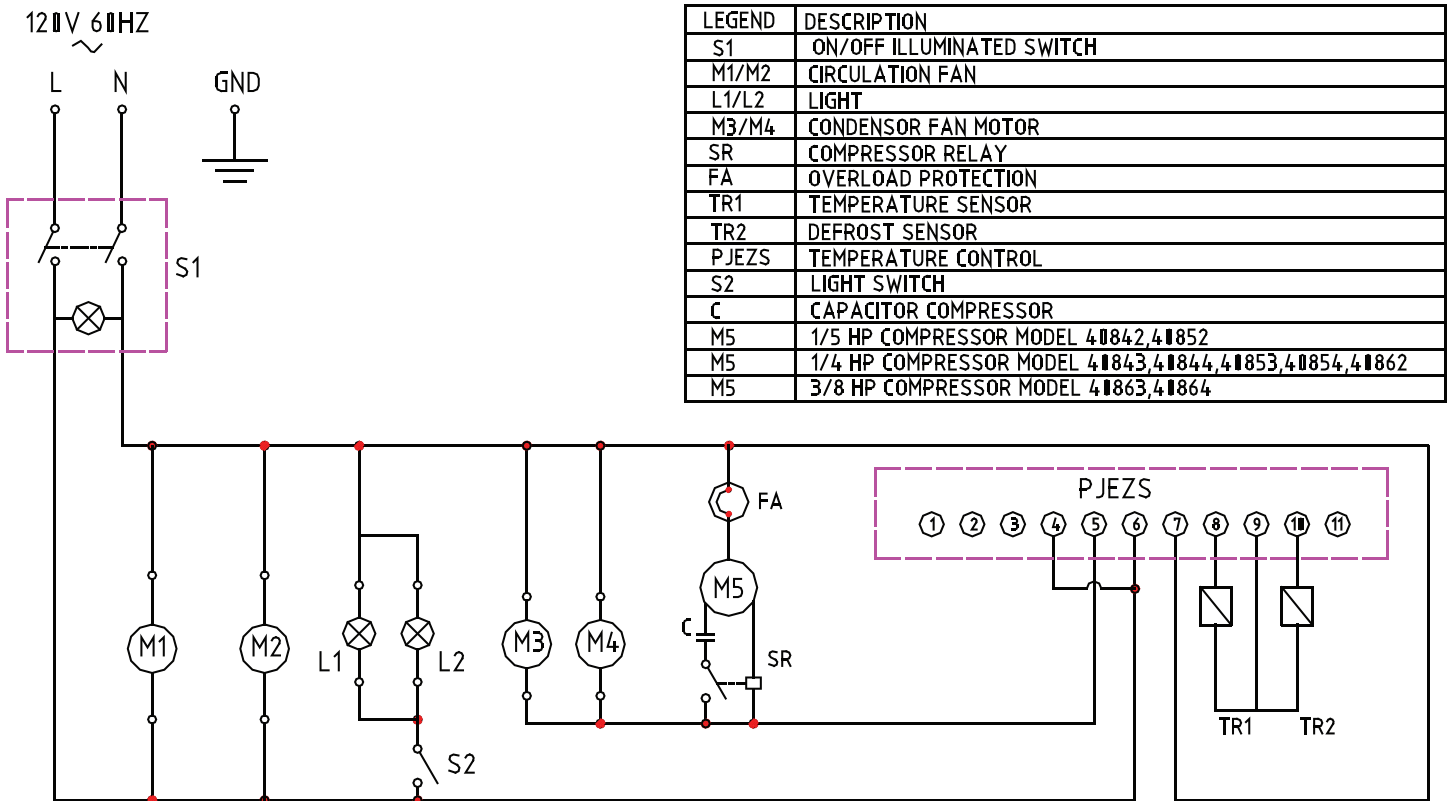



# Warranty Registration

Thank you for purchasing an Omcan product. To register your warranty for this product, complete the information below, tear off the card at the perforation and then send to the address specified below. You can also register online by visiting:

Merci d'avoir acheté un produit Omcan. Pour enregistrer votre garantie pour ce produit, complétez les informations ci-dessous, détachez la carte au niveau de la perforation, puis l'envoyer à l'adresse spécifiée ci-dessous. Vous pouvez également vous inscrire en ligne en visitant:

Gracias por comprar un producto Omcan usted. Para registrar su garantía para este producto, complete la información a continuación, cortar la tarjeta en la perforación y luego enviarlo a la dirección indicada a continuación. También puede registrarse en línea en:

<https://omcan.com/warranty-registration/>

For mailing in Canada

Pour postale au Canada

Por correo en Canadá

**OMCAN**

PRODUCT WARRANTY REGISTRATION

3115 Pepper Mill Court,

Mississauga, Ontario

Canada, L5L 4X5

For mailing in the US

Pour diffusion aux États-Unis

Por correo en los EE.UU.

**OMCAN**

PRODUCT WARRANTY REGISTRATION

4450 Witmer Industrial Estates, Unit 4,

Niagara Falls, New York

USA, 14305

*or email to: [service@omcan.com](mailto:service@omcan.com)*



Purchaser's Information

Name: \_\_\_\_\_

Address: \_\_\_\_\_

City: \_\_\_\_\_ Province or State: \_\_\_\_\_ Postal or Zip: \_\_\_\_\_

Country: \_\_\_\_\_

Dealer from which Purchased: \_\_\_\_\_

Dealer City: \_\_\_\_\_ Dealer Province or State: \_\_\_\_\_

Invoice: \_\_\_\_\_

Model Name: \_\_\_\_\_ Model Number: \_\_\_\_\_

Machine Description: \_\_\_\_\_

Date of Purchase (MM/DD/YYYY): \_\_\_\_\_

Would you like to extend the warranty?  Yes  No

Company Name: \_\_\_\_\_

Telephone: \_\_\_\_\_

Email Address: \_\_\_\_\_

Type of Company:

Restaurant  Bakery  Deli

Butcher  Supermarket  Caterer

Institution (*specify*): \_\_\_\_\_

Other (*specify*): \_\_\_\_\_

Serial Number: \_\_\_\_\_

Date of Installation (MM/DD/YYYY): \_\_\_\_\_

**Thank you for choosing Omcan | Merci d'avoir choisi Omcan | Gracias por elegir Omcan**



Since 1951 Omcan has grown to become a leading distributor of equipment and supplies to the North American food service industry. Our success over these many years can be attributed to our commitment to strengthen and develop new and existing relationships with our valued customers and manufacturers. Today with partners in North America, Europe, Asia and South America, we continually work to improve and grow the company. We strive to offer customers exceptional value through our qualified local sales and service representatives who provide convenient access to over 6,500 globally sourced products.

---

Depuis 1951 Omcan a grandi pour devenir un des “leaders” de la distribution des équipements et matériel pour l’industrie des services alimentaires en Amérique du Nord. Notre succès au cours de ces nombreuses années peut être attribué à notre engagement à renforcer et à développer de nouvelles et existantes relations avec nos clients et les fabricants de valeur. Aujourd’hui avec des partenaires en Amérique du Nord, Europe, Asie et Amérique du Sud, nous travaillons continuellement à améliorer et développer l’entreprise. Nous nous efforçons d’offrir à nos clients une valeur exceptionnelle grâce à nos ventes locales qualifiées et des représentants de service qui offrent un accès facile à plus de 6500 produits provenant du monde entier.

---

Desde 1951 Omcan ha crecido hasta convertirse en un líder en la distribución de equipos y suministros de alimentos en América del Norte industria de servicios. Nuestro éxito en estos años se puede atribuir a nuestro compromiso de fortalecer y desarrollar nuevas relaciones existentes con nuestros valiosos clientes y fabricantes. Hoy con socios de América del Norte, Europa, Asia y América del Sur, que trabajan continuamente para mejorar y crecer la empresa. Nos esforzamos por ofrecer a nuestros clientes valor excepcional a través de nuestro local de ventas y representantes de los servicios que proporcionan un fácil acceso a más de 6,500 productos con origen a nivel mundial.

