



Project _____
 AIA # _____ SIS # _____
 Item # _____ Quantity _____ C.S.I. Section 114000



HWS-4-C Hand-Wrap Station



**HTsP/HTiP
Hand-Wrap System
with Color Touch Screen**



**Access Scale Hand-Wrap System
with Color Touch Screen**



SPECIFIER STATEMENT

The Hobart hand wrapping system is designed for the operator to manually weight and wrap a package and then place the wrapper package on the heated sealing pad. A separate, remote printer will compute the price and print the label for the operator to manually apply to the package.

MODEL

- HWS-4-C** Hand-wrap station

NOTE: For a complete hand-wrap system: Console/printer, weigher, platter, and post assembly kit must be ordered separately. Refer to System Configuration Chart.

STANDARD FEATURES

- + Flexible set-up
- + Easy to load film
- + 20" film capacity
- + Fingertip film selection
- + Low temperature film cut-off system
- + Angled sealing hot plate covered with non-stick removable cover
- + Stainless steel element
- + Heavy-duty 300 series stainless steel stand assembly
- + 2 stainless steel side shelves
- + Open scale area
- + Operates in all ambient temperatures
- + 12 hour timer for hot plate and cut-off rod to save electric
- + Convenient outlet provided for scale/printer power

ACCESSORIES (Available at extra cost)

- HWS-WRAPAD – Hand-wrap station package rest
- LIBRARY-SUPPRT – Library support for PLU look up (Requires POST-LGSP assembly kit for mounting)
- POST-LGSP – Post assembly kit for library support
- HRT-LD136 – Single label dispenser, 36"
- HRT-LD236 – Double label dispenser, 36"
- HRT-LABKIT – Kit of 49 additional disks for label roll separation (each dispenser comes with 20)

HWS-4-C HAND-WRAP STATION

Approved by _____ Date _____ Approved by _____ Date _____



SPECIFICATIONS

Construction: Heavy-duty stainless steel frame.
36¹/₄" H x 27"W x 27"D. Shelf 12⁵/₈"W x 28"D.

Hot Plate: 15" W x 6"D.

Film Holders: Two roll film selector. Capacity 10" diameter x 20" maximum.

Electrical: 120 Volts, 60 Hertz, single phase, 8.5 Amps.

Shipping Weight: HWS – approximately 90 lbs.;
POST-LGSP – 4 lbs.; HWS-WRAPAD – 8 lbs.

HWS-4-C ACCESS SYSTEM CONFIGURATION COMPONENTS

HTsP/HTiP Hand Wrap System Description	Hand Wrap System Model	Control Panel	Printer	Weigher	Weigher Capacity	Platter	Post Assembly Kit
Access Hand-Wrap System (50 lb.)	HWS-4-C	EPCP-5s	EPP-3	EPSA-1	50 x 0.01 lb.	ACCESS-LGPLAT	ACCESS-HWSKIT
Access Hand-Wrap System (30 lb.)	HWS-4-C	EPCP-5s	EPP-3	EPSA-2	30 x 0.01 lb.	ACCESS-LGPLAT	ACCESS-HWSKIT

DETAILS AND DIMENSIONS – ACCESS HAND-WRAP SYSTEM

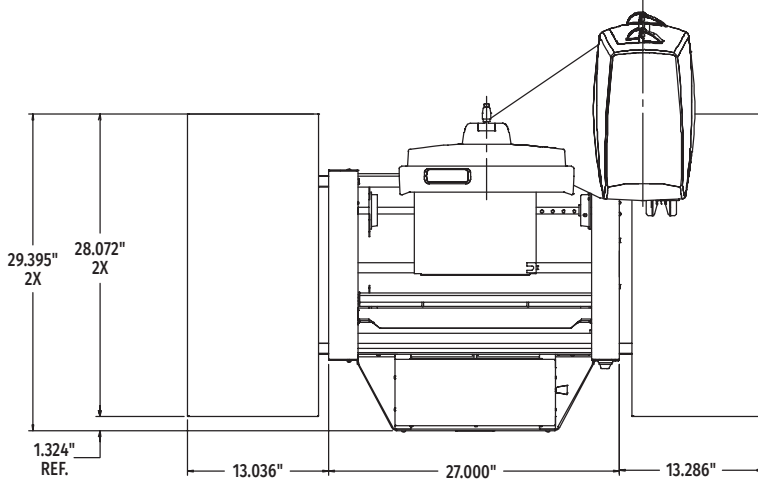

NOTE: For ACCESS Hand Wrap System: Control Panel, Weigher, Printer, Platter, and Post Assembly must be ordered separately.

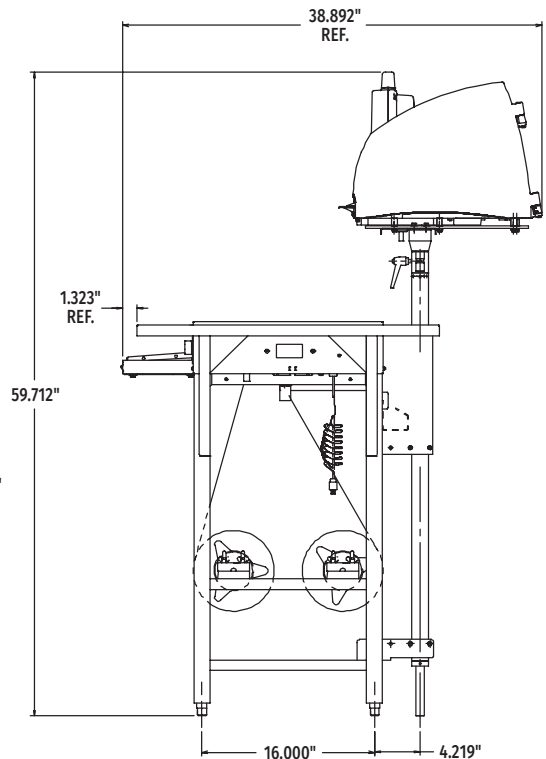
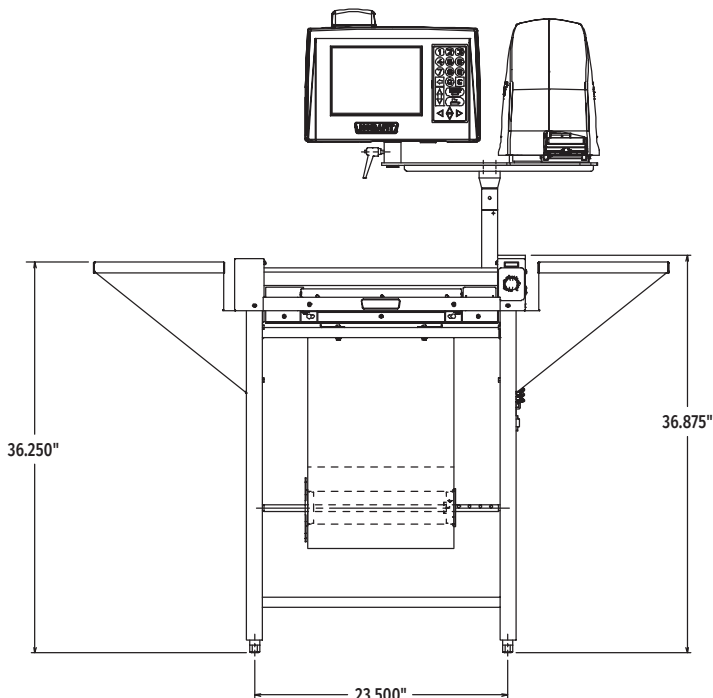



HWS-4-C HT SYSTEM CONFIGURATION COMPONENTS

HTsP/HTiP Hand Wrap System Description	Hand Wrap System Model	Control Panel	Printer	Weigher	Weigher Capacity	Platter	Post Assembly Kit
HT Hand-Wrap System (30 lb.)	HWS-4-C	HTsP-LS or HTiP-LH		SASCALE-2	30 x 0.01 lb.	ACCESS-LGPLAT	HT-HWSKIT

DETAILS AND DIMENSIONS – HT HAND-WRAP SYSTEM

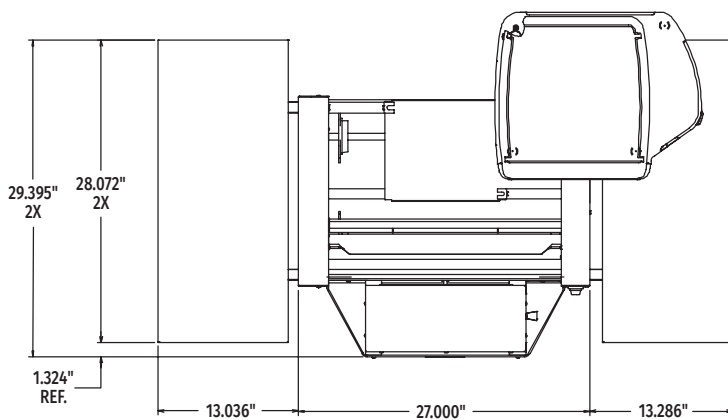

NOTE: For HT Hand Wrap System: Control Panel, Weigher, Printer, Platter, and Post Assembly must be ordered separately.

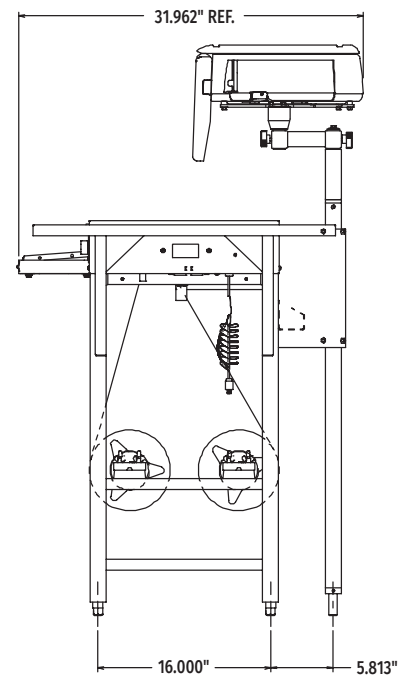
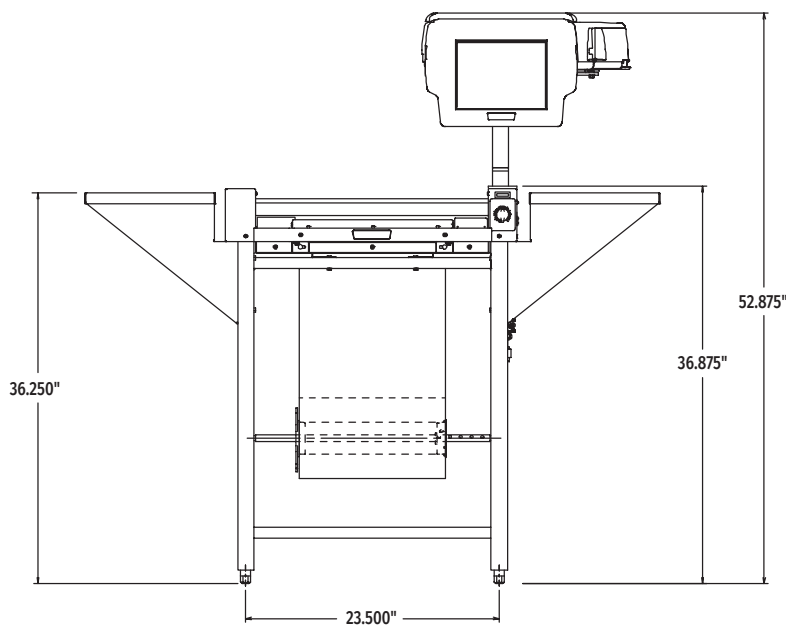

As continued product improvement is a policy of Hobart, specifications are subject to change without notice.