

Combi oven

C4eT 20.20 EB-N

Convotherm 4 deluxe easyTouch

- 20.20
- 20 slide rails
- Electric
- Boiler
- Right-hinged door



Key Features

- Advanced Closed System+ (ACS+) cooking methods: Steam, combi-steam, hot air
- Advanced Closed System+ (ACS+) with extra functions:
 - Crisp&Tasty - 5 moisture-removal settings
 - BakePro - 5 levels of traditional baking
 - HumidityPro - 5 humidity settings
 - Controllable fan - 5 speed settings
- easyTouch 10" TFT high-resolution glass touch display (capacitive)
- ConvoClean+ fully automatic cleaning system with eco, regular and express modes - with optional single-dose dispensing
- HygieniCare
- WiFi and Ethernet port (LAN)
- TriColor indicator ring - indicates the current operating status
- Steam generated by high-performance boiler outside the cooking chamber
- Right-hinged door

Standard features

- Cooking methods:
 - Steam (86-266°F) with guaranteed steam saturation
 - Combi-steam (86-482°F) with automatic humidity adjustment
 - Hot air (86-482°F) with optimized heat transfer
- easyTouch user interface controls:
 - 10" TFT high-resolution glass touch display (capacitive)
 - Smooth-action, quick-reacting scrolling function
- Climate Management
 - Advanced Closed System+ (ACS+), HumidityPro, Crisp&Tasty
- Quality Management
 - Airflow Management, BakePro, multi-point core temperature probe, preheat and cool-down function
- Production Management
 - Automatic cooking with Press&Go with up to 399 profiles
 - Integrated cookbook with 7 different categories
 - TrayTimer - load management for different products simultaneously
 - TrayView - load management for automatic cooking of different products using Press&Go
 - Favorites management
 - HACCP data storage
 - USB port
 - ecoCooking - energy saving function
 - LT cooking (low-temperature cooking) / Delta-T cooking
 - Cook&Hold - cooking and keeping food warm in a single process
 - Auto Start
 - Rethermalization+: versatile multi-mode rethermalization function

Standard features

- Cleaning Management:
 - ConvoClean+: Fully automatic cleaning system
 - Quick access to individually created and stored cleaning profiles
 - Cleaning Scheduler
- HygieniCare:
 - Hygienic Steam Function
 - Hygienic handles
 - SteamDisinfect
- Design:
 - Right-hinged unit door with safety lock, sure-shut function, and venting position
 - Steam generated by boiler
 - Adjustable feet with adjustment range between 4 inches and 5 inches
 - Multi-point core temperature probe
 - Integrated recoil hand shower



Convotherm 4 deluxe easyTouch

- 20.20
- 20 slide rails
- Electric
- Boiler
- Right-hinged door



Key Features

- Advanced Closed System+ (ACS+) cooking methods: Steam, combi-steam, hot air
- Advanced Closed System+ (ACS+) with extra functions:
 - Crisp&Tasty - 5 moisture-removal settings
 - BakePro - 5 levels of traditional baking
 - HumidityPro - 5 humidity settings
 - Controllable fan - 5 speed settings
- easyTouch 10" TFT high-resolution glass touch display (capacitive)
- ConvoClean+ fully automatic cleaning system with eco, regular and express modes - with optional single-dose dispensing
- HygieneCare
- WiFi and Ethernet port (LAN)
- TriColor indicator ring - indicates the current operating status
- Steam generated by high-performance boiler outside the cooking chamber
- Right-hinged door

Options

- Disappearing door - more space and added safety (see page 3)
- Quality Management:
 - ConvoSmoke - built in food-smoking (HotSmoke)
 - ConvoGrill with grease management function
- Steam and vapor removal - built-in condenser
- Corrections package
- Available in various voltages
- Sous-vide probe, external connection
- Core temperature probe, external connection (internal core probe standard)

Accessories

- kitchenconnect® (WiFi/LAN), network solution from Welbilt for updating and monitoring appliances from anywhere
- Signal Tower
- Banquet system (optionally as a package or individually): Plate loading trolley, loading trolley, thermal cover

Accessories and services by partners

- Cleaning chemicals for the fully automatic ConvoClean+ cleaning system (multiple-dose and single-dose dispensing)
- Water filtration and reverse osmosis systems and replacement filters
- Installation services available - details in AutoQuotes - availability may vary by region
- Cooking, baking, and roasting cookware

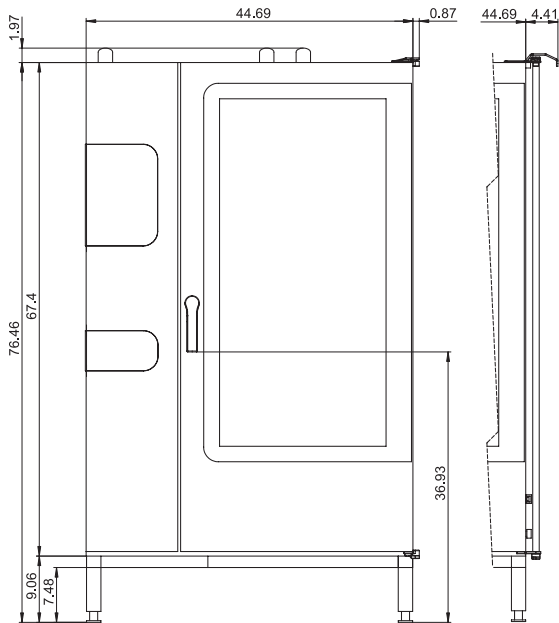
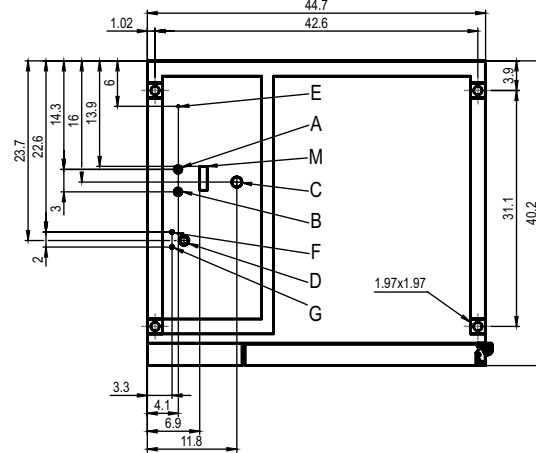
Front view

Connection points, bottom of unit

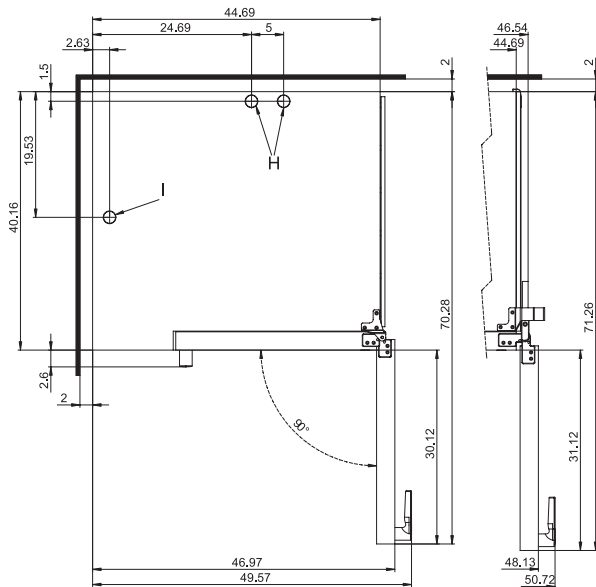
- A Water connection (for boiler)
- B Water connection (for cleaning, recoil hand shower)
- C Drain connection (2" I. D.)
- D Electrical connection
- E Equipotential bonding
- F Rinse-aid connection
- G Cleaning-agent connection
- H Air vent (2" I. D.)
- I Dry air intake (2" I. D.)
- M Safety overflow 3.2" x 1"
Ethernet connection RJ45

View from above with wall clearances

(disappearing door optional)

Dimensions and weights

| Dimensions including packaging | |
|---|-----------------------|
| Width x height x depth | 56.3" x 85.0" x 46.9" |
| Weight | |
| Net weight without options* / accessories | 794 lbs |
| Packaging weight | 106 lbs |
| Safety clearances** | |
| Rear | 2" |
| Right (right-hinged door) | 2" |
| Right (disappearing door pushed back) | 6" |
| Left (see installation requirements) | 2" |
| Top*** | 20" |

* Max. weight of options: 33 lbs.

** Required for the unit to work properly.

*** Depends on the type of exhaust system and the ceiling's characteristics.

Installation requirements

| | |
|--|----------------|
| Max. absolute appliance inclination during operation* | max. 2° (3.5%) |
| Clearance from heat sources | min. 20" |
| Recommended clearance for servicing on the left side of the unit | min. 20" |

* Adjustable appliance feet as standard.

Loading capacity

Max. number of food containers

[Unit has 20 slide rails; rail spacing 2.68" max.]

| | |
|---|----|
| Steam table pans (12"x20"x1") | 40 |
| Steam table pans (12"x20"x2.5") | 40 |
| Wire shelves, full size (20"x26") | 20 |
| Sheet pans, full size (18"x26")* | 20 |
| Sheet pans, half size (13"x18")* | 40 |
| Frying baskets, half size (12"x20") | 40 |
| Plates (optional plate banquet trolley) | 98 |

Max. loading weight

| | |
|-----------------|---------|
| Per combi oven | 397 lbs |
| Per shelf level | 33 lbs |

* Wire shelves required.

Electrical supply

208V 3PH 60Hz / 240V 3PH 60Hz *

| | |
|-----------------------------|-----------------|
| Rated power consumption | 54.4 / 72.3 kW |
| Rated current | 151.1 / 174.1 A |
| Power supply wire gauge | 2/0 3/0 AWG |
| Conductor insulation rating | 194°F / 90 °C |

440V 3PH 60Hz / 480V 3PH 60Hz *

| | |
|-----------------------------|----------------|
| Rated power consumption | 56.3 / 66.8 kW |
| Rated current | 73.9 / 80.5 A |
| Power supply wire gauge | 4/3 AWG |
| Conductor insulation rating | 194°F / 90 °C |

* Prepared for connection to an energy optimizing system.

Water connection

| | |
|---------------------|--|
| Water supply | |
| Water supply | Two hoses 1/2" inner diameter with one side 3/4" GHT-F to 3/4" BST The unit is designed for a permanent hookup to the water supply that uses a connecting hose with a minimum diameter of 1/2". |
| Flow pressure | 22 - 87 psi / 1.5 - 6 bar |
| Drain | |
| Drain version | Naturally ventilated pipe to open pan or drain/channel |
| Type | 2" inside diameter (comes elbow-shaped as standard) |
| Slope for drainpipe | min. 3.5% (2°) |

Water quality

Water connection A* for boiler,
Water connection B* for cleaning, recoil hand shower

| | |
|---|---|
| General requirements | Drinking water, typically untreated water |
| TDS | 70 - 360 ppm |
| Hardness** | 70 - 360 ppm (4 - 21 gpg) |
| pH value | 6.5 - 8.5 |
| Cl ⁻ (chloride) | max. 60 ppm |
| Cl ₂ (free chlorine) | max. 0.2 ppm |
| SO ₄ ²⁻ (sulfate) | max. 150 ppm |
| Fe (iron) | max. 0.1 ppm |
| SiO ₂ (silica) | max. 13 ppm |
| NH ₂ Cl (monochloramine) | max. 0.2 ppm |
| Temperature | max. 104°F / max. 40°C |

* Please refer to the connection points diagram, p. 2.

** Even if the limits are adhered to, deposits of minerals that do not cause hardness may occur in certain cases. Any measures used to prevent this must be clarified with Technical Support.

NOTICE: The owner/operator/purchaser must ensure that the water quality requirements are met. Otherwise the unit warranty is void.

Water consumption

| | |
|-----------------------------------|---------|
| Water connections A, B | |
| Average consumption for cooking** | 3.5 gph |
| Required flow rate | 4.0 gpm |

** Incl. water required for cooling the wastewater.

NOTICE: See connection positions diagram, p. 2.

Emissions

| | |
|-------------------|-------------------|
| Heat loss | |
| Latent | 10500 BTU/h |
| Sensible | 13400 BTU/h |
| Drain temperature | max. 140°F / 60°C |
| Decibel rating | max. 70 dBA |

