



RFP0320A Flake Ice Machines

Models

- RFP0320A



Model RFP0320A
Flake Ice Machine
on D-420 Bin

Standard Features

- Up to 370 lbs. (168 kgs) daily flake ice production.
- High load maintenance free bearing for enhanced reliability.
- R290 Refrigerant is environmentally friendly with less ozone depletion compared to R404
- Flake ice is perfect for food display, salad bar, and cold therapy/healthcare
- Ice form around object without bruising and hold object in place without tipping/spilling
- Heavy duty stainless steel cabinet resists corrosion



Specifications

Condenser Heat of Rejection (BTU per hour):

7,511 (average)

Compressor:

Nominal rating: 3/4 HP

Refrigerant:

R290

Operating Limits:

- Ambient Temperature Range: 50°-110°F (10°-43°C)
- Water Temperature Range: 37°-90°F (3°-32°C)
- Water Pressure Ice Maker Water In: Min. 14 psi (96.5 kPa) Max. 80 psi (551.1 kPa)

Ice Machine Electric

115/60/1 standard. (230/50/1 also available.)

Minimum circuit ampacity:

7.5 amps.

Maximum fuse size:

15 amps.

HACR-type circuit breakers can be used in place of fuses.

Standard Features

Flake ice is small hard bits of ice ideally suited for presentation applications.



Ice shown actual size



UL STD 563 CAN/CSA-C22.2 No. 120
SANITATION NSF/ANSI STD 12



RFP0320A Flake Ice Machine



RFP0320A Flake Ice Machine

RFP0320 on D-420

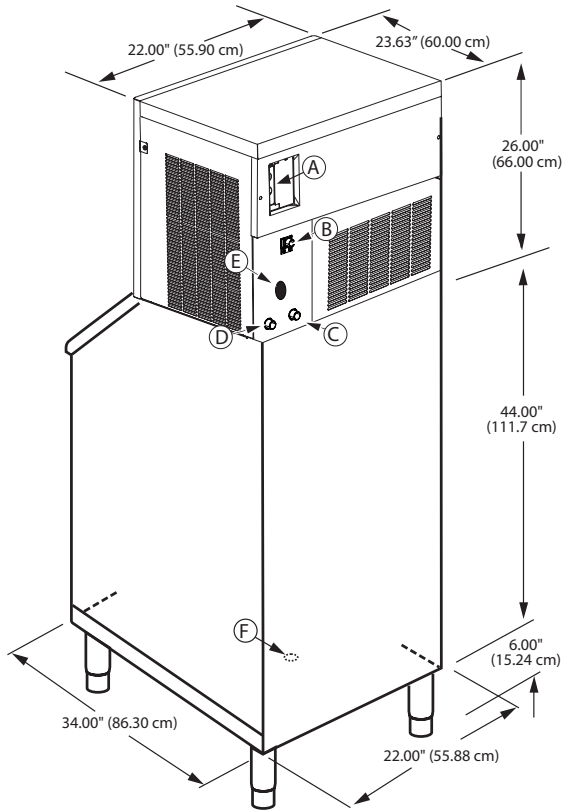

Installation Note -
Minimum installation clearance:
Top/sides: 8" (20.32 cm),
Back: 5" (12.70 cm).

- Ⓐ Electrical Entrance (2) Options
- Ⓑ 3/8" F.P.T. Condenser Inlet (water-cooled only)
- Ⓒ 1/2" M.P.T. Condenser Drain (water-cooled only)
- Ⓓ 1/2" M.P.T. Ice Making Water Drain
- Ⓔ 3/8" F.P.T. Ice Making Water Inlet
- Ⓕ 3/4" Bin Drain

Ice Machine Electric



	RFP0320 on D-420
Height	76.00"
	193.00 cm
Width	22.00"
	55.90 cm
Depth	34.00"
	86.36 cm
Bin Storage	310 lbs.
	140.7 kgs

Height includes adjustable bin legs 6.00" to 7.00", (15.24 to 17.78 cm) set at 6.00" (15.24 cm).

Ice Machine Accessories

K00472 30" D Style Bin Adapter

Air Flow Overhead View

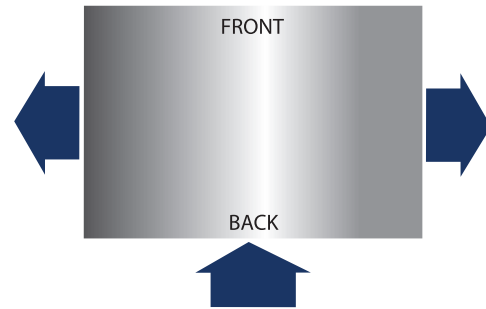

Air-Cooled Ice Machine	Model	Ice Shape	Ice Production 24 Hours		Power kWh/100 lbs @ 90°Air/70°F	Potable Water Usage (100 lbs./45.4 kgs of Ice)
			70° Air/50°F Water 21° Air/10° C Water	90° Air/70°F Water 32° Air/21° C Water		
			RFP0320A	Flake		

★ ENERGY STAR® 3.0

Manitowoc Ice reserves the right to make changes to the design or specifications without prior notice.