

Protected By: U.S. Patent No. 11,129,484

**Quickly Converts From Cafeteria Style
To Self Serve Style**

Item #: _____ Qty #: _____
 Model #: _____
 Project #: _____



DSG-12G-84 Glass Positioned For Self-Serve Style
(Shown with Optional SG-1 Surface Mounting Brackets)

DSG-12G-84 Glass Positioned For Cafeteria Style
(Shown with Optional SG-1 Surface Mounting Brackets)

FEATURES:

- Bottom front glass locks in place at 3 fixed positions
- Entire glass front rotates for easy cleaning
- Stainless steel 1" diameter Posts
- Includes Two 18" Wide Glass Side Panels
- 1/4" Thick Heat-Tempered Glass Side Panels
- 3/8" Thick Heat-Tempered Glass Fronts
- 3/8" Thick Heat-Tempered Glass Top

CONSTRUCTION:

All TIG welded
 Exposed stainless steel surfaces polished to a satin finish

MATERIAL:

1/4" Thick Heat-Tempered Side Glass
 3/8" Thick Heat-Tempered Glass Fronts and Top
 1" Posts - Stainless Steel
 Chamber Lock™ Sleek Shield Assemblies - Anodized Aluminum.
 Finish - Aluminum components are anodized to a satin finish.
 Stainless components polished.



Bottom Glass Flips All The Way Up
To Become A Self-Serve Unit

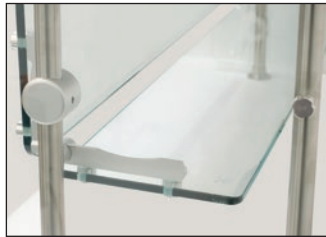

Bottom Glass Can be Used As a Shelf

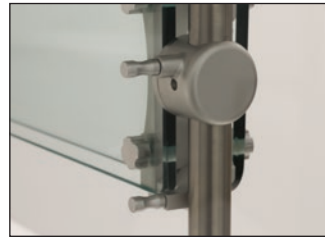

Easy To Use Mechanism
For Changing Front Glass Positions

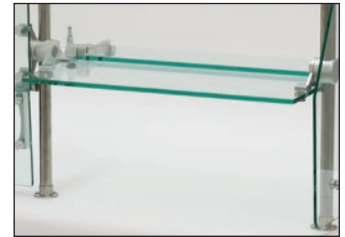

Entire Glass Shield Rotates
For Easy Cleaning

L	12" WIDE	Approx. Wt.	15" WIDE	Approx. Wt.	18" WIDE	Approx. Wt.	Approx. Cubes
36"	DSG-12G-36	139 lbs.	DSG-15G-36	143 lbs.	DSG-18G-36	147 lbs.	18
48"	DSG-12G-48	179 lbs.	DSG-15G-48	182 lbs.	DSG-18G-48	187 lbs.	23
60"	DSG-12G-60	228 lbs.	DSG-15G-60	235 lbs.	DSG-18G-60	242 lbs.	29
72"	DSG-12G-72	279 lbs.	DSG-15G-72	266 lbs.	DSG-18G-72	275 lbs.	34
84"	DSG-12G-84†	298 lbs.	DSG-15G-84†	305 lbs.	DSG-18G-84†	316 lbs.	39
96"	DSG-12G-96†	330 lbs.	DSG-15G-96†	346 lbs.	DSG-18G-96†	357 lbs.	44
108"	DSG-12G-108†	373 lbs.	DSG-15G-108†	383 lbs.	DSG-18G-108†	397 lbs.	49
120"	DSG-12G-120†	412 lbs.	DSG-15G-120†	424 lbs.	DSG-18G-120†	439 lbs.	55
132"	DSG-12G-132†	453 lbs.	DSG-15G-132†	467 lbs.	DSG-18G-132†	483 lbs.	60
144"	DSG-12G-144††	495 lbs.	DSG-15G-144††	511 lbs.	DSG-18G-144††	528 lbs.	65

† Requires a single pair of center legs †† Requires two pair of center legs

DETAILS and SPECIFICATIONS

TOL ± .500"

ALL DIMENSIONS ARE TYPICAL

DSG-G SERIES - GLASS TOP

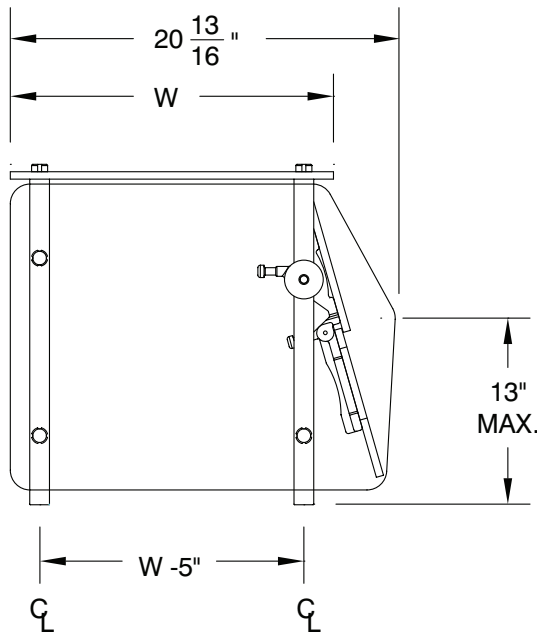

Standard Concealed Mounting Hardware

Requires access below counter for installation.

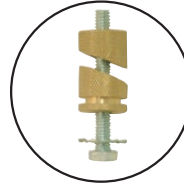

Brass Expander Table Mounting Hardware Included. For traditional undermount installation (1" tubing only)

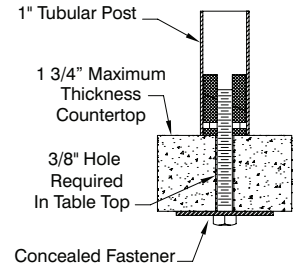

Optional Accessories

Surface Mounting Brackets

Use when access below countertop is not available.



SG-1
Fits 1" Posts
2" O.A. Diameter

(Compatible With All Advance Tabco Food Shields)

