



BASKET RÔTISSERIE

# Rôti-Roaster

## FBP5.520

### DESIGN

Maximize food presentation during the cooking process with this sleek and modern design.

High output rotisserie with six pre-set recipes via a digital control panel. Automatic pre-heat, hold, and cool-down cycles.

208-220 volt - 3-phase heating provides energy savings.

Disassemble in minutes for easy cleaning and grease disposal to minimize labor costs.

Built standard with curved front door and flat rear door. Designed for your operation to load and unload in reach-in and pass-through configurations with front or rear digital control panel options.

Expand menus. Accessory baskets and skewers easily slide into place to cook pork loin, turkey breast, meatloaf, ribs, vegetables, and more. See photos below.

### FEATURES

- Control panel with 6 cooking programs. Automatic pre-heating, alarm at end of cooking cycle, and temperature hold (+145°F).
- Decorative curved front double-glazed glass door with 'Rotisserie' sign mounted on a removable silicone seal. Rear flat glass door. Anti-burn and anti-radiation K.GLASS glass for energy savings & accelerated cooking.
- Removable drip pan with brass drainage plug.
- 2 lights protected by recessed ceramic glass covers.
- Removable internal mounting brackets and baskets for easy cleaning.
- Delivered with 5 baskets (BALD520).



FBP5.520  
(optional stand)



### TECHNICAL DETAILS

Overview of some of the standard features.

	<p>Heat diffused by turbine for a homogeneous distribution of the temperature in the cooking chamber</p>		<p>Silicone gasket for sealing the door when closed</p>		<p>6 cooking programs, alarm at end of cycle, display and programming of cooking time and temperature</p>
--	--	--	---	--	---

### ACCESSORIES

See videos of the [accessories](#) online.

<p><b>BALD) &amp;\$</b> Chicken baskets</p>	<p><b>BAP) &amp;\$</b> Small cuts baskets</p>	<p><b>PD) &amp;\$</b> Stainless steel rack top.</p>	<p><b>FBP.PIED</b> 4 adjustable feet for installation on neutral display.</p>	
---	---	---	---	--

Front view

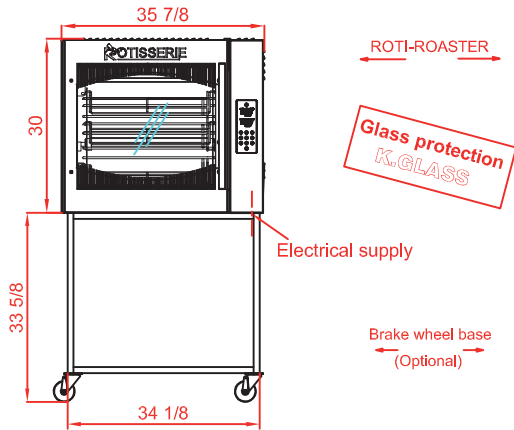

Side view

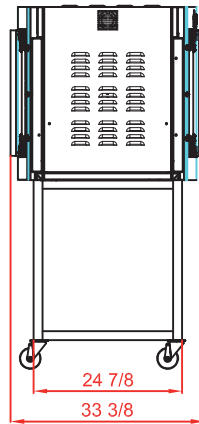

Top view

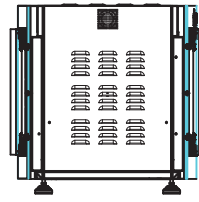
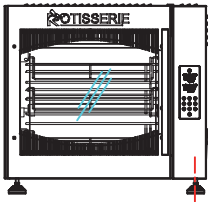
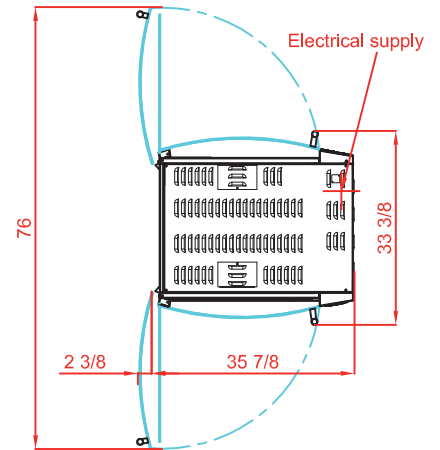

FBP5.520  
(optional stand)



Revised  
October 2020  
July 2022 US

## SPECIFICATIONS

Capacity roasted chickens	15-20 chickens, 5 baskets
Power supply - power	208-240V-60Hz; 14 Amps; 4.9 kW, 3-ph
Weight and size (HxDxW)*	430 Lbs; 63 5/8 x 33 3/8 x 35 7/8 inches
Shipping weight and size*	540 Lbs; 82 3/4 x 40 5/8 x 43 3/8 inches
Warranty	1 year parts and labor

\* with a stand or base cabinet (optional)

DISTRIBUTOR / AGENT

Rotisol France, Inc.

1450 W. 228th St. Unit 10, Torrance, CA 90501

[info@rotisolu.com](mailto:info@rotisolu.com), [www.rotisol.com](http://www.rotisol.com)

Ph: 310 671 7254

800 651 6959

