

IM-0550-AC/AH

[WATER TROUGH ASSY]

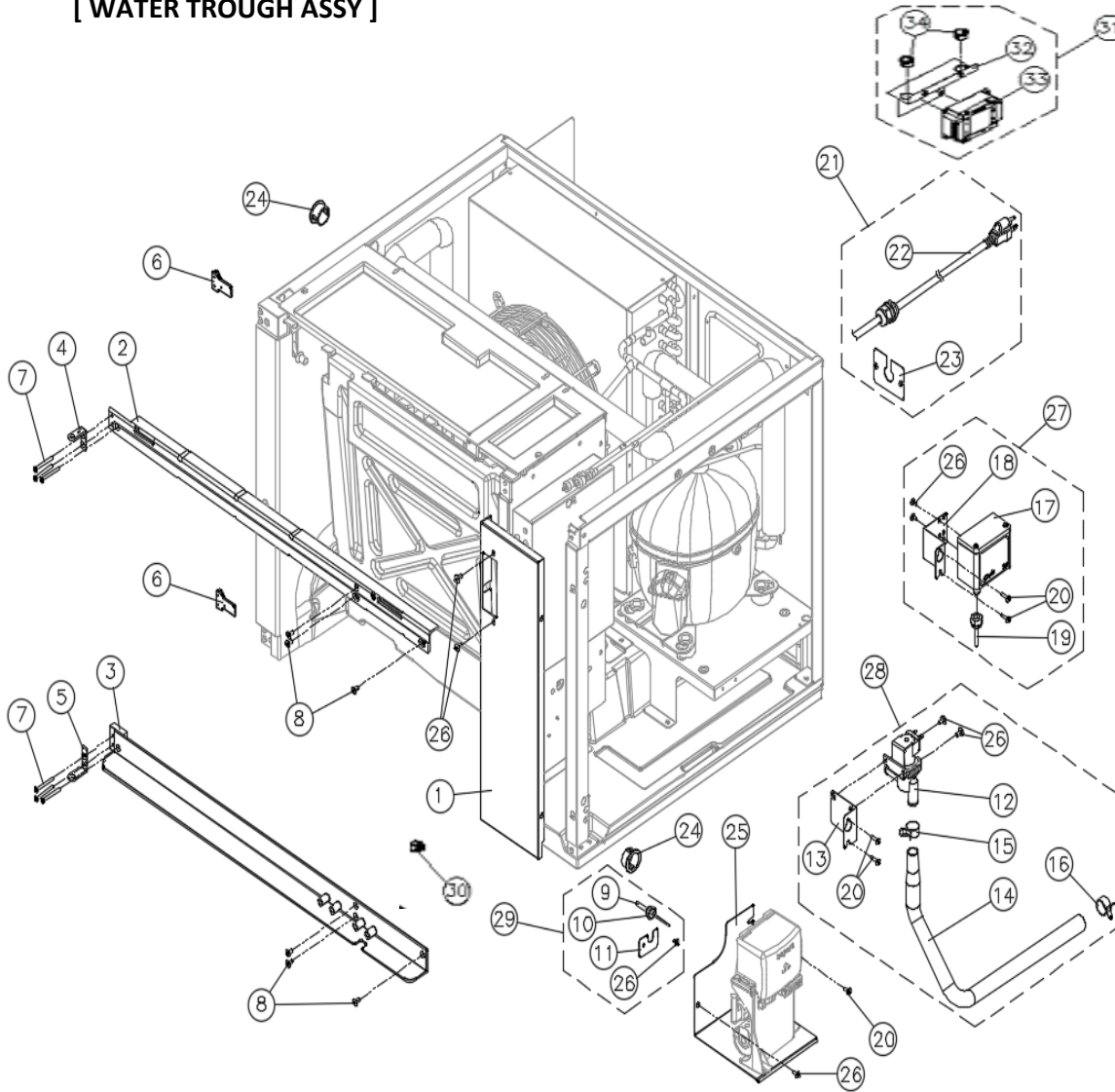

NO	ITEMS	CODE	Q'TY
1	FRONT COVER	317195900	1
2	FRONT TOP SUPPORT	341012401	1
3	FRONT LOWER SUPPORT	341012501	1
4	HINGE BRACKET	321005110	1
5	HINGE BRACKET DOWN	321005210	1
6	HINGE SUPPORT	341012300	2
7	TAPPING SCREW	TFCQ0841RP	6
8	MACHINE SCREW	MFCX1022RP	6
9	CURTAIN SENSOR	701002000	1
10	SENSOR CAP	319009300	1
11	COVER BRACKET	301169400	1
12	DUMP VALVE	340026600	1
13	BRACKET, DUMP VALVE	301169600	1
14	PVC PIPE	229032100	1
15	BAND SPRING 20	203004200	1
16	BAND SPRING 21	203003300	1
17	PRESSURE SWITCH	355012700	1
18	BRACKET	301169700	1
19	SOLDER ADAPTOR	215018510	1
20	TAPPING SCREW	TTCQ0826R	3
21	BKT & POWER CORD ASSY	722012440	1
22	POWER CORD	722012700	1
23	BRACKET POWER CORD	301096700	1
24	GROMMET BUSHING	232003500	2
25	BRACKET	301171201	1
26	MACHINE SCREW	MTCX0816R	5
27	PRESSURE SWITCH COMPLETE ASSY	#17~20,26	1
28	DRAIN VALVE COMPLETE ASSY	#12~16,20,26	1
29	SENSOR PARTS COMPLETE	701003300	1
NEW DESIGN (starting with serial number UL/ ~)			
30	POWER SWITCH	355025100	1
31	NOISE FILTER ASSY	722014380	1
32	NOISE FILTER BRACKET	301171111	1
33	NOISE FILTER	500000900	1
34	BUSHING	232003600	1

