



Ice Machines

Service Manual

PKU0155/PKM0335/PKM0425/PKM0535 MODELS

For technical Assistance please call - MoTak Service @ 1-800.648.6398

Safety Notices

Read these precautions to prevent personal injury:

- Read this manual thoroughly before operating, installing or performing maintenance on the equipment. Failure to follow instructions in this manual can cause property damage, injury or death.
- Routine adjustments and maintenance procedures outlined in this manual are not covered by the warranty.
- Proper installation, care and maintenance are essential for maximum performance and trouble-free operation of your equipment.
- This equipment contains high voltage electricity and refrigerant charge. Installation and repairs are to be performed by properly trained technicians aware of the dangers of dealing with high voltage electricity and refrigerant under pressure. The technician must also be certified in proper refrigerant handling and servicing procedures. All lockout and tag out procedures must be followed when working on this equipment.
- This equipment is intended for indoor use only. Do not install or operate this equipment in outdoor areas.
- As you work on this equipment, be sure to pay close attention to the safety notices in this document. Disregarding the notices may lead to serious injury and/or damage to the equipment.

Definitions

DANGER

Indicates a hazardous situation that, if not avoided, will result in death or serious injury. This applies to the most extreme situations.

⚠ Warning

Indicates a hazardous situation that, if not avoided, could result in death or serious injury.

⚠ Caution

Indicates a hazardous situation that, if not avoided, could result in minor or moderate injury.

Notice

Indicates information considered important, but not hazard-related (e.g. messages relating to property damage).

Important

Indicates useful, extra information about the procedure you are performing.

NOTE: Indicates useful, extra information about the procedure you are performing.

▲Warning

Follow these electrical requirements during installation of this equipment:

- All field wiring must conform to all applicable codes of the authority having jurisdiction. It is the responsibility of the end user to provide the disconnect means to satisfy local codes. Refer to rating plate for proper voltage.
- This appliance must be grounded.
- This equipment must be positioned so that the plug is accessible unless other means for disconnection from the power supply (e.g., circuit breaker or disconnect switch) is provided.
- Check all wiring connections, including factory terminals, before operation. Connections can become loose during shipment and installation.

▲Warning

Follow these precautions to prevent personal injury during installation of this equipment:

- Installation must comply with all applicable equipment fire and health codes with the authority having jurisdiction.
- Connect to a potable water supply only.
- To avoid instability the installation area must be capable of supporting the combined weight of the equipment and product. Additionally the equipment must be level side to side and front to back.
- Remove all removable panels before lifting and installing and use appropriate safety equipment during installation and servicing. Two or more people are required to lift or move this appliance to prevent tipping and/or injury.
- Do not damage the refrigeration circuit when installing, maintaining or servicing the unit.
- Ice machines require a deflector when installed on an ice storage bin. Prior to using a non-OEM ice storage system with this ice machine, contact the bin manufacturer to assure their ice deflector is compatible.
- Prior to installing a non-OEM ice storage system with this ice machine, follow the manufacturers installation procedures and verify the location and installation meets the local/national mechanical codes and stability requirements.

▲ Warning

Follow these precautions to prevent personal injury while operating or maintaining this equipment:

- Refer to nameplate to identify the type of refrigerant in your equipment.
- Only trained and qualified personnel aware of the dangers are allowed to work on the equipment.
- Read this manual thoroughly before operating, installing or performing maintenance on the equipment. Failure to follow instructions in this manual can cause property damage, injury or death.
- Crush/Pinch Hazard. Keep hands clear of moving components. Components can move without warning unless power is disconnected and all potential energy is removed.
- Moisture collecting on the floor will create a slippery surface. Clean up any water on the floor immediately to prevent a slip hazard.
- Never use sharp objects or tools to remove ice or frost. Do not use mechanical devices or other means to accelerate the defrosting process.
- When using cleaning fluids or chemicals, rubber gloves and eye protection (and/or face shield) must be worn.
- Objects placed or dropped in the bin can affect human health and safety. Locate and remove any objects immediately.

DANGER

Do not operate equipment that has been misused, abused, neglected, damaged, or altered/modified from that of original manufactured specifications. This appliance is not intended for use by persons (including children) with reduced physical, sensory or mental capabilities, or lack of experience and knowledge, unless they have been given supervision concerning use of the appliance by a person responsible for their safety. Do not allow children to play with, clean or maintain this appliance without proper supervision.

▲ Warning

Follow these precautions to prevent personal injury during use and maintenance of this equipment:

- It is the responsibility of the equipment owner to perform a Personal Protective Equipment Hazard Assessment to ensure adequate protection during maintenance procedures.
- Do Not Store Or Use Gasoline Or Other Flammable Vapors Or Liquids In The Vicinity Of This Or Any Other Appliance. Never use flammable oil soaked cloths or combustible cleaning solutions for cleaning.
- All covers and access panels must be in place and properly secured when operating this equipment.
- Risk of fire/shock. All minimum clearances must be maintained. Do not obstruct vents or openings.
- Failure to disconnect power at the main power supply disconnect could result in serious injury or death. The power switch DOES NOT disconnect all incoming power.
- All utility connections and fixtures must be maintained in accordance with the authority having jurisdiction.
- Turn off and lockout all utilities (gas, electric, water) according to approved practices during maintenance or servicing.
- Never use a high-pressure water jet for cleaning on the interior or exterior of this unit. Do not use power cleaning equipment, steel wool, scrapers or wire brushes on stainless steel or painted surfaces.
- Two or more people are required to move this equipment to prevent tipping.
- Locking the front casters after moving is the owner's and operator's responsibility. When casters are installed, the mass of this unit will allow it to move uncontrolled on an inclined surface. These units must be tethered/secured to comply with all applicable codes.
- The on-site supervisor is responsible for ensuring that operators are made aware of the inherent dangers of operating this equipment.
- Do not operate any appliance with a damaged cord or plug. All repairs must be performed by a qualified service company.

THIS PAGE INTENTIONALLY LEFT BLANK

Table of Contents

Safety Notices

Requirements - Cleaning - Operation

Model Numbers	11
Ice Machine Warranty Information	11
Warranty	11
Warranty Registration.....	11
Location of Ice Machine.....	12
Ice Machine Clearance Requirements	12
Ice Machine Heat of Rejection	12
Electrical Requirements	13
Water Service/Drains.....	14
Water Supply	14
Water Inlet Lines.....	14
Drain Connections	14
Water Supply and Drain Line Sizing/Connections	15
Descaling and Sanitizing	15
General	15
Detailed Descaling and Sanitizing Procedure.....	15
Toggle Switch Operation	15
Sanitizing Procedure	17
Remove Parts for Cleaning/Descaling.....	18
Remedial Cleaning Procedure	22
Cleaning the Condenser Filter	23
Cleaning the Condenser.....	23
Removal from Service/Winterization	23
Air-cooled Models.....	23
Ice Making Sequence of Operation	24
PKM0335/PKM0425/PKM0535	24
Control Board Timers PKM0335/PKM0425/PKM0535	25
Safety Limits PKM0335/PKM0425/PKM0535	25
Energized Parts Chart PKM0335/PKM0425/PKM0535	27
Operational Checks PKM0335/PKM0425/PKM0535	28
Ice Thickness Check PKM0335/PKM0425/PKM0535.....	28
Minimum/Maximum Slab Weights PKM0335/PKM0425/ PKM0535	28
Ice Making Sequence of Operation	29
PKU0155	29
Energized Parts Chart PKU0155	31

Operational Checks PKU0155	32
Siphon System PKU0155	32
Water Level PKU0155	32
Water Level Check PKU0155	33
Ice Thickness Check PKU0155.....	33
Minimum/Maximum Slab Weight PKU0155	34

Troubleshooting

PKM0335/PKM0425/PKM0535 Models

Control Board Test Mode	35
Diagnosing an Ice Machine that Will Not Run	36
Ice Machine Does Not Cycle Into Harvest when the Harvest Float Is Down/Closed	36
Ice Machine Cycles Into Harvest Before the Harvest Float Is Down/Closed	38
Ice Production Check	39
Installation/Visual Inspection Checklist	40
Water System Checklist	41
Ice Formation Pattern	42
Safety Limits	43
Safety Limit 1	43
Safety Limit 2	43
Safety Limit 3	44
Safety Limit Checklist	45
Analyzing Discharge Pressure	48
Discharge Pressure High Checklist	49
Freeze Cycle Discharge Pressure Low Checklist	49
Analyzing Suction Pressure	50
Suction Pressure High Checklist.....	52
Suction Pressure Low Checklist.....	52
Harvest Valve	53
Harvest Valve Analysis	54
Comparing Evaporator Inlet/Outlet Temperatures	56
Discharge Line Temperature Analysis	57
Refrigeration Component Diagnostics	58
Procedure	58
Final Analysis	59
Refrigeration Component Diagnostic Chart	60

**Troubleshooting
PKU0155 Model**

Troubleshooting an Ice Machine Will Not Run 63

Troubleshooting Ice Thickness Control Circuitry 64

 Ice Machine Does Not Cycle Into Harvest when Water
 Contacts the Ice Thickness Control Probe..... 64

 Ice Machine Cycles Into Harvest Before Water Contact
 with the Ice Thickness Probe 66

Ice Production Check 67

Installation and Visual Inspection Checklist 68

Water System Checklist 68

Ice Formation Pattern 70

Safety Limit Feature 72

 Safety Limits..... 72

 Safety Limit #1 72

 Safety Limit #2 72

 Safety Limit Stand-by Mode..... 72

 Safety Limit Checklist 75

Analyzing Discharge Pressure 78

 Discharge Pressure High Checklist 79

 Freeze Cycle Discharge Pressure Low Checklist 79

Analyzing Suction Pressure 80

 Suction Pressure High Checklist..... 82

 Suction Pressure Low Checklist..... 82

Harvest Valve 83

 Harvest Valve Analysis 84

Comparing Evaporator Inlet/Outlet Temperatures 87

Discharge Line Temperature..... 88

Refrigeration Component Diagnostic Chart 89

 Procedure 89

 Final Analysis 90

 Refrigeration Component Diagnostic Chart PKU0155 91

 Ice Quality Is Poor — Cubes are Shallow, Incomplete
 or White..... 93

 Freeze Cycle Is Long, Low Ice Production 94

 Ice Machine Runs and No Ice Is Produced 95

Specifications

Main Fuse	97
Bin Switch	98
Float Switch	99
Compressor Electrical Diagnostics	101
Fan Cycle Control	103
High Pressure Cutout (HPCO) Control	105
Refrigerant Recovery/Evacuation	106
Definitions	106
Refrigerant Re-use Policy	107
Recovery and Recharging Procedures	109
System Contamination Cleanup.....	111
Determining Severity of Contamination	111
Cleanup Procedure	113
Severe System Contamination Cleanup Procedure.....	114
Liquid Line filter driers	115
Replacing Pressure Controls without Removing Refrigerant Charge	116
Refrigerant Amount	117
Ice Machine Normal Operation Charts	117
PKU0155 Self Contained Ice Machine.....	118
PKM0335 Modular Ice Machine	119
PKM0425 Modular Ice Machine	120
PKM0535 Modular Ice Machine	121
Wiring Diagram	122
PKU0155 Wiring Diagram	123
PKM0335/PKM0425/PKM0535 Wiring Diagram	124
Electronic Control Board	125
Control Board Schematic PKM0335/PKM0425/PKM0535 .	125
Control Board Schematic PKU0155.....	126
Refrigeration Tubing Schematic	127

Requirements - Cleaning - Operation

Model Numbers

This manual covers the following models:

PKU0155SA - Small Cube, Air-cooled, Undercounter Model

PKU0155FA - Full Cube Air-cooled, Undercounter Model

PKM0335SA - Small Cube, Air-cooled, Modular Model

PKM0335FA - Full Cube Air-cooled, Modular Model

PKM0425SA - Small Cube, Air-cooled, Modular Model

PKM0425FA - Full Cube Air-cooled, Modular Model

PKM0535SA - Small Cube, Air-cooled, Modular Model

PKM0535FA - Full Cube Air-cooled, Modular Model

PKB0425 - 22" Wide Modular Bin

PKB0535 - 30" Wide Modular Bin

Ice Machine Warranty Information

Warranty

For warranty information visit:

- [Warranty Coverage Information](#)
- [Warranty Registration](#)
- [Warranty Verification](#)

Warranty coverage begins the day the ice machine is installed.

Warranty Registration

Completing the warranty registration process is a quick and easy way to protect your investment.

Location of Ice Machine

The location selected for the ice machine must meet the following criteria. If any of these criteria are not met, select another location.

- The location must be indoors.
- The location must be free of airborne and other contaminants.
- Air temperature: Must be at least 40°F (4°C) but must not exceed 110°F (43.4°C).
- The location must not be near heat-generating equipment or in direct sunlight.
- The location must be capable of supporting the weight of the ice machine and a full bin of ice.
- The location must allow enough clearance for water, drain, and electrical connections in the rear of the ice machine.
- The location must not obstruct airflow through or around the ice machine (condenser air flow is in the back and out the sides). Refer to the chart for clearance requirements.
- The ice machine must be protected if it will be subjected to temperatures below 32°F (0°C). Failure caused by exposure to freezing temperatures is not covered by the warranty.

Ice Machine Clearance Requirements

PKU0155 Top and Sides 5" (13 cm) Back 5" (13 cm)

PKM0335 Top and Sides 12" (30 cm) Back 5" (13 cm)

PKM0425 and PKM0535 Top and Sides 8" (20 cm) Back 5" (13 cm)

Do not obstruct ice machine vents or openings.

Caution

The ice machine must be protected if it will be subjected to temperatures below 32°F (0°C). Failure caused by exposure to freezing temperatures is not covered by the warranty.

Ice Machine Heat of Rejection

Series Ice Machine	Heat of Rejection ¹	
	Air Conditioning ²	Peak
PKU0155	2200	2600
PKM0335	4600	5450
PKM0425	5400	6300
PKM0535	5300	6100

¹ B.T.U./Hour

² Because the heat of rejection varies during the ice making cycle, the figure shown is an average.

Ice machines, like other refrigeration equipment, reject heat through the condenser. It is helpful to know the amount of heat rejected by the ice machine when sizing air conditioning equipment where self-contained air-cooled ice machines are installed.

Electrical Requirements

Voltage

The maximum allowable voltage variation is $\pm 10\%$ of the rated voltage on the ice machine model/serial number plate at start-up (when the electrical load is highest).

Fuse/Circuit Breaker

A separate fuse/circuit breaker must be provided for each ice machine.

Total Circuit Ampacity

The total circuit ampacity is used to help select the wire size of the electrical supply.

The wire size (or gauge) is also dependent upon location, materials used, length of run, etc., so it must be determined by a qualified electrician.

Refer to ice machine data plate, for electrical requirements. The ice machine data plate information overrides all other published data.

▲Warning

All wiring must conform to local, state and national codes.

▲Warning

The ice machine must be grounded in accordance with national and local electrical code.

Water Service/Drains

WATER SUPPLY

Local water conditions may require treatment of the water to inhibit scale formation, filter sediment, and remove chlorine odor and taste.

Important

If you are installing a water filter system, refer to the Installation Instructions supplied with the filter system for ice making water inlet connections.

▲Warning

For ice making, connect to a potable water supply only.

WATER INLET LINES

Follow these guidelines to install water inlet lines:

- Do not connect the ice machine to a hot water supply. Be sure all hot water restrictors installed for other equipment are working. (Check valves on sink faucets, dishwashers, etc.)
- If water pressure exceeds the maximum recommended pressure, 80 psig (5.5 bar) obtain a water pressure regulator from your Koolaire distributor.
- Install a water shut-off valve for ice making potable water.
- Insulate water inlet lines to prevent condensation.

DRAIN CONNECTIONS

Follow these guidelines when installing drain lines to prevent drain water from flowing back into the ice machine and storage bin:

- Drain lines must have a 1.5-inch drop per 5 feet of run (2.5 cm per meter), and must not create traps.
- The floor drain must be large enough to accommodate drainage from all drains.
- Install a tee to vent the ice machine drain to the atmosphere.
- Insulate drain lines to prevent condensation.
- Install a separate bin drain and ice machine drain.

⚠Caution

Plumbing must conform to state and local codes

WATER SUPPLY AND DRAIN LINE SIZING/CONNECTIONS

Water Temperature	40°F (4°C) min. 90°F (32.2°C) max.
Water Pressure	20 psi (1.38 bar) min. 80 psi (5.5 bar) max.
Ice Machine Fitting	3/8" Female Pipe Thread
Tubing Size Up to Ice Machine Fitting	3/8" (9.5 mm) min. inside diameter

Descaling and Sanitizing**GENERAL**

Descale and sanitize the ice machine every six months for efficient operation. If the ice machine requires more frequent cleaning and sanitizing, consult a qualified service company to test the water quality and recommend appropriate water treatment.

The ice machine must be taken apart for cleaning and sanitizing.

⚠ Caution

Use only Manitowoc Ice Machine Cleaner/Descaler (part number 9405463) and Sanitizer (part number 9405653). It is a violation of Federal law to use these solutions in a manner inconsistent with their labeling. Read and understand all labels printed on bottles before use.

DETAILED DESCALING AND SANITIZING PROCEDURE

Ice machine cleaner/descaler is used to remove lime scale and mineral deposits. Ice machine sanitizer disinfects and removes algae and slime.

TOGGLE SWITCH OPERATION

Moving the toggle switch to clean will start a Clean cycle.

- **Setting the ice machine to stop after the clean cycle:** Place the toggle switch in the clean position. The ice machine will stop after the clean cycle.
- **Pausing the cleaning cycle:** Move the toggle switch to Off. Moving the toggle switch to clean will restart the clean cycle.
- **Setting the ice machine to start ice making after the clean cycle:** Place the toggle switch in the Ice position more than 2 minutes into the clean cycle.

Step 1 Remove/open the front door to access the evaporator compartment. Ice must not be on the evaporator during the descaling and sanitizing cycle. Set the toggle switch to the OFF position after ice falls from the evaporator at the end of a harvest cycle. Or, set the switch to OFF and allow the ice to melt off the evaporator

⚠ Caution

Never use anything to force ice from the evaporator. Damage may result.

Step 2 Remove all ice from the bin.

⚠ Warning

Wear rubber gloves and safety goggles (and/or face shield) when handling Ice Machine Descaler/Cleaner or Sanitizer.

⚠ Caution

Do not mix Ice Machine Cleaner/Descaler and Sanitizer solutions together. It is a violation of Federal law to use these solutions in a manner inconsistent with their labeling.

Step 3 Place the toggle switch in the CLEAN or WASH position. Water will flow through the water dump valve and down the drain. Wait until the water trough refills, then add the proper amount of ice machine cleaner/descaler.

Model	Amount of Cleaner/Descaler
PKU0155	2 ounces (60 ml)
PKM0335/PKM0425/PKM0535	5 ounces (150 ml)

Step 4 Wait until the cycle is complete, then place the toggle switch in the off position and disconnect power and water supplies to the ice machine (and dispenser when used).

Step 5 Remove parts for descaling.

Refer to the proper parts removal for your machine. Continue with Step 6 when the parts have been removed. Refer to “PKM0335/PKM0425/PKM0535 Parts Removal” on page 20 or “PKU0155 Parts Removal” on page 21.

Step 6 Mix a solution of cleaner/descaler and lukewarm water. Depending on the amount of mineral buildup, a larger quantity of solution may be required. Use the ratio in the table below to mix enough solution to thoroughly clean all parts.

Solution Type	Water	Mixed with
Cleaner/Descaler	1 gal. (4 l)	16 oz (500 ml) cleaner/descaler

Step 7 Use half of the cleaner/descaler & water solution to clean all components. The solution will foam when it contacts lime scale and mineral deposits; once the foaming stops use a soft bristle brush, sponge or cloth (not a wire brush) to carefully clean the parts. Soak the parts for 5 minutes (15 – 20 minutes for heavily scaled parts). Rinse all components with clean water.

Step 8 While components are soaking, use half of the cleaner/descaler & water solution to clean all foodzone surfaces of the ice machine and bin. Use a nylon brush or cloth to thoroughly clean the following ice machine areas:

- Evaporator plastic parts – including top, bottom and sides
- Bin bottom, sides and top
- Rinse all areas thoroughly with clean water.

SANITIZING PROCEDURE

Step 9 Mix a solution of sanitizer and warm water.

Solution Type	Water	Mixed With
Sanitizer	3 gal. (12 l)	2 oz (60 ml) sanitizer

Step 10 Use half of the sanitizer/water solution to sanitize all removed components. Use a spray bottle to liberally apply the solution to all surfaces of the removed parts or soak the removed parts in the sanitizer/water solution. Do not rinse parts after sanitizing.

Step 11 Use half of the sanitizer/water solution to sanitize all foodzone surfaces of the ice machine and bin. Use a spray bottle to liberally apply the solution. When sanitizing, pay particular attention to the following areas:

- Evaporator plastic parts - including top, bottom and sides
- Bin bottom, sides and top

Do not rinse the sanitized areas.

Step 12 Replace all removed components.

Step 13 Wait 20 minutes.

Step 14 Reapply power and water to the ice machine and place the toggle switch in the CLEAN or WASH position.

Step 15 Wait until the water trough refills, then add the proper amount of ice machine sanitizer to the water trough.

Model	Amount of Sanitizer
PKU0155	2.2 ounces (66 ml)
PKM0335/PKM0425/PKM0535	3 ounces (90 ml)

After the sanitize cycle is complete move the toggle switch to the ice position to start ice making.

REMOVE PARTS FOR CLEANING/DESCALING

▲Warning

Disconnect electric power to the ice machine at the electric switch box before proceeding.

PKM0335/PKM0425/PKM0535 Parts Removal

A. Remove the water curtain

- Gently flex the curtain in the center and remove it from the right side.
- Slide the left pin out.

B. Remove the water trough

- Depress tabs on right and left side of the water trough.
- Allow front of water trough to drop as you pull forward to disengage the rear pins.

C. Remove the ice thickness and harvest float switches

- Pull the float switch straight down to disengage.
- Lower the float switch until the wiring connector is visible.
- Disconnect the wire lead from the float switch.
- Remove the float switch from the ice machine.

D. Remove the water distribution tube.

NOTE: Distribution tube thumbscrews are retained to prevent loss. Loosen thumbscrews but do not pull thumbscrews out of distribution tube.

- Loosen the two outer screws (do not remove screws completely they are retained to prevent loss) and pull forward on the distribution tube to release from slip joint.
- Disassemble distribution tube by loosening the two (2) middle thumbscrews and dividing the distribution tube into two pieces.
- Proceed to page 18 Step 6.

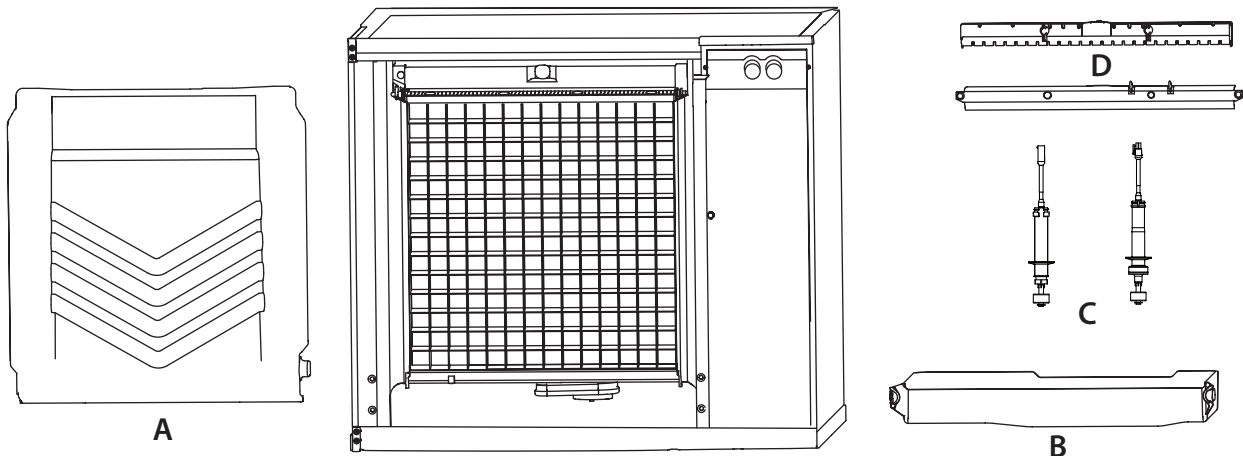

PKU0155 Parts Removal

1. Remove Two Thumbscrews and Water Pump Cover.
2. Remove the Vinyl Hose Connecting the Water Pump and Water Distribution Tube.
3. Remove Water Pump:
 - Disconnect the water pump power cord.
 - Loosen the screws securing the pump mounting bracket to the bulkhead.
 - Lift the pump and bracket assembly off the mounting screws.
4. Remove the Ice Thickness Probe by compressing the side of the ice thickness probe near the top hinge pin and remove it from the bracket.

NOTE: At this point, the ice thickness probe can easily be cleaned. If complete removal is desired, follow the ice thickness probe wire to the bulkhead grommet (exit point) in the back wall. Pop the bulkhead grommet out of the back wall by inserting fingernails or a flat object between the back wall and the grommet and prying forward. Pull the bulkhead grommet and wire forward until the connector is accessible, then disconnect the wire lead from the connector.

Ice Thickness Probe Cleaning

- Mix a solution of ice machine cleaner and water (2 ounces of cleaner to 16 ounces of water) in a container.
- Soak the ice thickness probe a minimum of 10 minutes.

Clean all ice thickness probe surfaces and verify the ice thickness probe cavity is clean. Rinse thoroughly with clean water, then dry completely. Incomplete rinsing and drying of the ice thickness probe can cause premature harvest.

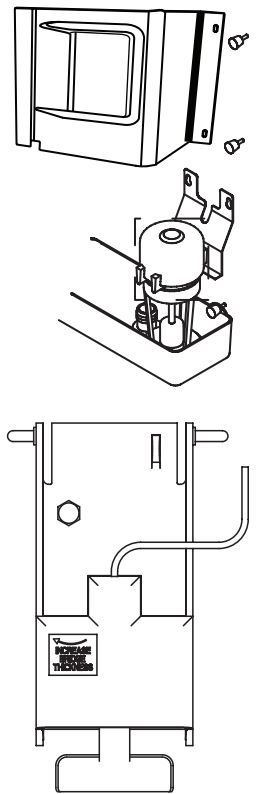

5. Remove the Water Distribution Tube

- A. Loosen the two thumbscrews, which secure the distribution tube.
- B. Lift the right side of the distribution tube up off the locating pin.
- C. Slide the distribution tube back.
- D. Slide the distribution tube to the right and remove.

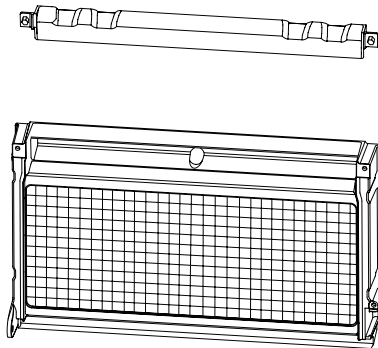

Disassemble the distribution tube - Twist both of the inner tube ends until the tabs line up with the keyway and pull the inner tube ends outward.

6. Remove the Float Valve

- Turn the splash shield counterclockwise one or two turns and pull the float valve forward and off the mounting bracket.
- Disconnect the water inlet tube from the float valve at the compression fitting.
- Remove the cap and filter screen for cleaning.

7. Remove the Water Trough

- Apply downward pressure on the siphon tube and remove from the bottom of the water trough.
- Remove the upper thumbscrew and while supporting the water trough remove the two thumbscrews from beneath the water trough.

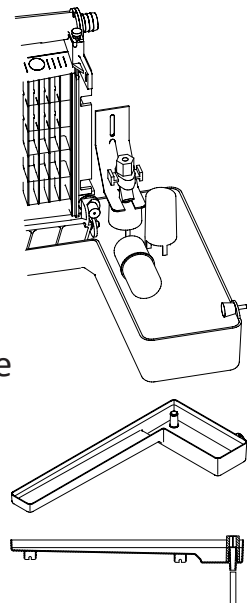

8. Remove the ice damper

- Grasp ice damper and apply pressure toward the left hand mounting bracket.
- Apply pressure to the right-hand mounting bracket with thumb.
- Pull ice damper forward when the right-hand ice damper pin disengages.

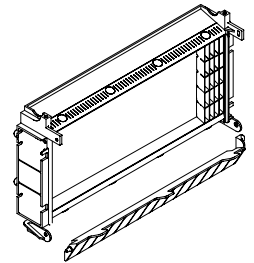

Installation

- Place ice damper pin in left-hand mounting bracket and apply pressure toward the left-hand mounting bracket.
- Apply pressure to the right-hand mounting bracket with thumb.
- Push ice damper toward evaporator until right-hand damper pin engages.

9. Remove the Bin Door

- Grasp the rear of the bin door and pull bin door forward approximately 5" (13 cm).
- Slide bin door to the rear while applying upward pressure (The rear door pins will ride up into the track slot and slide backward to the stop tab).
- While applying pressure against the bin door pull down on the rear of each bin door track until the door pins clear the stop tabs.
- Slide the rear door pins off the end and then below the door track. Slide bin door forward allowing the back of the door to lower into the bin. Continue forward with the bin door until the front pins bottom out in the track.
- Lift right side of door until the front pins clear the track, then remove door from bin.
- Remove rollers (4) from all door pins.

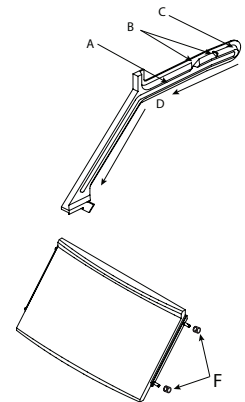

10. Continue with Step 6 on page 18

Remedial Cleaning Procedure

This procedure descales all components in the water flow path, and is used between the bi-yearly detailed descaling and sanitizing procedure.

Ice machine cleaner/descaler is used to remove lime scale and mineral deposits. Ice machine sanitizer disinfects and removes algae and slime.

NOTE: Although not required and dependent on your installation, removing the ice machine top cover may allow easier access.

Step 1 Ice must not be on the evaporator during the cycle. Follow one of the methods below:

- Move the toggle switch to the OFF position at the end of a harvest cycle after ice falls from the evaporator.
- Move the toggle switch to the OFF position and allow the ice to melt.

Caution

Never use anything to force ice from the evaporator. Damage may result.

Step 2 Open the front door and move the toggle switch to the CLEAN or WASH position. Wait until the water trough refills (approximately 1 minute) and then add the proper amount of Ice Machine cleaner/descaler to the water trough.

Model	Amount of Cleaner/Descaler
PKU0155	2 ounces (60 ml)
PKM0335/PKM0425/PKM0535	5 ounces (150 ml)

Step 3 After 1 minute place the toggle switch in the ICE position and close and secure the front door. The ice machine will automatically start ice making after the cycle is complete (approximately 24 minutes).

Cleaning the Condenser Filter

The washable filter is designed to catch dust, dirt, lint and grease. Clean the filter with a mild soap and water.

Cleaning the Condenser

General

▲Warning

Disconnect electric power to the ice machine head section and the remote condensing unit at the electric service switches before cleaning the condenser.

A dirty condenser restricts airflow, resulting in excessively high operating temperatures. This reduces ice production and shortens component life.

- Clean the condenser at least every six months.

▲Warning

The condenser fins are sharp. Use care when cleaning them.

- Shine a flashlight through the condenser to check for dirt between the fins.
- Blow compressed air or rinse with water from the inside out (opposite direction of airflow).
- If dirt still remains call a service agent to clean the condenser.

Removal from Service/Winterization

AIR-COOLED MODELS

1. Descale and sanitize the ice machine.
2. Place the toggle switch in the off position to turn off the ice machine.
3. Turn off the water supply, disconnect and drain the incoming ice-making water line at the rear of the ice machine and drain the water trough.
4. Blow with compressed air to remove water from ice machine:
 - PKM0335/PKM0425/PKM0535 - Energize the ice machine, wait one minute for the water inlet valve to open and blow compressed air in both the incoming water and the drain openings in the rear of the ice machine to remove all water.
 - PKU0155 - Blow compressed air in both the incoming water and the drain openings in the rear of the ice machine to remove all water.
5. Place the toggle switch in the off position and disconnect the electric power at the circuit breaker or the electric service switch.
6. Fill spray bottle with sanitizer and spray all interior food zone surfaces. Do not rinse and allow to air dry.
7. Replace all panels.

Ice Making Sequence of Operation

PKM0335/PKM0425/PKM0535

NOTE: The toggle switch must be in the ICE position and the water curtain must be closed before the ice machine will start.

1. Water Purge Cycle

The ice machine purges any remaining water from the water trough down the drain.

2. Freeze Cycle

Prechill - The refrigeration system chills the evaporator before water flow over the evaporator starts. The water inlet valve energizes during the pre-chill and remains on until the ice thickness float switch is satisfied.

Freeze - Water flowing across the evaporator freezes and builds ice on the evaporator. After a sheet of ice has formed, the Harvest float switch signals the control board to start a harvest cycle.

3. Harvest Cycle

Any remaining water is purged down the drain as refrigerant gas warms the evaporator. When the evaporator warms, the sheet of cubes slides off the evaporator and into the storage bin. If all cubes fall clear of the water curtain, the ice machine starts another freeze cycle.

4. Full Bin Cycle

If the water curtain is held open by ice cubes the ice machine shuts off. When the water curtain closes the ice machine starts a new cycle at the water purge.

CONTROL BOARD TIMERS PKM0335/PKM0425/PKM0535

- The ice machine is locked into the freeze cycle for 6 minutes before a harvest cycle can be initiated.
- The freeze time lock in feature is bypassed on the initial cycle (manual start or after a full bin/safety limit condition).
- If the harvest float switch is in the down position for 10 continuous seconds during the start of an initial freeze cycle, a harvest sequence is initiated. If the harvest float is in the down position in subsequent cycles a safety limit 3 cycle is initiated.
- The maximum freeze time is 35 minutes (60 minutes prior to software revision 3.2) at which time the control board automatically initiates a harvest sequence.
- The maximum harvest time is 3.5 minutes. The control board automatically initiates a freeze sequence when these times are exceeded.
- The ice machine will continue to fill with water for up to six minutes, or until the high water float opens for 5 continuous seconds. The control board will energize the water inlet valve one more time 3 minutes into the freeze cycle.

SAFETY LIMITS PKM0335/PKM0425/PKM0535

Safety limits are stored and indicated by the control board. The number of cycles required to stop the ice machine varies for each safety limit.

Safety limits can be reset by cycling the toggle switch Off/On and starting a new ice making cycle.

A safety limit is indicated by a flashing light on the control board.

Safety Limit 1

If the freeze time reaches 35 minutes, the control board automatically initiates a harvest cycle.

- After 3 consecutive 35 minute cycles control board light SL#1 light will flash on/off at 1 second intervals.
- If 6 consecutive 35-minute freeze cycles occur, the ice machine stops and the SL#1 light on the control board will be on continuously.

NOTE: Prior to control board software revision 3.2 the maximum freeze time is 60 minutes rather than 35 minutes.

Safety Limit 2

If the harvest time reaches 3.5 minutes, the control board automatically returns the ice machine to the freeze cycle.

- If three consecutive 3.5 minute harvest cycles occur the SL#2 light on the control board will flash on/off at 1 second intervals. After 75 consecutive 3.5 minutes harvest cycles the SL#2 light will be energized continuously.
- If 100 consecutive 3.5 minute harvest cycles occur, the ice machine stops and the SL#2 light on the control board will be on continuously.

Safety Limit 3

If the harvest float switch hasn't opened for 10 continuous seconds within 4 minutes of the water inlet valve energizing the ice machine stops.

- Safety Limit 3 is bypassed on the initial cycle (manual start or after a full bin/safety limit condition). For all subsequent cycles the ice machine stops for 30 minutes when the water inlet valve is energized for 4 minutes and the harvest float valve didn't open. Control board lights SL#1 and SL#2 will flash on/off at 1 second intervals.
- The ice machine automatically restarts at the end of the 30 minute delay period and stops flashing the control board lights.
- If 100 consecutive failures occur the ice machine stops and the SL#1 & SL#2 lights flash on/off at 1 second intervals.
- SL#1 & SL#2 will flash 3 times on startup and automatically erase after 100 normal cycles.

ENERGIZED PARTS CHART PKM0335/PKM0425/PKM0535

ICE MAKING SEQUENCE OF OPERATION	Water Pump	Harvest Valve	Water Inlet Valve	Dump Valve	Compressor & Condenser Fan Motor*	Harvest Float Switch	Ice Thickness Float Switch	Length of Time
Initial Start-up	On	On	Off	On	Off	Closed	Closed	45 seconds
1a. Water purge	Off	Off	Off	Off	Off	Closed	Closed	5 seconds
1b. Delay period								
2. Refrigeration System Start-up	Off	On	Off	Off	Off	Closed	Closed	5 seconds
2a. Equalize Pressure	Off	On	Off	Off	On	Closed	Closed	5 seconds
2b. Compressor Start-up								
3. Freeze Sequence	Off	Off	On	Off	On	Open	Closed	120 Seconds initial cycle
3. Pre chill								Thereafter 30 seconds
4. Freeze	On	Off	On	Off	On	Open then Closed	Closed then Open	Until Harvest Float Switch closes for 10 continual seconds
Harvest Sequence	On	On	Off	On	On	Closed	Closed	45 seconds
5. Water Purge								
6. Harvest	Off	On	Off	Off	On	Closed	Closed	Bin switch activation
7. Automatic Shut-off	Off	Off	Off	Off	Off	Closed	Closed	Until bin switch re-closes

* Condenser Fan Motor: The fan motor is wired through a fan cycle pressure control; therefore, it may cycle on and off.

Operational Checks PKM0335/PKM0425/PKM0535

ICE THICKNESS CHECK PKM0335/PKM0425/PKM0535

After a harvest cycle, inspect the ice cubes in the ice storage bin. The ice bridge connects the ice cubes and must be set to maintain an ice bridge thickness of 1/8" (3 mm). To adjust the thickness of the bridge refer to ice thickness adjustment.

The ice thickness float switch is factory-set to maintain the ice bridge thickness at 1/8" (3 mm).

NOTE: Make sure the water curtain is in place when performing this check. It prevents water from splashing out of the water trough.

1. Inspect the bridge connecting the cubes. It should be about 1/8" (3 mm) thick.
2. If adjustment is necessary, turn the ice thickness float switch clockwise to increase bridge thickness, counterclockwise to decrease bridge thickness. Adjust to achieve a 1/8" (3 mm) bridge thickness.

NOTE: The float can be adjusted with a 3/4" wrench while the water trough is in-place. Test run two cycles to verify ice bridge thickness.

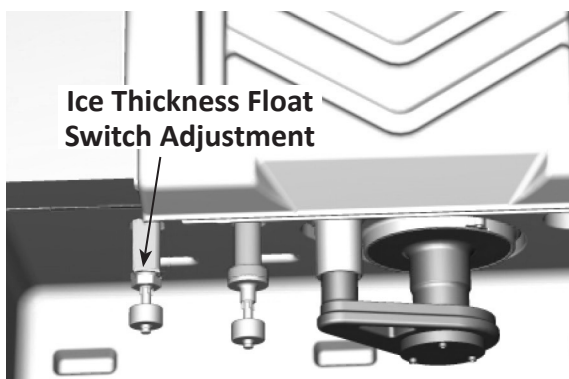

MINIMUM/MAXIMUM SLAB WEIGHTS PKM0335/PKM0425/PKM0535

Adjust ice thickness to meet 1/8" (3 mm) bridge thickness and minimum/maximum weight per cycle.

Model	Minimum Ice Weight Per Cycle	Maximum Ice Weight Per Cycle
PKM0425	3.4 lbs 1542 g	3.9 lbs 1769 g
PKM0535	4.125 lbs 1871 g	4.75 lbs 2154 g

Ice Making Sequence of Operation

PKU0155

NOTE: The toggle switch must be in the ICE position and the water curtain must be closed before the ice machine will start.

1. Pressure Equalization

Before the compressor starts the harvest valve is energized for 15 seconds to equalize pressures during the initial refrigeration system start-up.

2. Refrigeration System Start-up

The compressor starts after the 15-second pressure equalization, and remains on throughout the entire Freeze and Harvest Sequences. The harvest valve remains on for 5 seconds during initial compressor start-up and then shuts off.

At the same time the compressor starts, the condenser fan motor (air-cooled models) is supplied with power throughout the entire Freeze and Harvest Sequences. The fan motor is wired through a fan cycle pressure control, therefore it may cycle on and off. (The compressor and condenser fan motor are wired through the relay. As a result, any time the relay coil is energized, the compressor and fan motor are supplied with power.)

FREEZE SEQUENCE

3. Prechill

The compressor is on for 30 seconds prior to water flow to prechill the evaporator.

4. Freeze

The water pump starts after the 30-second prechill. An even flow of water is directed across the evaporator and into each cube cell, where it freezes.

When sufficient ice has formed, the water flow (not the ice) contacts the ice thickness probe. After approximately 7 seconds of continual water contact, the Harvest Sequence is initiated. The ice machine cannot initiate a Harvest Sequence until a 6-minute freeze time has been surpassed.

HARVEST SEQUENCE

5. Harvest

The water pump de-energizes stopping flow over the evaporator. The rising level of water in the sump trough diverts water out of the overflow tube, purging excess minerals from the sump trough. The harvest valve also opens to divert hot refrigerant gas into the evaporator.

The refrigerant gas warms the evaporator causing the cubes to slide, as a sheet, off the evaporator and into the storage bin. The sliding sheet of cubes contacts the ice damper, opening the bin switch.

The momentary opening and re-closing of the bin switch terminates the Harvest Sequence and returns the ice machine to the Freeze Sequence (steps 3 - 4).

AUTOMATIC SHUT-OFF

6. Automatic Shut-off

When the storage bin is full at the end of a harvest sequence, the sheet of cubes fails to clear the ice damper and will hold it down. After the ice damper is held open for 7 seconds, the ice machine shuts off. The ice machine remains off for 3 minutes before it can automatically restart.

The ice machine remains off until enough ice has been removed from the storage bin to allow the ice to fall clear of the damper. As the ice damper swings back to the operating position, the bin switch re-closes and the ice machine restarts (steps 1 - 2), provided the 3 minute delay period is complete.

ENERGIZED PARTS CHART PKU0155

ICE MAKING SEQUENCE OF OPERATION	Control Board Relays			Relay		Length of Time
	1 Water Pump	2 Harvest Valve	3 Relay Coil	3A Compressor	3B Compressor Fan Motor*	
Initial Start-up 1. Water Purge	Off	On	Off	Off	Off	15 Second
2. Refrigeration Start-Up	Off	On	On	On	On	5 Seconds
Freeze Sequence 3. Prechill	Off	Off	On	On	On	30 Seconds
4. Freeze	On	Off	On	On	On	Until 7 Second Water Contact W/ Ice Thickness Probe
Harvest Sequence 5. Harvest	Off	On	On	On	On	Bin Switch Activation
Automatic Shut-off 6. Automatic Shut-off	On	Off	On	On	On	Until Bin Switch Re-closes

* Condenser Fan Motor: The fan motor is wired through a fan cycle pressure control; therefore, it may cycle on and off

Operational Checks PKU0155

SIPHON SYSTEM PKU0155

To reduce mineral build-up and cleaning frequency, the water in the sump trough must be purged during each harvest cycle.

When the water pump de-energizes, the level in the water trough rises above the standpipe, starting a siphon action.

The siphon action stops when the water level in the sump trough drops. When the siphon action stops, the float valve refills the water trough to the correct level.

Follow steps 1 through 6 under water level check to verify the siphon system functions correctly.

WATER LEVEL PKU0155

Check the water level while the ice machine is in the ice mode and the water pump is running. The correct water level is 1/4" (6.3 mm) to 3/8" (9.5 mm) below the top of the standpipe. A line in the water trough indicates the correct level.

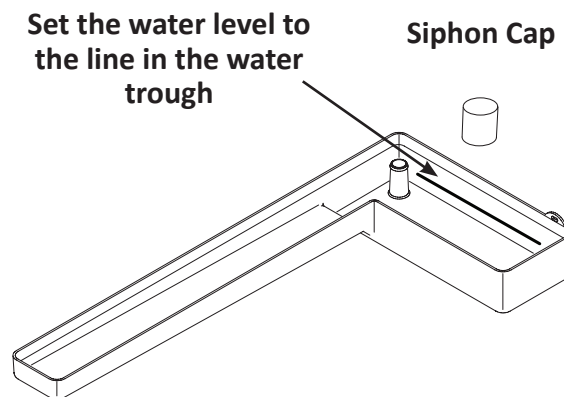

WATER LEVEL CHECK PKU0155

The float valve is factory-set for the proper water level. If adjustments are necessary:

1. Verify the ice machine is level.
2. Remove the siphon cap from the standpipe.
3. Place the main ON/OFF/WASH toggle switch to the ON position, and wait until the float valve stops adding water.
4. Adjust the water level to (1/4" to 3/8" [6.3 to 9.5 mm] below the standpipe) the line in the water trough:
 - A. Loosen the two screws on the float valve bracket.
 - B. Raise or lower the float valve assembly as necessary, then tighten the screws.
5. Move the main ON/OFF/WASH toggle switch to the OFF position. The water level in the trough will rise above the standpipe and run down the drain.
6. Replace the siphon cap on the standpipe, and verify water level and siphon action by repeating steps 3 through 5.

ICE THICKNESS CHECK PKU0155

After a harvest cycle, inspect the ice cubes in the ice storage bin. The ice thickness probe is set to maintain an ice bridge of 1/8" (3.2 mm). If an adjustment is needed, follow the steps below.

1. Turn the ice thickness probe adjustment screw clockwise for a thicker ice bridge, or counterclockwise for a thinner ice bridge.
2. Make sure the ice thickness probe wire and bracket does not restrict movement of the probe.

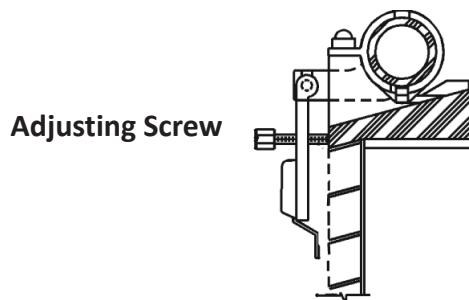

MINIMUM/MAXIMUM SLAB WEIGHT PKU0155

Adjust ice thickness to meet 1/8" (3 mm) bridge thickness and minimum/maximum weight per cycle.

Model	Minimum Ice Weight Per Cycle	Maximum Ice Weight Per Cycle
PKM0335	3.4 lbs 1542 g	3.9 lbs 1769 g

Troubleshooting

PKM0335/PKM0425/PKM0535 Models

Control Board Test Mode

NOTE: The water curtain/bin switch can be open or closed and does not affect the operation of the test mode.

To enter the test mode, move the toggle switch to off, then press and hold the test button on the control board for 3 seconds. The control board test mode performs the following functions for a 2-minute time period:

- Energizes all control board relays
- Energizes all control board lights

After 2 minutes, the control board will automatically initiate and complete one ice-making cycle, then stop.

Canceling a test cycle:

To cancel a test cycle, press the test button a second time.

Restarting a test cycle:

The test cycle will restart each time the test button is pressed for a 3-second time period.

Diagnosing an Ice Machine that Will Not Run

▲Warning

High (line) voltage is applied to the control board at all times. Removing the control board fuse or pressing the power button will not remove the power supplied to the control board.

1. Verify primary voltage is supplied to ice machine and the fuse/circuit breaker is closed.
2. Verify control board fuse is okay.

NOTE: If any control board lights are on, the fuse is okay.

3. Verify the bin switch functions properly. A defective bin switch can falsely indicate a full bin of ice.
4. Verify toggle switch functions properly. A defective toggle switch may keep the ice machine in the OFF mode. Refer to toggle switch diagnostics when Steps 1 – 3 test good.
5. Be sure Steps 1 – 4 were followed thoroughly. Intermittent problems are not usually related to the control board. Replace control board if toggle switch operation is correct.

Ice Machine Does Not Cycle Into Harvest when the Harvest Float Is Down/Closed

NOTE: The ice machine will make a thick or double slab when a new freeze cycle is started with ice already present on the evaporator.

Two of the most common scenarios are:

- Power is cycled off/on with ice on the evaporator.
- The water curtain/bin switch is opened/closed in the harvest cycle before the ice releases.

Remove all ice from the evaporator before starting diagnostic procedures.

Freeze Time Lock-In Feature

The ice machine control system incorporates a freeze time lock-in feature. This prevents the ice machine from short cycling in and out of harvest. The control board locks the ice machine in the freeze cycle for six minutes. After six minutes a harvest cycle can be initiated. To allow the service technician to initiate a harvest cycle without delay, this feature is not used on the first cycle after moving the toggle switch to OFF and back to ON.

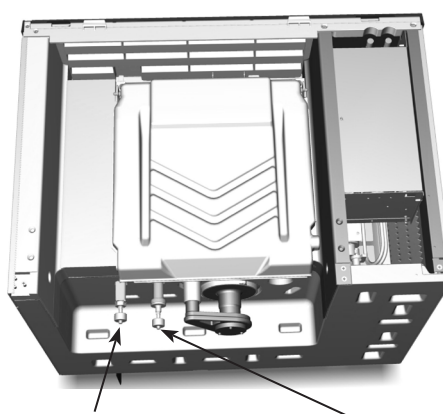

Ice Thickness Float Switch

Harvest Float Switch

Step 1 Disconnect power to the ice machine, remove the electrical panel to allow viewing of the control board lights. Disconnect the harvest float switch wire from the control board and place a jumper on the control board harvest switch terminals.

Step 2 Bypass the freeze time lock-in feature by moving the toggle switch Off/On to cycle the ice machine on. Wait until water flows over the evaporator, then refer to chart.

Result	Correction
10 seconds into the freeze cycle the ice machine cycles from freeze to harvest and the control board harvest light energizes.	The ice thickness float switch, connectors or wiring are causing the malfunction.
The harvest light comes on, but the ice machine remains in the freeze cycle.	The ice machine is in a 6 minute freeze lock - Cycle on/off and retest.
The harvest light stays off and the ice machine remains in freeze.	Replace the control board.

Ice Machine Cycles Into Harvest Before the Harvest Float Is Down/Closed

Step 1 Disconnect power to the ice machine, remove the electrical panel to allow viewing of the control board lights and disconnect the harvest float switch from the control board.

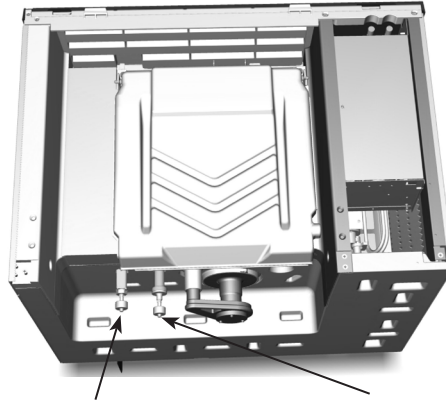

Ice Thickness Float Switch

Harvest Float Switch

Step 2 Reapply power and move the toggle switch to Ice to bypass the freeze time lock-in feature. Wait until water flows over the evaporator, then refer to chart.

Result	Correction
The harvest light does not come on and the ice machine stays in freeze.	The ice thickness float switch, connectors or wiring are causing the malfunction. Refer to float switch diagnostics.
10 seconds into the freeze cycle the ice machine cycles from freeze to harvest and the control board harvest light energizes.	Replace the control board.

Ice Production Check

The amount of ice a machine produces directly relates to the operating water and air temperatures. This means an ice machine with a 70°F (21°C) ambient temperature and 50°F (10°C) water produces more ice than the same ice machine with 90°F (32°C) ambient and 70°F (21°C) water.

1. Determine the ice machine operating conditions:
 Air temp entering condenser: _____°
 Air temp around ice machine: _____°
 Water temp entering sump trough: _____°
2. Refer to the appropriate 24-Hour Ice Production Chart. Use the operating conditions determined in Step 1 to find published 24-Hour Ice Production: _____
 - Times are in minutes.
 Example: 1 min. 15 sec. converts to 1.25 min.
 (15 seconds ÷ 60 seconds = .25 minutes)
 - Weights are in pounds.
 Example: 2 lb. 6 oz. converts to 2.375 lb.
 (6 oz. ÷ 16 oz. = .375 lb.)
3. Perform an ice production check using the formula below.

1.	$\frac{\text{Freeze Time}}{\text{Freeze Time}} + \frac{\text{Harvest Time}}{\text{Harvest Time}} = \frac{\text{Total Cycle Time}}{\text{Total Cycle Time}}$	=	$\frac{\text{Total Cycle Time}}{\text{Total Cycle Time}}$
2.	$\frac{1440}{\text{Minutes in 24 Hrs.}} \div \frac{\text{Total Cycle Time}}{\text{Total Cycle Time}} = \frac{\text{Cycles per Day}}{\text{Cycles per Day}}$	=	$\frac{\text{Cycles per Day}}{\text{Cycles per Day}}$
3.	$\frac{\text{Weight of One Harvest}}{\text{Weight of One Harvest}} \times \frac{\text{Cycles per Day}}{\text{Cycles per Day}} = \frac{\text{Actual 24-Hour Production}}{\text{Actual 24-Hour Production}}$	=	$\frac{\text{Actual 24-Hour Production}}{\text{Actual 24-Hour Production}}$

Weighing the ice is the only 100% accurate check.

4. Compare the results of Step 3 with Step 2. Ice production is normal when these numbers match closely. If they match closely, determine if:
 - Another larger ice machine is required.
 - Relocating the existing equipment to lower the load conditions is required.

Installation/Visual Inspection Checklist

Ice machine is not level

- Level the ice machine

Condenser is dirty

- Clean the condenser

Water filtration is plugged (if used)

- Install a new water filter

Water drains are not run separately and/or are not vented

- Run and vent drains according to the Installation Manual

Water System Checklist

A water-related problem often causes the same symptoms as a refrigeration system component malfunction.

Example: A water dump valve leaking during the freeze cycle, a system low on charge, and a starving TXV have similar symptoms.

Water system problems must be identified and eliminated prior to replacing refrigeration components.

Water area (evaporator) is dirty

- Clean as needed

Water inlet pressure not between 20 and 80 psig (1–5 bar, 138–552 kPa)

- Install a water regulator valve or increase the water pressure

Incoming water temperature is not between 35°F (1.7°C) and 90°F (32.2°C)

- If too hot, check the hot water line check valves in other store equipment

Water filtration is plugged (if used)

- Install a new water filter

Vent tube is not installed on water outlet drain

- See Installation Instructions

Hoses, fittings, etc., are leaking water

- Repair/replace as needed

Water valve is stuck open, closed or is leaking

- Clean/replace as needed

Water is spraying out of the sump trough area

- Stop the water spray

Uneven water flow across the evaporator

- Clean the ice machine

Water is freezing behind the evaporator

- Correct the water flow

Plastic extrusions and gaskets are not secured to the evaporator

- Remount/replace as needed

Ice Formation Pattern

Evaporator ice formation pattern analysis is helpful in ice machine diagnostics.

Analyzing the ice formation pattern alone cannot diagnose an ice machine malfunction. However, when this analysis is used along with the Refrigeration System Operational Analysis Table, it can help diagnose an ice machine malfunction.



Example of Evaporator Tubing Routing

Normal Ice Formation

Ice forms across the entire evaporator surface.

At the beginning of the Freeze cycle, it may appear that more ice is forming on the inlet of the evaporator than at the outlet. At the end of the Freeze cycle, ice formation at the outlet will be close to, or just a bit thinner than, ice formation at the inlet. The dimples in the cubes at the outlet of the evaporator may be more pronounced than those at the inlet. This is normal.

If ice forms uniformly across the evaporator surface, but does not do so in the proper amount of time, this is still considered a normal ice fill pattern.

Extremely Thin at Evaporator Outlet

There is no ice, or a considerable lack of ice formation on the outlet of the evaporator.

Examples: No ice at all at the outlet of the evaporator, but ice forms at the inlet half of the evaporator. Or, the ice at the outlet of the evaporator reaches the correct thickness, but the outlet of the evaporator already has 1/2" to 1" (12.7 mm to 25.4 mm) of ice formation.

Extremely Thin at Evaporator Inlet

There is no ice, or a considerable lack of ice formation at the inlet of the evaporator.

Examples: The ice at the outlet of the evaporator reaches the correct thickness, but there is no ice formation at all at the inlet of the evaporator.

No Ice Formation

The ice machine operates for an extended period, but there is no ice formation at all on the evaporator.

Evaporator Tubing Routing

Routing of the tubing on the back of the evaporator determines the ice fill pattern failure mode. The evaporator outlet tubing does not exit directly at the top of the evaporator, but exits several inches below the top of the evaporator. Extremely Thin at the Evaporator Outlet will first be visible several inches below the top of the evaporator. Extremely Thin at Evaporator Inlet will first be visible at the bottom of the evaporator.

Safety Limits

Safety limits are stored and indicated by the control board. The number of cycles required to stop the ice machine varies for each safety limit.

Safety limits can be reset by cycling the toggle switch Off/On and starting a new ice making cycle.

A safety limit is indicated by a flashing light on the control board.

SAFETY LIMIT 1

If the freeze time reaches 35 minutes, the control board automatically initiates a harvest cycle.

- After 3 consecutive 35 minute cycles, control board light SL#1 light will flash on/off at 1 second intervals.
- If 6 consecutive 35-minute freeze cycles occur, the ice machine stops and the SL#1 light on the control board will be on continuously.

SAFETY LIMIT 2

If the harvest time reaches 3.5 minutes, the control board automatically returns the ice machine to the freeze cycle.

- If three consecutive 3.5 minute harvest cycles occur, the SL#2 light on the control board will flash on/off at 1 second intervals. After 75 consecutive 3.5 minutes harvest cycles, the SL#2 light will be energized continuously.
- If 100 consecutive 3.5 minute harvest cycles occur, the ice machine stops and the SL#2 light on the control board will be on continuously.

SAFETY LIMIT 3

If the harvest float switch hasn't opened for 10 continuous seconds within the first 4 minutes of the freeze cycle, the ice machine stops.

- Safety Limit 3 is bypassed on the initial cycle (manual start or after a full bin/safety limit condition). For all subsequent cycles, the ice machine stops for 30 minutes when the harvest float switch hasn't opened for 10 continuous seconds within the first 4 minutes of the freeze cycle. Control board lights SL#1 and SL#2 will flash on/off at 1 second intervals.
- The ice machine automatically restarts at the end of the 30 minute delay period and stops flashing the control board lights.
- If 100 consecutive failures occur, the ice machine stops and the SL#1 & SL#2 lights flash on/off at 1 second intervals.
- SL#1 & SL#2 will flash 3 times on start-up and automatically erase after 100 normal cycles.

Determining Which Safety Limit Stopped the Ice Machine:

1. Cycle the toggle switch Off.
2. Cycle the toggle switch On to start ice making.
3. Watch the safety limit lights.
 - One will flash corresponding to safety limits 1 or 2.
4. Safety limit 3 is indicated by both SL#1 & SL#2 flashing.

After safety limit indication, the ice machine will restart and run until a safety limit is exceeded again.

Safety Limit Notes

- A continuous run of 100 harvests automatically erases the safety limit code.
- The control board will store and indicate only one safety limit – the last one exceeded.
- If the toggle switch is cycled OFF and then ON prior to reaching the 100-harvest point, the last safety limit exceeded will be indicated.

SAFETY LIMIT CHECKLIST

The following checklists are designed to assist the service technician in analysis. However, because there are many possible external problems, do not limit your diagnosis to only the items listed.

Safety Limit #1

Freeze time exceeds 35 minutes for 6 consecutive freeze cycles.

Possible Cause Checklist

Improper installation

- Refer to “Installation/Visual Inspection Checklist” on page 42

Water System

- Float switch or water escaping water trough
- Low water pressure (20 psig min.)
- High water pressure (80 psig max.)
- High water temperature (90°F/32.2°C max.)
- Clogged water distribution tube
- Dirty/defective water inlet valve
- Defective water pump

Electrical System

- Harvest cycle not initiated electrically
- Contactor not energizing
- Compressor electrically non-operational
- Restricted condenser air flow
- High inlet air temperature (110°F/43.3°C max.)
- Condenser discharge air re-circulation
- Dirty condenser fins
- Defective fan cycling control
- Defective fan motor
- Dirty condenser

Refrigeration System

- Non-OEM components
- Improper refrigerant charge
- Defective compressor
- TXV starving or flooding (check bulb mounting)
- Non-condensable in refrigeration system
- Plugged or restricted high side refrigerant lines or component
- Defective harvest valve

Safety Limit #2

Harvest time exceeds 3.5 minutes for 100 Consecutive harvest cycles.

Possible Cause Checklist

Improper installation

- Refer to “Installation/Visual Inspection Checklist” on page 42

Water System

- Water area (evaporator) dirty
- Dirty/defective water dump valve
- Vent tube not installed on water outlet drain
- Water freezing behind evaporator
- Plastic extrusions and gaskets not securely mounted to the evaporator

Electrical System

- Bin switch defective
- Premature harvest

Refrigeration System

- Non-OEM components
- Improper refrigerant charge
- Defective harvest valve
- TXV flooding (check bulb mounting)
- Defective fan cycling control

Safety Limit 3

The harvest float switch hasn't opened for 10 continuous seconds in the first 4 minutes of the freeze cycle.

Possible Cause Checklist

Improper installation

- Refer to "Installation/Visual Inspection Checklist" on page 42

Water System

- Water dump valve
- Harvest float valve dirty or defective
- Low water pressure (20 psig min.)
- Dirty defective water filter (when used)
- Loss of water from sump area
- Dirty/defective water inlet valve

Electrical System

- Water inlet valve coil defective
- Harvest float valve defective

Analyzing Discharge Pressure

- Determine the ice machine operating conditions:

Air temp. entering condenser _____°

Air temp. around ice machine _____°

Water temp. entering sump trough _____°

- Refer to “Ice Machine Normal Operation Charts” on page 119 for ice machine being checked.

Use the operating conditions determined in Step 1 to find the published normal discharge pressures.

Freeze Cycle _____

Harvest Cycle _____

- Perform an actual discharge pressure check.

	Freeze Cycle PSIG	Harvest Cycle PSIG
Beginning of Cycle	_____	_____
Middle of Cycle	_____	_____
End of Cycle	_____	_____

- Compare the actual discharge pressure (Step 3) with the published discharge pressure (Step 2).

The discharge pressure is normal when the actual pressure falls within the published pressure range for the ice machine’s operating conditions. It is normal for the discharge pressure to be higher at the beginning of the freeze cycle (when load is greatest), then drop throughout the freeze cycle.

DISCHARGE PRESSURE HIGH CHECKLIST

Improper Installation

- Refer to “Installation/Visual Inspection Checklist” on page 42

Condenser Air Flow

- High inlet air temperature
- Condenser discharge air re-circulation
- Dirty condenser fins
- Defective fan cycling control
- Defective fan motor

Improper Refrigerant Charge

- Overcharged
- Non-condensable in system
- Wrong type of refrigerant

Other

- Non-OEM components in system
- High side refrigerant lines/component restricted (before mid-condenser)

FREEZE CYCLE DISCHARGE PRESSURE LOW CHECKLIST

Improper Installation

- Refer to “Installation/Visual Inspection Checklist” on page 42

Improper Refrigerant Charge

- Undercharged
- Wrong type of refrigerant

Other

- Non-OEM components in system
- High side refrigerant lines/component restricted (before mid-condenser)
- Defective fan cycle control

Analyzing Suction Pressure

The suction pressure gradually drops throughout the freeze cycle. The actual suction pressure (and drop rate) changes as the air and water temperature entering the ice machine changes. These variables also determine the freeze cycle times.

To analyze and identify the proper suction pressure drop throughout the freeze cycle, compare the published suction pressure to the published freeze cycle time.

NOTE: Analyze discharge pressure before analyzing suction pressure. High or low discharge pressure may be causing high or low suction pressure.

Procedure

Step																												
<p>1. Determine the ice machine operating conditions.</p> <p><i>Example:</i> <i>Air temp. entering condenser: 90°F/32.2°C</i> <i>Air temp. around ice machine: 80°F/26.7°C</i> <i>Water temp. entering water fill valve: 70°F/21.1°C</i></p>																												
<p>2A. Refer to “Cycle Time” and “Operating Pressure” charts for ice machine model being checked. Using operating conditions from Step 1, determine published freeze cycle time and published freeze cycle suction pressure.</p> <p><i>Example:</i> <i>Published freeze cycle time: 14.8 - 15.9 minutes</i> <i>Published freeze cycle suction pressure: 65 - 26 psig</i></p>																												
<p>2B. Compare the published freeze cycle time and published freeze cycle suction pressure. Develop a chart.</p> <p><i>Example:</i></p> <table border="1"> <thead> <tr> <th colspan="7"><u>Published Freeze Cycle Time (minutes)</u></th> </tr> <tr> <th>1</th> <th>2</th> <th>4</th> <th>7</th> <th>10</th> <th>12</th> <th>14</th> </tr> </thead> <tbody> <tr> <td> </td> <td> </td> <td> </td> <td> </td> <td> </td> <td> </td> <td> </td> </tr> <tr> <td>65</td> <td>55</td> <td>47</td> <td>39</td> <td>34</td> <td>30</td> <td>26</td> </tr> </tbody> </table> <p><u>Published Freeze Cycle Suction Pressure (psig)</u> <i>In the example, the proper suction pressure should be approximately 39 psig at 7 minutes; 30 psig at 12 minutes; etc.</i></p>	<u>Published Freeze Cycle Time (minutes)</u>							1	2	4	7	10	12	14								65	55	47	39	34	30	26
<u>Published Freeze Cycle Time (minutes)</u>																												
1	2	4	7	10	12	14																						
65	55	47	39	34	30	26																						
<p>3. Perform an actual suction pressure check at the beginning, middle and end of the freeze cycle. Note the times at which the readings are taken.</p> <p><i>Example:</i> <i>Manifold gauges were connected to the example ice machine and suction pressure readings taken as follows: _____ PSIG</i> <i>Beginning of freeze cycle: 79 (at 1 min.)</i> <i>Middle of freeze cycle: 48 (at 7 min.)</i> <i>End of freeze cycle: 40 (at 14 min.)</i></p>																												
<p>4. Compare the actual freeze cycle suction pressure (Step 3) to the published freeze cycle time and pressure comparison (Step 2B). Determine if the suction pressure is high, low or acceptable.</p> <p><i>Example:</i> <i>In this example, the suction pressure is considered high throughout the freeze cycle. It should have been:</i> <i>Approximately 65 psig (at 1 minute) – not 79</i> <i>Approximately 39 psig (at 7 minutes) – not 48</i> <i>Approximately 26 psig (at 14 minutes) – not 40</i></p>																												

SUCTION PRESSURE HIGH CHECKLIST

Improper Installation

- Refer to “Installation/Visual Inspection Checklist” on page 42

Discharge Pressure

- Discharge pressure is too high and is affecting suction pressure, refer to “Discharge Pressure High Checklist” on page 51

Improper Refrigerant Charge

- Overcharged
- Wrong type of refrigerant
- Non-condensable in system

Other

- Non-OEM components in system
- Harvest valve leaking
- TXV flooding (check bulb mounting)
- Defective compressor

SUCTION PRESSURE LOW CHECKLIST

Improper Installation

- Refer to “Installation/Visual Inspection Checklist” on page 42

Discharge Pressure

- Discharge pressure is too low, and is affecting suction pressure, refer to “Freeze Cycle Discharge Pressure Low Checklist” on page 51

Improper Refrigerant Charge

- Undercharged
- Wrong type of refrigerant

Other

- Non-OEM components in system
- Improper water supply over evaporator refer to “Water System Checklist” on page 43
- Loss of heat transfer from tubing on back side of evaporator
- Restricted/plugged liquid line drier
- Restricted/plugged tubing in suction side of refrigeration system
- TXV starving

Harvest Valve

General

The harvest valve is an electrically operated valve that opens when energized, and closes when de-energized.

Normal Operation

The valve is de-energized (closed) during the freeze cycle and energized (open) during the harvest cycle. The valve is positioned between the compressor discharge line and the evaporator and performs two functions:

1. Prevents refrigerant from entering the evaporator during the freeze cycle.
The harvest valve is not used during the freeze cycle. The harvest valve is de-energized (closed) preventing refrigerant flow from the discharge line into the evaporator.
2. Allows refrigerant vapor to enter the evaporator in the harvest cycle.
During the harvest cycle, the harvest valve is energized (open) allowing refrigerant gas from the discharge line of the compressor to flow into the evaporator. The heat is absorbed by the evaporator and allows release of the ice slab.

Exact pressures vary according to ambient temperature and ice machine model. Harvest pressures can be found in the Cycle Time/24 Hour Ice Production/ Refrigerant Pressure Charts in this book.

HARVEST VALVE ANALYSIS

The valve can fail in two positions:

- Valve will not open in the harvest cycle.
- Valve remains open during the freeze cycle.

VALVE WILL NOT OPEN IN THE HARVEST CYCLE:

Although the circuit board has initiated a harvest cycle, the evaporator temperature remains unchanged from the freeze cycle.

VALVE REMAINS OPEN IN THE FREEZE CYCLE:

Symptoms of a harvest valve remaining partially open during the freeze cycle can be similar to symptoms of an expansion valve or compressor problem. Symptoms are dependent on the amount of leakage in the freeze cycle.

A small amount of leakage will cause increased freeze times and an ice fill pattern that is “Thin at the Outlet”, but fills in at the end of the cycle.

As the amount of leakage increases, the length of the freeze cycle increases and the amount of ice at the outlet of the evaporator decreases.

Refer to the Parts Manual for proper valve application. If replacement is necessary, use only “original” replacement parts.

Use the following procedure and table to help determine if a harvest valve is remaining partially open during the freeze cycle.

1. Wait five minutes into the freeze cycle.
2. Feel the inlet of the harvest valve(s).

Important

Feeling the harvest valve outlet or across the harvest valve itself will not work for this comparison.

The harvest valve outlet is on the suction side (cool refrigerant). It may be cool enough to touch even if the valve is leaking.

3. Feel the compressor discharge line.

▲Warning

The inlet of the harvest valve and the compressor discharge line could be hot enough to burn your hand. Just touch them momentarily.

4. Compare the temperature of the inlet of the harvest valves to the temperature of the compressor discharge line.

Findings	Comments
<p>The inlet of the harvest valve is cool enough to touch and the compressor discharge line is hot.</p> <p style="text-align: center;">Cool & Hot</p>	<p>This is normal as the discharge line should always be too hot to touch and the harvest valve inlet, although too hot to touch during harvest, should be cool enough to touch after 5 minutes into the freeze cycle.</p>
<p>The inlet of the harvest valve is hot and approaches the temperature of a hot compressor discharge line.</p> <p style="text-align: center;">Hot & Hot</p>	<p>This is an indication something is wrong, as the harvest valve inlet did not cool down during the freeze cycle. If the compressor dome is also entirely hot, the problem is not a harvest valve leaking, but rather something causing the compressor (and the entire ice machine) to get hot.</p>
<p>Both the inlet of the harvest valve and the compressor discharge line are cool enough to touch.</p> <p style="text-align: center;">Cool & Cool</p>	<p>This is an indication something is wrong, causing the compressor discharge line to be cool to the touch. This is not caused by a harvest valve leaking.</p>

5. Record your findings on the table.

Comparing Evaporator Inlet/Outlet Temperatures

The temperatures of the suction lines entering and leaving the evaporator alone cannot diagnose an ice machine. However, comparing these temperatures during the freeze cycle, along with the Refrigeration System Operational Analysis Table, can help diagnose an ice machine malfunction.

The actual temperatures entering and leaving the evaporator vary by model, and change throughout the freeze cycle. This makes documenting the “normal” inlet and outlet temperature readings difficult. The key to the diagnosis lies in the difference between the two temperatures five minutes into the freeze cycle. These temperatures must be within 7°F (4°C) of each other.

Use this procedure to document freeze cycle inlet and outlet temperatures.

1. Use a quality temperature meter, capable of taking temperature readings on curved copper lines.
2. Attach the temperature meter sensing device to the copper lines entering and leaving the evaporator.

Important

Do not simply insert the sensing device under the insulation. It must be attached to and reading the actual temperature of the copper line.

3. Wait five minutes into the freeze cycle.
4. Record the temperatures below and determine the difference between them.

Inlet Temperature	Difference must be within 7°F (4°C) at 5 minutes into the freeze cycle	Outlet Temperature
-------------------	--	--------------------

5. Use this with other information gathered on the Refrigeration System Operational Analysis Table to determine the ice machine malfunction.

Discharge Line Temperature Analysis

GENERAL

Knowing if the discharge line temperature is increasing, decreasing or remaining constant can be an important diagnostic tool. Maximum compressor discharge line temperature on a normally operating ice machine steadily increases throughout the freeze cycle. Comparing the temperatures over several cycles will result in a consistent maximum discharge line temperature.

Ambient air temperatures affect the maximum discharge line temperature.

Higher ambient air temperatures at the condenser = higher discharge line temperatures at the compressor.

Lower ambient air temperatures at the condenser = lower discharge line temperatures at the compressor.

Regardless of ambient temperature, the freeze cycle discharge line temperature will be higher than 150°F (66°C) on a normally operating ice machine.

PROCEDURE

Connect a temperature probe on the compressor discharge line within 6" (15 cm) of the compressor. Observe the discharge line temperature for the last three minutes of the freeze cycle and record the maximum discharge line temperature.

Discharge Line Temperature Above 150°F (66°C) at End of Freeze Cycle:

Ice machines that are operating normally will have consistent maximum discharge line temperatures above 150°F (66°C).

Verify the expansion valve sensing bulb is positioned and secured correctly.

Discharge Line Temperature Below 150°F (66°C) at End of Freeze Cycle:

Ice machines that have a flooding expansion valve will have a maximum discharge line temperature that decreases each cycle.

Verify the expansion valve sensing bulb is 100% insulated and sealed airtight. Condenser air contacting an incorrectly insulated sensing bulb will cause overfeeding of the expansion valve.

Refrigeration Component Diagnostics

All electrical and water related problems must be corrected before these charts will work properly. These tables must be used with charts, checklists and other references to eliminate refrigeration components not listed and external items and problems that will cause good refrigeration components to appear defective.

The tables list four different defects that may affect the ice machine's operation.

NOTE: A low-on-charge ice machine and a starving expansion valve have very similar characteristics and are listed under the same column.

PROCEDURE

Step 1 Complete each item individually in the "Operational Analysis" column.

Enter check marks in the boxes.

Each time the actual findings of an item in the "Operational Analysis" column matches the published findings on the table, enter a check mark.

Example: Freeze cycle suction pressure is determined to be low. Enter a check mark in the "low" box.

Perform the procedures and check all information listed. Each item in this column has supporting reference material.

While analyzing each item separately, you may find an "external problem" causing a good refrigerant component to appear bad. **Correct problems as they are found. If the operational problem is found, it is not necessary to complete the remaining procedures.**

Step 2 Add the check marks listed under each of the four columns. Note the column number with the highest total and proceed to "Final Analysis."

NOTE: If two columns have matching high numbers, a procedure was not performed properly and/or supporting material was not analyzed correctly.

FINAL ANALYSIS

The column with the highest number of check marks identifies the refrigeration problem.

Column 1 – Harvest Valve Leaking

A leaking harvest valve must be replaced.

Column 2 – Low Charge/TXV Starving

Normally, a starving expansion valve only affects the freeze cycle pressures, not the harvest cycle pressures. A low refrigerant charge normally affects both pressures. Verify the ice machine is not low on charge before replacing an expansion valve.

Add refrigerant charge in 2 oz. (57 g) increments as a diagnostic procedure to verify a low charge. (Do not add more than the total charge of refrigerant.) If the problem is corrected, the ice machine is low on charge. Find the refrigerant leak.

The ice machine must operate with the nameplate charge. If the leak cannot be found, proper refrigerant procedures must still be followed. Change the liquid line drier, evacuate the system and weigh in the proper charge.

If the problem is not corrected by adding charge, the expansion valve is faulty.

Column 3 – TXV Flooding

A loose or improperly mounted expansion valve bulb causes the expansion valve to flood. Check bulb mounting, insulation, etc., before changing the valve.

Column 4 – Compressor

Replace the compressor and start components. To receive warranty credit, the compressor ports must be properly sealed by crimping and soldering them closed. Old start components must be returned with the faulty compressor.

Refrigeration Component Diagnostic Chart

Operational Analysis	1	2	3	4
<p>Ice Production</p>	<p>Published 24 hour ice production _____ Calculated (actual) 24 hour ice production _____ NOTE: The ice machine is operating properly if the ice fill pattern is normal and ice production is within 10% of charted capacity.</p>			
<p>Installation and Water System</p>	<p>All installation and water related problems must be corrected before proceeding with chart.</p>			
<p>Ice Formation Pattern</p>	<p>Ice formation is extremely thin on outlet of evaporator -or- No ice formation on entire evaporator</p>	<p>Ice formation extremely thin on outlet of evaporator -or- No ice formation on entire evaporator</p>	<p>Ice formation is normal -or- Ice formation is extremely thin on the bottom of evaporator -or- No ice formation on evaporator</p>	<p>Ice formation is normal -or- No ice formation on entire evaporator</p>
<p>Safety Limits Refer to “Analyzing Safety Limits” to eliminate all non-refrigeration problems.</p>	<p>Stops on safety limit: 1 or 2</p>	<p>Stops on safety limit: 1</p>	<p>Stops on safety limit: 1 or 2</p>	<p>Stops on safety limit: 1</p>
<p>Freeze Cycle Discharge Pressure</p> <p><u>1 minute</u> <u>Middle</u> <u>End</u></p>	<p>If discharge pressure is High or Low, refer to freeze cycle high or low discharge pressure problem checklist to eliminate problems and/or components not listed on this table before proceeding.</p>			

Operational Analysis	1	2	3	4
<p>Freeze Cycle Suction Pressure</p> <p>1 minute Middle End</p>	<p>If suction pressure is High or Low refer to freeze cycle high or low suction pressure problem checklist to eliminate problems and/or components not listed on this table before proceeding.</p>			
	Suction pressure is High	Suction pressure is Low	Suction pressure is High	Suction pressure is High
Harvest Valve	The harvest valve inlet is HOT and The compressor discharge line is HOT	The harvest valve inlet is COOL and The compressor discharge line is HOT	The harvest valve inlet is COOL and The compressor discharge line is COOL	The harvest valve inlet is COOL and The compressor discharge line is HOT
Discharge Line Temp. Record freeze cycle discharge line temp at the end of freeze cycle.	Discharge line temp 150°F (66°C) or higher at the end of freeze cycle	Discharge line temp 150°F (66°C) or higher at the end of freeze cycle	Discharge line temp less than 150°F (66°C) at the end of freeze cycle	Discharge line temp 150°F (66°C) or higher at the end of freeze cycle
Final Analysis Enter total number of boxes checked in each column.	Harvest Valve Leaking	Low On Charge -or- TXV Starving	TXV Flooding	Compressor

THIS PAGE INTENTIONALLY LEFT BLANK

Troubleshooting

PKU0155 Model

Troubleshooting an Ice Machine Will Not Run

▲Warning

High (line) voltage is applied to the control board (terminals #2 and #4) at all times. Removing control board fuse or moving the toggle switch to OFF will not remove the power supplied to the control board.

1. Verify primary voltage is supplied to ice machine and the fuse/circuit breaker is closed.
2. Verify control board fuse is okay.
3. If the bin switch light functions, the fuse is okay.
4. Verify the bin switch functions properly. A defective bin switch can falsely indicate a full bin of ice.
5. Verify ON/OFF/WASH toggle switch functions properly. A defective toggle switch may keep the ice machine in the OFF mode.
6. Verify low DC voltage is properly grounded. Loose DC wire connections may intermittently stop the ice machine.
7. Replace the control board.
8. Be sure Steps 1 – 5 were followed thoroughly. Intermittent problems are not usually related to the control board.

Troubleshooting Ice Thickness Control Circuitry

ICE MACHINE DOES NOT CYCLE INTO HARVEST WHEN WATER CONTACTS THE ICE THICKNESS CONTROL PROBE

Step 1 Bypass the freeze time lock-in feature by moving the ON/OFF/WASH switch to OFF and back to ON. Wait until the water starts to flow over the evaporator.

Step 2 Clip the jumper wire to the ice thickness probe and any cabinet ground.

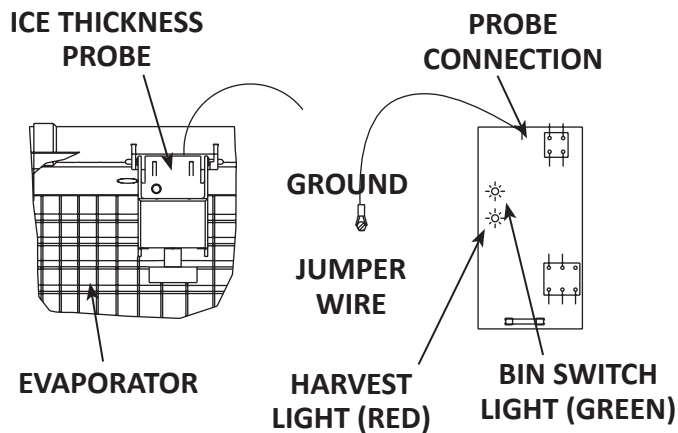

SV1592i

Step 2 Jumper wire connected from probe to ground	
Monitoring Harvest Light	Correction
The harvest light comes on, and 6-10 seconds later, ice machine cycles from freeze to harvest.	The ice thickness control circuitry is functioning properly. Do not change any parts.
The harvest light comes on but the ice machine stays in the freeze sequence.	The ice control circuitry is functioning properly. The ice machine is in a six minute freeze time lock-in. Verify Step 1 of this procedure was followed correctly.
The harvest light does not come on.	Proceed to Step 3.

Step 3 Disconnect the ice thickness probe from the control board terminal. Clip the jumper wire to the terminal on the control board and any cabinet ground. Monitor the harvest light.

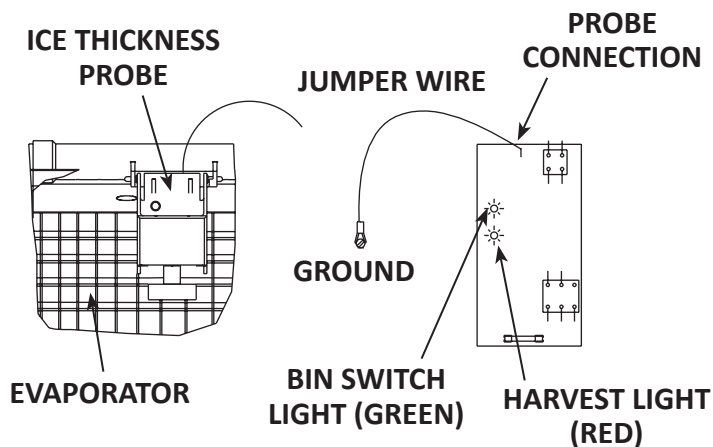

SV1592J

Step 3 Jumper wire connected from control board terminal to ground	
Monitoring Harvest Light	Correction
The harvest light comes on, and 6-10 seconds later, ice machine cycles from freeze to harvest.	The ice thickness probe is causing the malfunction.
The harvest light comes on but the ice machine stays in the freeze sequence.	The control circuitry is functioning properly. The ice machine is in a six-minute freeze time lock-in (verify step 1 of this procedure was followed correctly).
The harvest light does not come on.	The control board is causing the malfunction.

ICE MACHINE CYCLES INTO HARVEST BEFORE WATER CONTACT WITH THE ICE THICKNESS PROBE

Step 1 Bypass the freeze time lock-in feature by moving the ON/OFF/WASH switch to OFF and back to ON. Wait until the water starts to flow over the evaporator, then monitor the harvest light.

Step 2 Disconnect the ice thickness probe from the control board terminal.

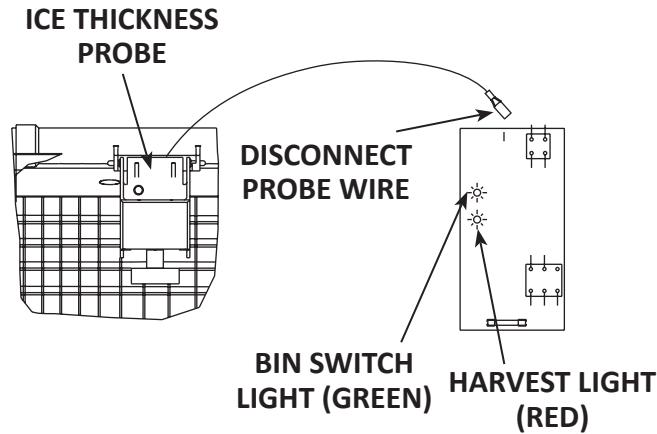

SV1592J_2

Step 2 Disconnect probe from control board terminal	
Monitoring Harvest Light	Correction
The harvest light stays off and the ice machine remains in the freeze sequence.	The ice thickness probe is causing the malfunction. Verify that the ice thickness probe is adjusted correctly.
The harvest light comes on, and 6-10 seconds later, the ice machine cycles from freeze to harvest.	The control board is causing the malfunction.

Ice Production Check

The amount of ice a machine produces directly relates to the operating water and air temperatures. This means an ice machine with a 70°F (21.2°C) ambient temperature and 50°F (10.0°C) water produces more ice than the same ice machine with 90°F (32.2°C) ambient and 70°F (21.2°C) water.

1. Determine the ice machine operating conditions:
 - Air temp entering condenser: _____°
 - Air temp around ice machine: _____°
 - Water temp entering sump trough: _____°
2. Refer to the appropriate 24-Hour Ice Production Chart. Use the operating conditions determined in step 1 to find published 24-Hour Ice Production: _____
 - Times are in minutes.
Example: 1 min. 15 sec. converts to 1.25 min.
(15 seconds ÷ 60 seconds = .25 minutes)
 - Weights are in pounds.
Example: 2 lb. 6 oz. converts to 2.375 lb.
(6 oz. ÷ 16 oz. = .375 lb.)
3. Perform an ice production check using the formula below.

1.	$\frac{\text{Freeze Time}}{\quad} + \frac{\text{Harvest Time}}{\quad} =$	=	$\frac{\text{Total Cycle Time}}{\quad}$
2.	$\frac{1440}{\text{Minutes in 24 Hrs.}} \div \frac{\text{Total Cycle Time}}{\quad} =$	=	$\frac{\text{Cycles per Day}}{\quad}$
3.	$\frac{\text{Weight of One Harvest}}{\quad} \times \frac{\text{Cycles per Day}}{\quad} =$	=	$\frac{\text{Actual 24-Hour Production}}{\quad}$

Weighing the ice is the only 100% accurate check. However, if the ice pattern is normal and the 1/8" (3 mm) thickness is maintained, the ice slab weights listed with the 24-Hour Ice Production Charts may be used.

4. Compare the results of step 3 with step 2. Ice production is normal when these numbers match closely. If they match closely, determine if:
 - Another larger ice machine is required.
 - Relocating the existing equipment to lower the load conditions is required.

Contact the local distributor for information on available options and accessories.

Installation and Visual Inspection Checklist

Ice machine is not level

Level the ice machine

Condenser is dirty

- Clean the condenser

Water filtration is plugged (if used)

- Install a new water filter

Water drains are not run separately and/or are not vented

- Run and vent drains according to the Installation Manual

Water System Checklist

A water-related problem often causes the same symptoms as a refrigeration system component malfunction.

Example: A water dump valve leaking during the freeze cycle, a system low on charge, and a starving TXV have similar symptoms.

Water system problems must be identified and eliminated prior to replacing refrigeration components.

Water area (evaporator) is dirty

- Clean as needed

Water inlet pressure not between 20 and 80 psig (1–5 bar, 138–552 kPa)

- Install a water regulator valve or increase the water pressure

Incoming water temperature is not between 35°F (1.7°C) and 90°F (32.2°C)

- If too hot, check the hot water line check valves in other store equipment

Water filtration is plugged (if used)

- Install a new water filter

Vent tube is not installed on water outlet drain

- See Installation Instructions

Hoses, fittings, etc., are leaking water

- Repair/replace as needed

Water float valve is stuck open or closed

- Clean/replace as needed

Water is spraying out of the sump trough area

- Stop the water spray

Uneven water flow across the evaporator

- Clean the ice machine

Water is freezing behind the evaporator

- Correct the water flow

Plastic extrusions and gaskets are not secured to the evaporator

- Remount/replace as needed

Ice Formation Pattern

Evaporator ice formation pattern analysis is helpful in ice machine diagnostics.

Analyzing the ice formation pattern alone cannot diagnose an ice machine malfunction. However, when this analysis is used along with the Refrigeration System Operational Analysis Table, it can help diagnose an ice machine malfunction.

Any number of problems can cause improper ice formation.

Example: An ice formation that is “extremely thin at the outlet” could be caused by a hot water supply, water leaking out the overflow pipe, a faulty water float valve, a low refrigerant charge, etc.

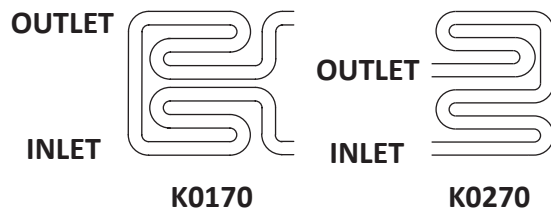

Examples of Evaporator Tubing Routing

Normal Ice Formation

Ice forms across the entire evaporator surface.

At the beginning of the Freeze cycle, it may appear that more ice is forming on the inlet of the evaporator than at the outlet. At the end of the Freeze cycle, ice formation at the outlet will be close to, or just a bit thinner than, ice formation at the inlet. The dimples in the cubes at the outlet of the evaporator may be more pronounced than those at the inlet. This is normal.

If ice forms uniformly across the evaporator surface, but does not do so in the proper amount of time, this is still considered a normal ice fill pattern.

Extremely Thin at Evaporator Outlet

There is no ice, or a considerable lack of ice formation on the outlet of the evaporator.

Examples: No ice at all at the outlet of the evaporator, but ice forms at the inlet half of the evaporator. Or, the ice at the outlet of the evaporator reaches the correct thickness, but the outlet of the evaporator already has 1/2" to 1" (12.7 mm to 25.4 mm) of ice formation.

Possible cause: Water loss, low on refrigerant, starving TXV, hot water supply, faulty float valve, etc.

Extremely Thin at Evaporator Inlet

There is no ice, or a considerable lack of ice formation at the inlet of the evaporator.

Examples: The ice at the outlet of the evaporator reaches the correct thickness, but there is no ice formation at all at the inlet of the evaporator.

Possible cause: Insufficient water flow, flooding TXV, etc.

Spotty Ice Formation

There are small sections on the evaporator where there is no ice formation. This could be a single corner, or a single spot in the middle of the evaporator. This is generally caused by loss of heat transfer from the tubing on the backside of the evaporator.

No Ice Formation

The ice machine operates for an extended period, but there is no ice formation at all on the evaporator.

Possible cause: Water float valve, water pump, starving expansion valve, low refrigerant charge, compressor, etc.

Safety Limit Feature

In addition to the standard safety controls, your Koolaire® ice machine features built-in safety limits that will stop the ice machine if conditions arise which could cause a major component failure.

Before calling for service, re-start the ice machine using the following procedure:

1. Move the ON/OFF/WASH switch to OFF and then back to ON.
2. If the safety limit feature has stopped the ice machine, it will restart after a short delay. Proceed to step 4.
3. If the ice machine does not restart, see “Ice machine does not operate”.
4. Allow the ice machine to run to determine if the condition is reoccurring.
 - A. If the ice machine stops again, the condition has reoccurred. Call for service.
 - B. If the ice machine continues to run, the condition has corrected itself. Allow the ice machine to continue running.

SAFETY LIMITS

In addition to standard safety controls, the control board has two built in safety limit controls which protect the ice machine from major component failures.

SAFETY LIMIT #1

If the freeze time reaches 60 minutes, the control board automatically initiates a harvest cycle. 3 cycles outside the time limit = 1 hour Stand-by Mode.

SAFETY LIMIT #2

If the harvest time reaches 3.5 minutes, the control board automatically returns the ice machine to the freeze cycle. 3 cycles outside the time limit = Safety Limit (must be MANUALLY reset).

SAFETY LIMIT STAND-BY MODE

The first time a safety limit shut down occurs, the ice machine turns off for 60 minutes (Stand-by Mode). The ice machine will then automatically restart to see if the problem reoccurs. During the Stand-by Mode the harvest light will be flashing continuously and a safety limit indication can be viewed. If the same safety limit is reached a second time (the problem has reoccurred), the ice machine will initiate a safety limit shut down and remain off until it is manually restarted. During a safety limit shut down the harvest light will be flashing continuously.

Determining Which Safety Limit Stopped the Ice Machine: When a safety limit condition causes the ice machine to stop, the harvest light on the control board continually flashes on and off. Use the following procedures to determine which safety limit has stopped the ice machine.

1. Move the toggle switch to OFF.
2. Move the toggle switch back to ON.
3. Watch the harvest light. It will flash one or two times, corresponding to safety limits 1 and 2, to indicate which safety limit stopped the ice machine.

After safety limit indication, the ice machine will restart and run until a safety limit is exceeded again.

Safety Limit Notes

- A safety limit indication is completed before the water pump starts. Water contacting the ice thickness probe in the freeze cycle will cause the harvest light to flash. Do not mistake a harvest light flashing in the freeze cycle with a safety limit indication.
- A continuous run of 100 harvests automatically erases the safety limit code.
- The control board will store and indicate only one safety limit – the last one exceeded.
- If the toggle switch is moved to the OFF position and then back to the ON position prior to reaching the 100-harvest point, the last safety limit exceeded will be indicated.
- If the harvest light did not flash prior to the ice machine restarting, then the ice machine did not stop because it exceeded a safety limit.

ANALYZING WHY SAFETY LIMITS MAY STOP THE ICE MACHINE

According to the refrigeration industry, a high percentage of compressor failure is a result of external causes. These can include flooding or starving expansion valves, dirty condensers, water loss to the ice machine, etc. The safety limits protect the ice machine (primarily the compressor) from external failures by stopping ice machine operation before major component damage occurs.

The safety limit system is similar to a high-pressure cutout control. It stops the ice machine, but does not tell what is wrong. The service technician must analyze the system to determine what caused the high-pressure cutout, or a particular safety limit, to stop the ice machine.

The safety limits are designed to stop the ice machine prior to major component failures, most often a minor problem or something external to the ice machine. This may be difficult to diagnose, as many external problems occur intermittently.

Example: An ice machine stops intermittently on safety limit #1 (long freeze times). The problem could be a low ambient temperature at night, a water pressure drop; the water is turned off one night a week, etc.

When a high-pressure cutout or a safety limit stops the ice machine, they are doing what they are supposed to do. That is, stopping the ice machine before a major component failure occurs.

Refrigeration and electrical component failures may also trip a safety limit. Eliminate all electrical components and external causes first. If it appears that the refrigeration system is causing the problem, use the Refrigeration System Operational Analysis Table, along with detailed charts, checklists, and other references to determine the cause.

SAFETY LIMIT CHECKLIST

The following checklists are designed to assist the service technician in analysis. However, because there are many possible external problems, do not limit your diagnosis to only the items listed.

Safety Limit #1

Freeze time exceeds 60 minutes for 6 consecutive freeze cycles.

Possible Cause Checklist

Improper Installation

- Refer to “Installation and Visual Inspection Checklist” on page 70

Water System

- Water Level set too high (water escaping through over flow tube)
- Low water pressure (20 psig min.)
- High water pressure (80 psig max.)
- High water temperature (90°F/32.2°C max.)
- Clogged water distribution tube
- Dirty/defective float valve
- Defective water pump

Electrical System

- Ice thickness probe out of adjustment
- Harvest cycle not initiated electrically
- Compressor relay not energizing
- Compressor electrically non-operational
- High inlet air temperature (110°F/43.3°C max.)
- Defective fan cycling control
- Defective fan motor
- Dirty condenser

Refrigeration System

- Restricted condenser air flow
- Condenser discharge air re-circulation
- Dirty condenser fins
- Non-OEM components
- Improper refrigerant charge
- Defective compressor
- TXV starving or flooding (check bulb mounting)
- Non-condensable in refrigeration system
- Plugged or restricted high side refrigerant lines or component
- Defective harvest valve

Safety Limit #2

Harvest time exceeds 3.5 minutes for 6 Consecutive harvest cycles.

Possible Cause Checklist

Improper Installation

- Refer to “Installation and Visual Inspection Checklist” on page 70

Water System

- Water area (evaporator) dirty
- Dirty/defective water dump valve
- Vent tube not installed on water outlet drain
- Water freezing behind evaporator
- Plastic extrusions and gaskets not securely mounted to the evaporator
- Low water pressure (20 psig min.)
- Loss of water from sump area
- Clogged water distribution tube
- Dirty/defective float valve
- Defective water pump

Electrical System

- Ice thickness probe out of adjustment
- Ice thickness probe dirty
- Bin switch defective
- Premature harvest

Refrigeration System

- Non-OEM components
- Improper refrigerant charge
- Defective harvest valve
- TXV flooding (check bulb mounting)
- Defective fan cycling control

Analyzing Discharge Pressure

- Determine the ice machine operating conditions:

Air temp. entering condenser _____°

Air temp. around ice machine _____°

Water temp. entering sump trough _____°

- Refer to “Ice Machine Normal Operation Charts” on page 119 for ice machine being checked.

Use the operating conditions determined in step 1 to find the published normal discharge pressures.

Freeze Cycle _____

Harvest Cycle _____

- Perform an actual discharge pressure check.

	Freeze Cycle PSIG	Harvest Cycle PSIG
Beginning of Cycle	_____	_____
Middle of Cycle	_____	_____
End of Cycle	_____	_____

- Compare the actual discharge pressure (step 3) with the published discharge pressure (step 2).

The discharge pressure is normal when the actual pressure falls within the published pressure range for the ice machine’s operating conditions. It is normal for the discharge pressure to be higher at the beginning of the freeze cycle (when load is greatest), then drop through out the freeze cycle.

DISCHARGE PRESSURE HIGH CHECKLIST

Improper Installation

- Refer to “Installation and Visual Inspection Checklist” on page 70

Restricted Condenser Air Flow

- High inlet air temperature
- Condenser discharge air re-circulation
- Dirty condenser fins
- Defective fan cycling control
- Defective fan motor

Improper Refrigerant Charge

- Overcharged
- Non-condensable in system
- Wrong type of refrigerant

Other

- Non-OEM components in system
- High side refrigerant lines/component
- Restricted (before mid-condenser)

FREEZE CYCLE DISCHARGE PRESSURE LOW CHECKLIST

Improper Installation

- Refer to “Installation and Visual Inspection Checklist” on page 70

Improper Refrigerant Charge

- Undercharged
- Wrong type of refrigerant

Other

- Non-OEM components in system
- High side refrigerant lines/component restricted (before mid-condenser)
- Defective fan cycle control

Analyzing Suction Pressure

The suction pressure gradually drops throughout the freeze cycle. The actual suction pressure (and drop rate) changes as the air and water temperature entering the ice machine changes. These variables also determine the freeze cycle times.

To analyze and identify the proper suction pressure drop throughout the freeze cycle, compare the published suction pressure to the published freeze cycle time.

NOTE: Analyze discharge pressure before analyzing suction pressure. High or low discharge pressure may be causing high or low suction pressure.

Procedure

Step																												
<p>1. Determine the ice machine operating conditions.</p> <p><i>Example:</i> <i>Air temp. entering condenser: 90°F/32.2°C</i> <i>Air temp. around ice machine: 80°F/26.7°C</i> <i>Water temp. entering water fill valve: 70°F/21.1°C</i></p>																												
<p>2A. Refer to “Cycle Time” and “Operating Pressure” charts for ice machine model being checked. Using operating conditions from Step 1, determine published freeze cycle time and published freeze cycle suction pressure.</p> <p><i>Example:</i> <i>Published freeze cycle time: 14.8 - 15.9 minutes</i> <i>Published freeze cycle suction pressure: 65 - 26 psig</i></p>																												
<p>2B. Compare the published freeze cycle time and published freeze cycle suction pressure. Develop a chart.</p> <p><i>Example:</i></p> <table border="1"> <thead> <tr> <th colspan="7"><u>Published Freeze Cycle Time (minutes)</u></th> </tr> <tr> <th>1</th> <th>2</th> <th>4</th> <th>7</th> <th>10</th> <th>12</th> <th>14</th> </tr> </thead> <tbody> <tr> <td> </td> <td> </td> <td> </td> <td> </td> <td> </td> <td> </td> <td> </td> </tr> <tr> <td>65</td> <td>55</td> <td>47</td> <td>39</td> <td>34</td> <td>30</td> <td>26</td> </tr> </tbody> </table> <p><u>Published Freeze Cycle Suction Pressure (psig)</u> <i>In the example, the proper suction pressure should be approximately 39 psig at 7 minutes; 30 psig at 12 minutes; etc.</i></p>	<u>Published Freeze Cycle Time (minutes)</u>							1	2	4	7	10	12	14								65	55	47	39	34	30	26
<u>Published Freeze Cycle Time (minutes)</u>																												
1	2	4	7	10	12	14																						
65	55	47	39	34	30	26																						
<p>3. Perform an actual suction pressure check at the beginning, middle and end of the freeze cycle. Note the times at which the readings are taken.</p> <p><i>Example:</i> <i>Manifold gauge set was connected to the example ice machine and suction pressure readings taken as follows: _____ PSIG</i> <i>Beginning of freeze cycle: 79 (at 1 min.)</i> <i>Middle of freeze cycle: 48 (at 7 min.)</i> <i>End of freeze cycle: 40 (at 14 min.)</i></p>																												
<p>4. Compare the actual freeze cycle suction pressure (Step 3) to the published freeze cycle time and pressure comparison (Step 2B). Determine if the suction pressure is high, low or acceptable.</p> <p><i>Example:</i> <i>In this example, the suction pressure is considered high throughout the freeze cycle. It should have been:</i> <i>Approximately 65 psig (at 1 minute) – not 79</i> <i>Approximately 39 psig (at 7 minutes) – not 48</i> <i>Approximately 26 psig (at 14 minutes) – not 40</i></p>																												

SUCTION PRESSURE HIGH CHECKLIST

Improper Installation

- Refer to “Installation and Visual Inspection Checklist” on page 70

Discharge Pressure

- Discharge pressure is too high, and is affecting suction pressure, refer to “Discharge Pressure High Checklist” on page 81

Improper Refrigerant Charge

- Overcharged
- Wrong type of refrigerant
- Non-condensable in system

Other

- Non-OEM components in system
- Harvest valve leaking
- TXV flooding (check bulb mounting)
- Defective compressor

SUCTION PRESSURE LOW CHECKLIST

Improper Installation

- Refer to “Installation and Visual Inspection Checklist” on page 70

Discharge Pressure

- Discharge pressure is too low, and is affecting suction pressure, refer to “Freeze Cycle Discharge Pressure Low Checklist” on page 81

Improper Refrigerant Charge

- Undercharged
- Wrong type of refrigerant

Other

- Non-OEM components in system
- Improper water supply over evaporator refer to “Water System Checklist” on page 70
- Loss of heat transfer from tubing on back side of evaporator
- Restricted/plugged liquid line drier
- Restricted/plugged tubing in suction side of refrigeration system
- TXV starving

NOTE: Do not limit your diagnosis to only the items listed in the checklists.

Harvest Valve

General

The harvest valve is an electrically operated valve that opens when energized, and closes when de-energized.

Normal Operation

The valve is de-energized (closed) during the freeze cycle and energized (open) during the harvest cycle. The valve is positioned between the receiver and the evaporator and performs two functions:

1. Prevents refrigerant from entering the evaporator during the freeze cycle.
The harvest valve is not used during the freeze cycle. The harvest valve is de-energized (closed) preventing refrigerant flow from the receiver into the evaporator.
2. Allows refrigerant vapor to enter the evaporator in the harvest cycle.
During the harvest cycle, the harvest valve is energized (open) allowing refrigerant gas from the discharge line of the compressor to flow into the evaporator. The heat is absorbed by the evaporator and allows release of the ice slab.

Exact pressures vary according to ambient temperature and ice machine model. Harvest pressures can be found in the Cycle Time/24 Hour Ice Production/Refrigerant Pressure Charts in this book.

HARVEST VALVE ANALYSIS

The valve can fail in two positions:

- Valve will not open in the harvest cycle.
- Valve remains open during the freeze cycle.

VALVE WILL NOT OPEN IN THE HARVEST CYCLE

Although the circuit board has initiated a harvest cycle, the evaporator temperature remains unchanged from the freeze cycle.

⚠ Caution

Coil must be seated 100% on solenoid to function correctly. Install coil with a twisting motion to properly seat.

VALVE REMAINS OPEN IN THE FREEZE CYCLE:

Symptoms of a harvest valve remaining partially open during the freeze cycle can be similar to symptoms of an expansion valve, float valve or compressor problem. Symptoms are dependent on the amount of leakage in the freeze cycle.

A small amount of leakage will cause increased freeze times and an ice fill pattern that is “Thin at the Outlet”, but fills in at the end of the cycle.

As the amount of leakage increases the length of the freeze cycle increases and the amount of ice at the outlet of the evaporator decreases.

Refer to the Parts Manual for proper valve application. If replacement is necessary, use only “original” replacement parts.

Use the following procedure and table to help determine if a harvest valve is remaining partially open during the freeze cycle.

1. Wait five minutes into the freeze cycle.
2. Feel the inlet of the harvest valve.

Important

Feeling the harvest valve outlet or across the harvest valve itself will not work for this comparison.

The harvest valve outlet is on the suction side (cool refrigerant). It may be cool enough to touch even if the valve is leaking.

3. Feel the compressor discharge line.

▲Warning

The inlet of the harvest valve and the compressor discharge line could be hot enough to burn your hand. Just touch them momentarily.

4. Compare the temperature of the inlet of the harvest valve to the temperature of the compressor discharge line.

Troubleshooting

Findings	Comments
The inlet of the harvest valve is cool enough to touch and the compressor discharge line is hot. Cool & Hot	This is normal as the discharge line should always be too hot to touch and the harvest valve inlet, although too hot to touch during harvest, should be cool enough to touch after 5 minutes into the freeze cycle.
The inlet of the harvest valve is hot and approaches the temperature of a hot compressor discharge line. Hot & Hot	This is an indication something is wrong, as the harvest valve inlet did not cool down during the freeze cycle. If the compressor dome is also entirely hot, the problem is not a harvest valve leaking, but rather something causing the compressor (and the entire ice machine) to get hot.
Both the inlet of the harvest valve and the compressor discharge line are cool enough to touch. Cool & Cool	This is an indication something is wrong, causing the compressor discharge line to be cool to the touch. This is not caused by a harvest valve leaking.

5. Record your findings on the table.

Comparing Evaporator Inlet/Outlet Temperatures

The temperatures of the suction lines entering and leaving the evaporator alone cannot diagnose an ice machine. However, comparing these temperatures during the freeze cycle, along with using the Refrigeration System Operational Analysis Table, can help diagnose an ice machine malfunction.

The actual temperatures entering and leaving the evaporator vary by model, and change throughout the freeze cycle. This makes documenting the “normal” inlet and outlet temperature readings difficult. The key to the diagnosis lies in the difference between the two temperatures five minutes into the freeze cycle. These temperatures must be within 7°F (4°C) of each other.

Use this procedure to document freeze cycle inlet and outlet temperatures.

1. Use a quality temperature meter, capable of taking temperature readings on curved copper lines.
2. Attach the temperature meter sensing device to the copper lines entering and leaving the evaporator.

Important

Do not simply insert the sensing device under the insulation. It must be attached to and reading the actual temperature of the copper line.

3. Wait five minutes into the freeze cycle.
4. Record the temperatures below and determine the difference between them.

Inlet Temperature	Difference must be within 7°F (4°C) at 5 minutes into the freeze cycle	Outlet Temperature
-------------------	--	--------------------

5. Use this with other information gathered on the Refrigeration System Operational Analysis Table to determine the ice machine malfunction.

Discharge Line Temperature

GENERAL

Knowing if the discharge line temperature is increasing, decreasing or remaining constant can be an important diagnostic tool. Maximum compressor discharge line temperature on a normally operating ice machine steadily increases throughout the freeze cycle. Comparing the temperatures over several cycles will result in a consistent maximum discharge line temperature.

Ambient air temperatures affect the maximum discharge line temperature.

Higher ambient air temperatures at the condenser = higher discharge line temperatures at the compressor.

Lower ambient air temperatures at the condenser = lower discharge line temperatures at the compressor.

Regardless of ambient temperature, the freeze cycle discharge line temperature will be higher than 150°F (66°C) on a normally operating ice machine.

PROCEDURE

Connect a temperature probe on the compressor discharge line within 6" (15.2 cm) of the compressor.

Observe the discharge line temperature for the last three minutes of the freeze cycle and record the maximum discharge line temperature.

Discharge Line Temperature Above 150°F (66°C) at End of Freeze Cycle:

Ice machines that are operating normally will have consistent maximum discharge line temperatures above 150°F (66°C).

Verify the expansion valve sensing bulb is positioned and secured correctly.

Discharge Line Temperature Below 150°F (66°C) at End of Freeze Cycle:

Ice machines that have a flooding expansion valve will have a maximum discharge line temperature that decreases each cycle.

Verify the expansion valve sensing bulb is 100% insulated and sealed airtight. Condenser air contacting an incorrectly insulated sensing bulb will cause overfeeding of the expansion valve.

Refrigeration Component Diagnostic Chart

All electrical and water related problems must be corrected before these charts will work properly. These tables must be used with charts, checklists and other references to eliminate refrigeration components not listed and external items and problems that will cause good refrigeration components to appear defective.

The tables list four different defects that may affect the ice machine's operation.

NOTE: A low-on-charge ice machine and a starving expansion valve have very similar characteristics and are listed under the same column.

PROCEDURE

Step 1 Complete each item individually in the "Operational Analysis" column.

Enter check marks in the boxes.

Each time the actual findings of an item in the "Operational Analysis" column matches the published findings on the table, enter a check mark.

Example: Freeze cycle suction pressure is determined to be low. Enter a check mark in the "low" box.

Perform the procedures and check all information listed. Each item in this column has supporting reference material.

While analyzing each item separately, you may find an "external problem" causing a good refrigerant component to appear bad. **Correct problems as they are found. If the operational problem is found, it is not necessary to complete the remaining procedures.**

Step 2 Add the check marks listed under each of the four columns. Note the column number with the highest total and proceed to "Final Analysis."

NOTE: If two columns have matching high numbers, a procedure was not performed properly and/or supporting material was not analyzed correctly.

FINAL ANALYSIS

The column with the highest number of check marks identifies the refrigeration problem.

Column 1 – Harvest Valve Leaking

A leaking harvest valve must be replaced.

Column 2 – Low Charge/TXV Starving

Normally, a starving expansion valve only affects the freeze cycle pressures, not the harvest cycle pressures. A low refrigerant charge normally affects both pressures. Verify the ice machine is not low on charge before replacing an expansion valve.

Add refrigerant charge in 2 oz. (57 g) increments as a diagnostic procedure to verify a low charge. (Do not add more than the total charge of refrigerant). If the problem is corrected, the ice machine is low on charge. Find the refrigerant leak.

The ice machine must operate with the nameplate charge. If the leak cannot be found, proper refrigerant procedures must still be followed. Change the liquid line drier, evacuate the system and weigh in the proper charge.

If the problem is not corrected by adding charge, the expansion valve is faulty.

Column 3 – TXV Flooding

A loose or improperly mounted expansion valve bulb causes the expansion valve to flood. Check bulb mounting, insulation, etc., before changing the valve.

Column 4 – Compressor

Replace the compressor and start components. To receive warranty credit, the compressor ports must be properly sealed by crimping and soldering them closed. Old start components must be returned with the faulty compressor.

REFRIGERATION COMPONENT DIAGNOSTIC CHART PKU0155

Operational Analysis	1	2	3	4
<p>Ice Production</p>	<p>Published 24 hour ice production _____ Calculated (actual) 24 hour ice production _____ NOTE: The ice machine is operating properly if the ice fill pattern is normal and ice production is within 10% of charted capacity.</p>			
<p>Installation and Water System</p>	<p>All installation and water related problems must be corrected before proceeding with chart.</p>			
<p>Ice Formation Pattern</p>	<p>Ice formation is extremely thin on top of evaporator -or- No ice formation on the entire evaporator</p>	<p>Ice formation extremely thin on top of the evaporator -or- No ice formation on entire evaporator</p>	<p>Ice formation is normal -or- Ice formation is extremely thin on the bottom of evaporator -or- no ice formation on evaporator</p>	<p>Ice formation is normal -or- No ice formation on entire evaporator</p>
<p>Safety Limits Refer to “Analyzing Safety Limits” to eliminate all non-refrigeration problems.</p>	<p>Stops on safety limit: 1 or 2</p>	<p>Stops on safety limit: 1</p>	<p>Stops on safety limit: 1 or 2</p>	<p>Stops on safety limit: 1</p>
<p>Freeze Cycle Discharge Pressure</p> <p><u>1 minute</u> <u>Middle</u> <u>End</u> into cycle</p>	<p>If discharge pressure is High or Low, refer to freeze cycle high or low discharge pressure problem checklist to eliminate problems and/or components not listed on this table before proceeding.</p>			

Operational Analysis	1	2	3	4
<p>Freeze Cycle Suction Pressure</p> <p>1 minute Middle End</p>	<p>If suction pressure is High or Low refer to freeze cycle high or low suction pressure problem checklist to eliminate problems and/or components not listed on this table before proceeding.</p>			
	Suction pressure is High	Suction pressure is Low	Suction pressure is High	Suction pressure is High
Harvest Valve	The harvest valve inlet is HOT and The compressor discharge line is HOT	The harvest valve inlet is COOL and The compressor discharge line is HOT	The harvest valve inlet is COOL and The compressor discharge line is COOL	The harvest valve inlet is COOL and The compressor discharge line is HOT
Discharge Line Temp. Record freeze cycle discharge line temp at the end of freeze cycle.	Discharge line temp 150°F (66°C) or higher at the end of freeze cycle	Discharge line temp 150°F (66°C) or higher at the end of freeze cycle	Discharge line temp less than 150°F (66°C) at the end of freeze cycle	Discharge line temp 150°F (66°C) or higher at the end of freeze cycle
Final Analysis Enter total number of boxes checked in each column.	Harvest Valve Leaking	Low On Charge -or- TXV Starving	TXV Flooding	Compressor

ICE QUALITY IS POOR — CUBES ARE SHALLOW, INCOMPLETE OR WHITE

Ice machine is dirty

- Clean and sanitize the ice machine

Water filtration is poor

- Replace the filter

Water softener is working improperly (if applicable)

- Repair the water softener

Poor incoming water quality

- Contact a qualified company to test the quality of the incoming water and make appropriate filter recommendations

Water escaping from sump during freeze cycle

- Check standpipe and drain
- Check for water tracking out of water circuit

FREEZE CYCLE IS LONG, LOW ICE PRODUCTION

Water temperature is too high

- Connect to a cold water supply, verify check valves in faucets and other equipment are functioning correctly

Dirty Condenser

- Clean condenser

High air temperature entering condenser

- Air temperature must not exceed 120°F (39°C)

Water inlet valve filter screen is dirty

- Remove the water inlet valve and clean the filter screen

Water inlet valve stuck open or leaking

- Turn off ice machine, if water continues to enter ice machine, verify water pressure is ok then replace water inlet valve

Water inlet valve is not working

- Water inlet valve must be replaced

Refrigeration problem

- Refer to refrigeration diagnostics

Water escaping from sump during freeze cycle

- Check standpipe and drain
- Check for water tracking out of water circuit

ICE MACHINE RUNS AND NO ICE IS PRODUCED

No water to ice machine

- Correct water supply

Incorrect incoming water pressure

- Water pressure must be 20-80 psi (1.4-5.5 bar)

Excessive mineral buildup

- Clean and sanitize the ice machine

Ambient temperature is too high or low

- Ambient temperature must be between 50°F and 110°F (10°C and 43°C)

Compressor relay inoperable

- No voltage to coil or coil defective
- Defective contacts

Compressor off on overload

- Condenser fan motor defective
- Incorrect flow to water cooled condenser
- Ambient temperature too high
- Condenser blocked
- Faulty start components

THIS PAGE INTENTIONALLY LEFT BLANK

Specifications

Main Fuse

Function

The control board fuse stops ice machine operation if electrical components fail causing high amp draw.

Specifications

- The main fuse is 250 Volt, 3.15 amp.

▲Warning

High (line) voltage is applied to the control board at all times. Removing the control board fuse or cycling the toggle switch Off/On will not remove the power supplied to the control board.

Check Procedure

1. If the curtain light is on with the water curtain closed, the fuse is good.

▲Warning

Disconnect electrical power to the entire ice machine before proceeding.

2. Remove the fuse. Check the resistance across the fuse with an ohmmeter.

Reading	Result
Open (OL)	Replace fuse
Closed (O)	Fuse is good

Bin Switch

Function

Bin switch operation is controlled by the movement of the water curtain. The bin switch has two main functions:

1. Terminating the harvest cycle and returning the ice machine to the freeze cycle.
This occurs when the bin switch is opened and closed again within 30 seconds of opening during the harvest cycle.
2. Automatic ice machine shut-off.
If the storage bin is full at the end of a harvest cycle, the sheet of cubes fails to clear the water curtain and holds it down. After the water curtain is held down for 30 seconds, the ice machine shuts off.
The ice machine remains off until enough ice is removed from the storage bin to allow the sheet of cubes to drop clear of the water curtain. As the water curtain swings back to the operating position, the bin switch closes and the ice machine restarts.

Important

The water curtain must be installed (bin switch closed) to start ice making.

Check Procedure

1. Cycle the toggle switch OFF.
2. Watch the curtain light on the control board.
3. Move the water curtain upward, toward the evaporator. The bin switch must close. The curtain light "on" indicates the bin switch has closed properly.
4. Move the water curtain away from the evaporator. The bin switch must open. The curtain light "off" indicates the bin switch has opened properly.

Ohm Test

1. Disconnect the bin switch wires from the control board.
2. Connect an ohmmeter to the disconnected bin switch.
3. Cycle the bin switch open and closed numerous times by opening and closing the water curtain.

NOTE: To prevent misdiagnosis:

- Always use the water curtain magnet to cycle the switch (a larger or smaller magnet will affect switch operation).
- Watch for consistent readings when the bin switch is cycled open and closed (bin switch failure could be erratic).

Float Switch

Function

Open and close to indicate to the control board the level of water in the water trough.

Specifications

Normally closed, float operated magnetic reed switch.

The float switch contacts are closed in the down position. When water raises the float to the up position the magnet in the float opens the contacts.

Check Procedure

The ice machine uses two float switches.

Ice Thickness Float - Indicates the water level has been reached.

Harvest Float - Indicates a harvest cycle needs to be initiated.

Initial testing can be performed by viewing the control board light(s) while raising and lowering the float. The corresponding control board light must turn on and off when the float is raised and lowered.

Harvest Float Switch:

- A. The light must be on in the up position.
- B. The light must be off in the down position.

Ice Thickness Float Switch:

- A. The light must be off in the down position.
- B. The light must be on in the up position.

Specifications

If the control board light does not respond to the float, proceed with Step 1 below.

1. Disconnect power to the ice machine and pull the float switch and connector through the ice machine base and disconnect.
2. Attach an ohm meter lead to each float switch wire.
3. Place the float in the down position - The float switch must be closed.
4. Place the float in the up position - The float switch must be open.
5. If the float tests good, ohm the interconnecting wires to the control board and inspect connectors.

NOTE: Make adjustments with the ice machine in the off position. Making adjustments during the freeze cycle may produce an initial sheet of ice that is thicker than future cycles.

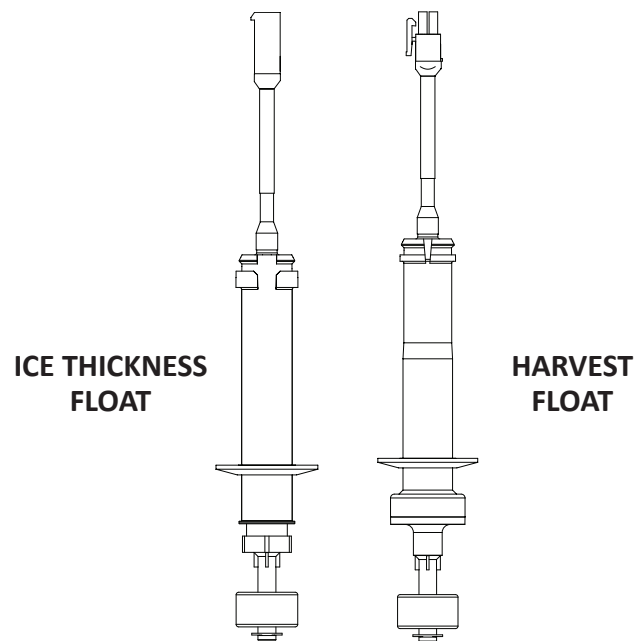

Compressor Electrical Diagnostics

The compressor does not start or will trip repeatedly on overload.

Check Resistance (Ohm) Values

NOTE: Compressor windings can have very low ohm values. Use a properly calibrated meter.

Perform the resistance test after the compressor cools. The compressor dome should be cool enough to touch (below 120°F/49°C) to ensure that the overload is closed and the resistance readings will be accurate.

Single Phase Compressors

1. Disconnect power and remove the wires from the compressor terminals.
2. The resistance values between C and S and between C and R, when added together should equal the resistance value between S and R.
3. If the overload is open, there will be a resistance reading between S and R, and open readings between C and S and between C and R. Allow the compressor to cool, then check the readings again.

Check Motor Windings to Ground

Check continuity between all three terminals and the compressor shell or copper refrigeration line. Scrape metal surface to get good contact. If continuity is present, the compressor windings are grounded and the compressor should be replaced.

To determine if the compressor is seized, check the amp draw while the compressor is trying to start.

Compressor Drawing Locked Rotor

The two likely causes of this are:

- Defective starting component
- Mechanically seized compressor

To determine which you have:

1. Install high and low side gauge.
2. Try to start the compressor.
3. Watch the pressures closely.
 - If the pressures do not move, the compressor is seized. Replace the compressor.
 - If the pressures move, the compressor is turning slowly and is not seized. Check the start components.

Compressor Drawing High Amps

The continuous amperage draw on start-up should not be near the maximum fuse size indicated on the serial tag.

The wiring must be correctly sized to minimize voltage drop at compressor start-up. The voltage when the compressor is trying to start must be within $\pm 10\%$ of the nameplate voltage.

PTCR

The PTCR allows current to flow through the start winding at compressor startup. Current flow heats the ceramic discs in the PTCR. The electrical resistance increases with temperature and stops all except a trickle of current flow through the start winding. The small flow of current keeps the PTCR hot (260°F/127°C) and the start winding out of the circuit.

The PTCR must be cooled before attempting to start the compressor, otherwise the PTCR will heat up too quickly and stop current flow through the start winding before the compressor motor reaches full speed.

▲Warning

Disconnect electrical power to the entire ice machine at the building electrical disconnect box before proceeding.

NOTE: If a PTCR is dropped internal damage can occur to the ceramic PTCR discs. The ceramic disc can chip and cause arcing which leads to PTCR failure. Since there is no way to open the PTCR in order to determine if the ceramic disc is chipped or not, it must be discarded when dropped.

PTCR Operation Check

1. Visually inspect the PTCR. Check for signs of physical damage.

NOTE: The PTCR case temperature may reach 210°F (100°C) while the compressor is running. This is normal. Do not change a PTCR just because it is hot.

2. Wait at least 10 minutes for the PTCR to cool to room temperature.

3. Remove the PTCR from the ice machine.

4. Measure the resistance of the PTCR as shown. The resistance reading must be between:

Model	Ohm Value	Amp
PKM0335/PKM0425/PKM0535	10.5 to 19.5	12

Measure Resistance at Ends

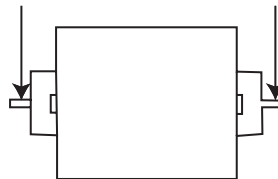

Two Terminal PTCR

Fan Cycle Control

Function

Cycles the fan motor on and off to maintain proper operating discharge pressure.

The fan cycle control closes on an increase, and opens on a decrease in discharge pressure.

Specifications

Model	Cut-In (Close)	Cut-Out (Open)
PKM0335/PKM0425/PKM0535	335 psig ±5 2310 kPa ±5	275 psig ±5 1896 kPa ±5

Check Procedure

Disconnect electrical power to the ice machine at the electrical service disconnect.

Verify fan motor windings are not open or grounded, and fan spins freely.

Connect manifold gauge to ice machine.

Hook voltmeter in parallel across the fan cycle control, leaving wires attached.

Reconnect electrical power to the ice machine and Cycle the toggle switch On.

Wait until water flows over the evaporator then refer to chart below.

System Pressure:	Reading Should Be:	Fan Should Be:
above cut-in	0 volts	running
below cut-out	line voltage	off

High Pressure Cutout (HPCO) Control

Function

Stops the ice machine if subjected to excessive high-side pressure.

The HPCO control is normally closed, and opens on a rise in discharge pressure.

Specifications

Cut-out: 600 psig \pm 10 / 4137 kPa \pm 10

Cut-in: 450 psig \pm 10 / 3103 kPa \pm 10

(Must be below 450 psig / 3103 kPa to reset).

Check Procedure

1. Move toggle switch to OFF.
2. Connect manifold gauge.
3. Hook voltmeter in parallel across the HPCO, leaving wires attached.
4. On water-cooled models, close the water service valve to the water condenser inlet. On self-contained air-cooled models, disconnect the fan motor.
5. Move toggle switch to ON.
6. No water or air flowing through the condenser will cause the HPCO control to open because of excessive pressure. Watch the pressure gauge and record the cut-out pressure.

▲Warning

If discharge pressure exceeds 600 psig - 4137 kPa and the HPCO control does not cut out, cycle the toggle switch Off to stop ice machine operation.

Replace the HPCO control if it:

- Will not reset (below 450 psig - 3103 kPa)
- Does not open at the specified cut-out point

Refrigerant Recovery/Evacuation

DEFINITIONS

Recover

To remove refrigerant, in any condition, from a system and store it in an external container, without necessarily testing or processing it in any way.

Recycle

To clean refrigerant for re-use by oil separation and single or multiple passes through devices, such as replaceable core filter-driers, which reduce moisture, acidity and particulate matter. This term usually applies to procedures implemented at the field job site or at a local service shop.

Reclaim

To reprocess refrigerant to new product specifications (see below) by means which may include distillation. A chemical analysis of the refrigerant is required after processing to be sure that product specifications are met. This term usually implies the use of processes and procedures available only at a reprocessing or manufacturing facility.

Chemical analysis is the key requirement in this definition. Regardless of the purity levels reached by a reprocessing method, refrigerant is not considered “reclaimed” unless it has been chemically analyzed and meets ARI Standard 700 (latest edition).

New Product Specifications

This means ARI Standard 700 (latest edition). Chemical analysis is required to assure that this standard is met.

REFRIGERANT RE-USE POLICY

Proper handling, re-use, and disposal of refrigerants during service procedures require recapturing refrigerants, not venting them to the atmosphere.

It is not necessary, in or out of warranty, to reduce or compromise the quality and reliability of your customers' products to achieve this.

Important

Koolaire assumes no responsibility for use of contaminated refrigerant. Damage resulting from the use of contaminated, recovered, or recycled refrigerant is the sole responsibility of the servicing company.

1. New Refrigerant
 - Must be of original nameplate type.
2. Reclaimed Refrigerant
 - Must be of original nameplate type.
 - Must meet ARI Standard 700 (latest edition) specifications.
3. Recovered or Recycled Refrigerant
 - Must be recovered or recycled in accordance with current local, state and federal laws.
 - Must be recovered from and re-used in the same product. Re-use of recovered or recycled refrigerant from other products is not approved.
 - Recycling equipment must be certified to ARI Standard 740 (latest edition) and be maintained to consistently meet this standard.

4. Recovered refrigerant must come from a “contaminant-free” system. To decide whether the system is contaminant free, consider:
 - Type(s) of previous failure(s)
 - Whether the system was cleaned, evacuated and recharged properly following failure(s)
 - Whether the system has been contaminated by this failure
 - Compressor motor burnouts and improper past service prevent refrigerant re-use.
 - Refer to “Determining Severity of Contamination” on page 113 to test for contamination.
5. “Substitute” or “Alternative” Refrigerant
 - Must use only approved alternative refrigerants.
 - Must follow published conversion procedures.

RECOVERY AND RECHARGING PROCEDURES

Do not purge refrigerant to the atmosphere. Capture refrigerant using recovery equipment. Follow the manufacturer's recommendations.

Important

No responsibility is assumed for the use of contaminated refrigerant. Damage resulting from the use of contaminated refrigerant is the sole responsibility of the servicing company.

Important

Replace the liquid line drier before evacuating and recharging. Use only an O.E.M. liquid line filter drier to prevent voiding the warranty.

CONNECTIONS

1. Suction side of the compressor through the suction service valve.
2. Discharge side of the compressor through the discharge service valve.
3. Liquid side through the liquid line drier.

SELF-CONTAINED RECOVERY/EVACUATION

1. Cycle the toggle switch Off.
2. Install manifold gauge, scale and recovery unit or two-stage vacuum pump and open high, low and charging ports.
3. Perform recovery or evacuation:
 - A. Recovery: Operate the recovery unit as directed by the manufacturer's instructions.
 - B. Evacuation prior to recharging: Pull the system down to 500 microns. Then, allow the pump to run for an additional half hour. Turn off the pump and perform a standing vacuum leak check.
4. Follow the Charging Procedures.

CHARGING PROCEDURES

Important

The charge is critical on this equipment. Use a scale to ensure the proper charge is installed.

1. Cycle the toggle switch Off.
2. Isolate the vacuum pump valve, low side and high side access valves from the refrigeration system. The refrigerant charging access valve remains open.
3. Open the high side manifold gauge valve.
4. Open the refrigerant cylinder and add the proper refrigerant charge (shown on nameplate) through the liquid line drier.

⚠ Caution

Damage may occur when charging liquid into the front discharge line access port.

Replacement driers have a Schrader valve built into the inlet of the drier. Filter driers without an access port must be replaced with the current OEM part before recharging the ice machine. All Liquid refrigerant must be added through the liquid line drier access port.

5. Let the system “settle” for 2 to 3 minutes.
6. Cycle the toggle switch On.

NOTE: Manifold gauge set must be removed properly to ensure that no refrigerant contamination or loss occurs.

7. Make sure that all of the vapor in the charging hoses is drawn into the ice machine before disconnecting the charging hoses.
 - A. Run the ice machine in freeze cycle.
 - B. Remove the high side low loss fitting from the liquid line filter drier.
 - C. Open the high and low side valves on the manifold gauge set. Any refrigerant in the lines will be pulled into the low side of the system.
 - D. Allow the pressures to equalize while the ice machine is in the freeze cycle.
 - E. Remove the hoses from the ice machine and install the caps.

SYSTEM CONTAMINATION CLEANUP

This section describes the basic requirements for restoring contaminated systems to reliable service.

Important

No responsibility is assumed for the use of contaminated refrigerant. Damage resulting from the use of contaminated refrigerant is the sole responsibility of the servicing company.

DETERMINING SEVERITY OF CONTAMINATION

System contamination is generally caused by either moisture or residue from compressor burnout entering the refrigeration system.

Inspection of the refrigerant usually provides the first indication of system contamination. Obvious moisture or an acrid odor in the refrigerant indicates contamination.

If harmful levels of contamination are suspected, perform the following procedure.

1. Remove the refrigerant charge from the ice machine.
2. Remove the compressor from the system.
3. Check the odor and appearance of the oil.
4. Inspect open suction and discharge lines at the compressor for burnout deposits.
5. If no signs of contamination are present, perform an acid oil test to determine the type of cleanup required.

Contamination/Cleanup Chart	
Symptoms/Findings	Required Cleanup Procedure
No symptoms or suspicion of contamination	Normal evacuation/recharging procedure
Moisture/Air Contamination symptoms Refrigeration system open to atmosphere for longer than 15 minutes Refrigeration test kit and/or acid oil test shows contamination No burnout deposits in open compressor lines	Mild contamination cleanup procedure
Mild Compressor Burnout symptoms Oil appears clean but smells acrid Refrigeration test kit or acid oil test shows harmful acid content No burnout deposits in open compressor lines	Mild contamination cleanup procedure
Severe Compressor Burnout symptoms Oil is discolored, acidic, and smells acrid Burnout deposits found in the compressor, lines, and other components	Severe contamination cleanup procedure

CLEANUP PROCEDURE

Mild System Contamination

1. Replace any failed components.
2. If the compressor is good, change the oil.
3. Replace the liquid line drier.

NOTE: If the contamination is from moisture, use heat lamps during evacuation. Position them at the compressor, condenser and evaporator prior to evacuation. Do not position heat lamps too close to plastic components, or they may melt or warp.

4. Follow the normal evacuation procedure, except replace the evacuation step with the following:
 - A. Pull vacuum to 1000 microns. Break the vacuum with dry nitrogen and sweep the system. Pressurize to a minimum of 5 psig.
 - B. Pull vacuum to 500 microns. Break the vacuum with dry nitrogen and sweep the system. Pressurize to a minimum of 5 psig.
 - C. Change the vacuum pump oil.
 - D. Pull vacuum to 500 microns. Run the vacuum pump for 1/2 hour on self-contained models, 1 hour on remotes.

NOTE: You may perform a pressure test as a preliminary leak check. You should use an electronic leak detector after system charging to be sure there are no leaks.

5. Charge the system with the proper refrigerant to the nameplate charge.
6. Operate the ice machine.

SEVERE SYSTEM CONTAMINATION CLEANUP PROCEDURE

1. Remove the refrigerant charge.
2. Remove the compressor and inspect the refrigeration lines. If burnout deposits are found, install a new harvest valve, replace the manifold strainer, TXV and harvest pressure regulating valve.
3. Wipe away any burnout deposits from suction and discharge lines at compressor.
4. Sweep through the open system with dry nitrogen.
5. Install a new compressor and new start components.
6. Install suction line filter-drier in front of compressor.
7. Install an access valve at the inlet of the suction line drier.
8. Install a new liquid line drier.
9. Follow the normal evacuation procedure, except replace the evacuation step with the following:
 - A. Pull vacuum to 1000 microns. Break the vacuum with dry nitrogen and sweep the system. Pressurize to a minimum of 5 psig.
 - B. Change the vacuum pump oil.
 - C. Pull vacuum to 500 microns. Break the vacuum with dry nitrogen and sweep the system. Pressurize to a minimum of 5 psig.
 - D. Change the vacuum pump oil.
 - E. Pull vacuum to 500 microns. Run the vacuum pump for 1 additional hour.

NOTE: You may perform a standing vacuum test to make a preliminary leak check. You should use an electronic leak detector after system charging to be sure there are no leaks.

10. Charge the system with the proper refrigerant to the nameplate charge.
11. Operate the ice machine for one hour. Then, check the pressure drop across the suction line filter-drier.
 - A. If the pressure drop is less than 1 psig the filter-drier should be adequate for complete cleanup.
 - B. If the pressure drop exceeds 1 psig, change the suction line filter-drier and the liquid line drier. Repeat until the pressure drop is acceptable.
12. Operate the ice machine for 48 – 72 hours. Replace the suction line and liquid line drier if necessary.
13. Follow normal evacuation procedures.

LIQUID LINE FILTER DRIERS

The filter-driers used on these ice machines have an access fitting for charging with refrigerant. The drier also has dirt-retaining filtration, with fiberglass filters on both the inlet and outlet ends. This is very important because ice machines have a back-flushing action that takes place during every Harvest cycle.

The size of the filter-drier is important as is high moisture and acid removal capability. The refrigerant charge is critical. Using an improperly sized filter-drier will cause the ice machine to be improperly charged with refrigerant.

Important

Driers are covered as a warranty part. The drier must be replaced any time the system is opened for repairs.

REPLACING PRESSURE CONTROLS WITHOUT REMOVING REFRIGERANT CHARGE

This procedure reduces repair time and cost. Use it when any of the following components require replacement, and the refrigeration system is operational and leak-free.

- Fan cycle control
 - High pressure cut-out control
 - High side access valve
 - Low side access valve
1. Disconnect power to the ice machine.
 2. Follow all manufacturers' instructions supplied with the pinch-off tool. Position the pinch-off tool around the tubing as far from the pressure control as feasible. (See the figure on next page.) Clamp down on the tubing until the pinch-off is complete.

▲Warning

Do not unsolder a defective component. Cut it out of the system. Do not remove the pinch-off tool until the new component is securely in place.

3. Cut the tubing of the defective component with a small tubing cutter.
4. Solder the replacement component in place. Allow the solder joint to cool.
5. Remove the pinch-off tool.
6. Re-round the tubing. Position the flattened tubing in the proper hole in the pinch off tool. Tighten the wing nuts until the block is tight and the tubing is rounded.

NOTE: The pressure controls will operate normally once the tubing is re-rounded. Tubing may not re-round 100%.

Refrigerant Amount

NOTE: All models charged with R410A refrigerant.

Nameplate information overrides all data in this chart.

Model	Air-Cooled
PKU0155	14 oz - 397 g
PKM0335	15 oz - 425 g
PKM0425	16 oz - 454 g
PKM0535	18 oz - 510 g

Ice Machine Normal Operation Charts

These charts are used as guidelines to verify correct ice machine operation.

Accurate collection of data is essential to obtain the correct diagnosis.

- Production and cycle times are for dice cube - Half dice cube cycle times can be 1-2 minutes faster depending on model and ambient temperature.
- Ice production checks that are within 10% of the chart are considered normal. This is due to variances in water and air temperature. Actual temperatures will seldom match the chart exactly.
- Refer to “Operational Analysis Chart” for the list of data that must be collected for refrigeration diagnostics.
- Zero out manifold gauge set before obtaining pressure readings to avoid mis-diagnosis.
- Discharge and suction pressure are highest at the beginning of the cycle. Suction pressure will drop throughout the cycle. Verify the pressures are within the range indicated.
- Record beginning of freeze cycle suction pressure one minute after the water pump energizes.

Specifications

PKU0155 SELF CONTAINED ICE MACHINE

NOTE: These characteristics may vary depending on operating conditions.

CYCLE TIMES

Freeze Time + Harvest Time = Total Cycle Time

Air Temp. Entering Condenser °F/°C	Freeze Time			Harvest Time
	Water Temperature °F/°C			
	50/10	70/21	90/32	
70/21	19.8-22.5	21.2-24.0	26.6-30.2	1.0-2.5
80/27	21.2-24.0	22.7-25.8	29.1-32.9	
90/32	23.6-26.8	26.6-30.2	30.4-34.5	
100/38	27.8-31.5	32.0-36.2	37.5-42.5	
110/43	35.5-40.2	42.4-48.0	52.6-59.4	

Times in minutes

24 HOUR ICE PRODUCTION

Air Temp. Entering Condenser °F/°C	Water Temperature °F/°C		
	50/10	70/21	90/32
70/21	165	155	125
80/27	155	145	115
90/32	140	125	110
100/38	120	105	90
110/43	95	80	65

Based on average ice slab weight of 2.44 – 2.75 lb (1.11 – 1.25 kg)

Regular cube derate is 7%.

OPERATING PRESSURES

Air Temp. Entering Condenser °F/°C	Freeze Cycle		Harvest Cycle	
	Discharge Pressure PSIG	Suction Pressure PSIG	Discharge Pressure PSIG	Suction Pressure PSIG
50/10	220-280	60-38	150-170	90-110
70/21	220-280	60-38	150-170	95-115
80/27	240-290	70-38	160-190	100-120
90/32	280-330	75-38	180-210	160-140
100/38	310-380	85-41	200-230	120-160
110/43	315-390	90-41	200-240	140-170

Suction pressure drops gradually throughout the freeze cycle.

PKM0335 MODULAR ICE MACHINE

NOTE: These characteristics may vary depending on operating conditions.

CYCLE TIMES

Freeze Time + Harvest Time = Total Cycle Time

Air Temp. Entering Condenser °F/°C	Freeze Time			Harvest Time
	Water Temperature °F/°C			
	50/10	70/21	90/32	
70/21	13.3-15.5	16.0-18.6	18.1-21.0	1.0-2.5
80/27	15.7-18.2	18.1-21.0	19.8-22.9	
90/32	17.3-20.1	19.3-22.4	21.8-25.2	
100/38	19.3-22.4	21.3-24.6	23.6-27.3	
110/43	21.8-25.2	23.0-26.6	25.7-29.7	

Times in minutes

24 HOUR ICE PRODUCTION

Air Temp. Entering Condenser °F/°C	Water Temperature °F/°C		
	50/10	70/21	90/32
70/21	330	280	250
80/27	285	250	230
90/32	260	230	210
100/38	235	215	195
110/43	210	200	180

Based on average ice slab weight of 3.40 – 3.90 lb (1.54 – 1.77 kg)

230/50/1 production is approximately 12% lower than 230/60/1.

OPERATING PRESSURES

Air Temp. Entering Condenser °F/°C	Freeze Cycle		Harvest Cycle	
	Discharge Pressure PSIG	Suction Pressure PSIG	Discharge Pressure PSIG	Suction Pressure PSIG
50/10	300-335	70-38	160-180	150-175
70/21	310-340	75-40	180-200	150-175
80/27	315-360	80-42	185-210	150-175
90/32	320-375	90-44	190-215	150-175
100/38	420-510	100-49	300-330	200-250
110/43	450-540	120-52	355-370	270-290

Suction pressure drops gradually throughout the freeze cycle.

Specifications

PKM0425 MODULAR ICE MACHINE

NOTE: These characteristics may vary depending on operating conditions.

CYCLE TIMES

Freeze Time + Harvest Time = Total Cycle Time

Air Temp. Entering Condenser °F/°C	Freeze Time			Harvest Time
	Water Temperature °F/°C			
	50/10	70/21	90/32	
70/21	11.7-13.7	12.5-14.5	13.6-15.8	1.0-2.5
80/27	12.9-15.0	13.8-16.1	15.4-17.9	
90/32	14.0-16.3	14.6-16.9	16.6-19.3	
100/38	15.7-18.2	17.0-19.7	18.1-21.0	
110/43	17.7-20.5	18.9-21.9	20.3-23.5	

Times in minutes

24 HOUR ICE PRODUCTION

Air Temp. Entering Condenser °F/°C	Water Temperature °F/°C		
	50/10	70/21	90/32
70/21	370	350	325
80/27	340	320	290
90/32	315	305	270
100/38	285	265	250
110/43	255	240	225

Based on average ice slab weight of 3.40 – 3.90 lb (1.54 – 1.77 kg)
230/50/1 production is approximately 12% lower than 230/60/1.

OPERATING PRESSURES

Air Temp. Entering Condenser °F/°C	Freeze Cycle		Harvest Cycle	
	Discharge Pressure PSIG	Suction Pressure PSIG	Discharge Pressure PSIG	Suction Pressure PSIG
50/10	275-360	60-31	180-220	130-160
70/21	290-380	65-32	200-220	140-160
80/27	300-390	65-33	215-235	150-170
90/32	330-400	70-34	235-245	160-180
100/38	400-500	80-34	355-370	240-270
110/43	430-520	95-34	370-375	255-275

Suction pressure drops gradually throughout the freeze cycle.

PKM0535 MODULAR ICE MACHINE

NOTE: These characteristics may vary depending on operating conditions.

CYCLE TIMES

Freeze Time + Harvest Time = Total Cycle Time

Air Temp. Entering Condenser °F/°C	Freeze Time			Harvest Time
	Water Temperature °F/°C			
	50/10	70/21	90/32	
70/21	10.0-11.8	12.5-14.6	13.4-15.6	1.0-2.5
80/27	11.7-13.7	12.6-14.8	14.3-16.7	
90/32	12.6-14.8	15.5-17.7	15.5-18.0	
100/38	13.9-16.3	15.5-18.0	16.8-19.5	
110/43	14.8-17.2	16.8-19.5	18.3-21.3	

Times in minutes

24 HOUR ICE PRODUCTION

Air Temp. Entering Condenser °F/°C	Water Temperature °F/°C		
	50/10	70/21	90/32
70/21	515	425	400
80/27	450	420	375
90/32	420	400	350
100/38	385	350	325
110/43	365	325	300

Based on average ice slab weight of 4.125 – 4.75 lb (1.87 – 2.15 kg)

230/50/1 production is approximately 12% lower than 230/60/1.

OPERATING PRESSURES

Air Temp. Entering Condenser °F/°C	Freeze Cycle		Harvest Cycle	
	Discharge Pressure PSIG	Suction Pressure PSIG	Discharge Pressure PSIG	Suction Pressure PSIG
50/10	260-325	60-36	140-175	100-120
70/21	270-340	65-37	150-185	105-130
80/27	275-380	65-37	165-200	110-150
90/32	340-400	75-38	190-220	130-160
100/38	380-500	80-42	280-320	180-235
110/43	440-520	80-44	290-330	185-240

Suction pressure drops gradually throughout the freeze cycle.

Wiring Diagram

▲Warning

Always disconnect power before working on electrical circuitry.

Wiring Diagram Legend

The following symbols are used on all of the wiring diagrams:

- * Internal Compressor Overload
(Some models have external compressor overloads)
- ** Fan Motor Run Capacitor
(Some models do not incorporate fan motor run capacitor)
- () Wire Number Designation
(The number is marked at each end of the wire)
- >>— Multi-pin Connection
(Electrical Box Side) —>
(Compressor Compartment Side) >—

PKU0155 WIRING DIAGRAM

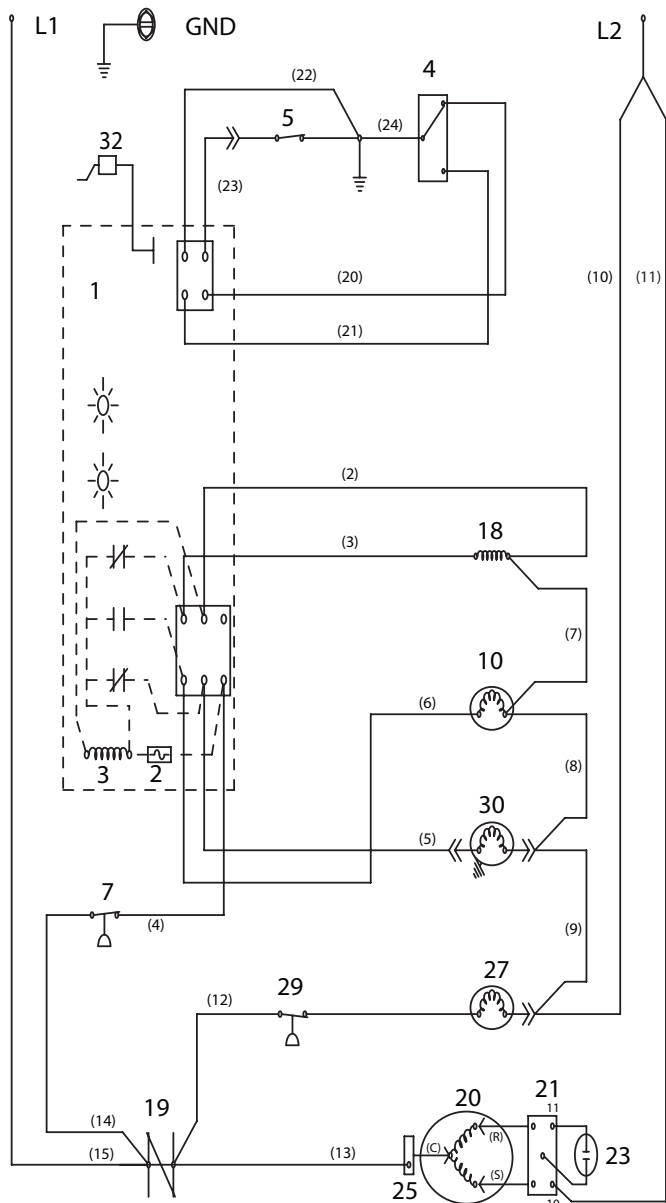

PKU0155

1	Control Board
2	Fuse
3	Transformer
4	On/Off /Clean Switch
5	Bin Switch
6	Bin Thermostat
7	High Pressure Cut Out
10	Harvest Solenoid Valve
18	Contactor Coil
19	Contactor Contacts
20	Compressor
21	Compressor Relay
23	Compressor Start Capacitor
25	Compressor Overload
27	Condenser Fan Motor
29	Fan Cycle Control
30	Water Pump
32	Ice Thickness Control

PKM0335/PKM0425/PKM0535 WIRING DIAGRAM

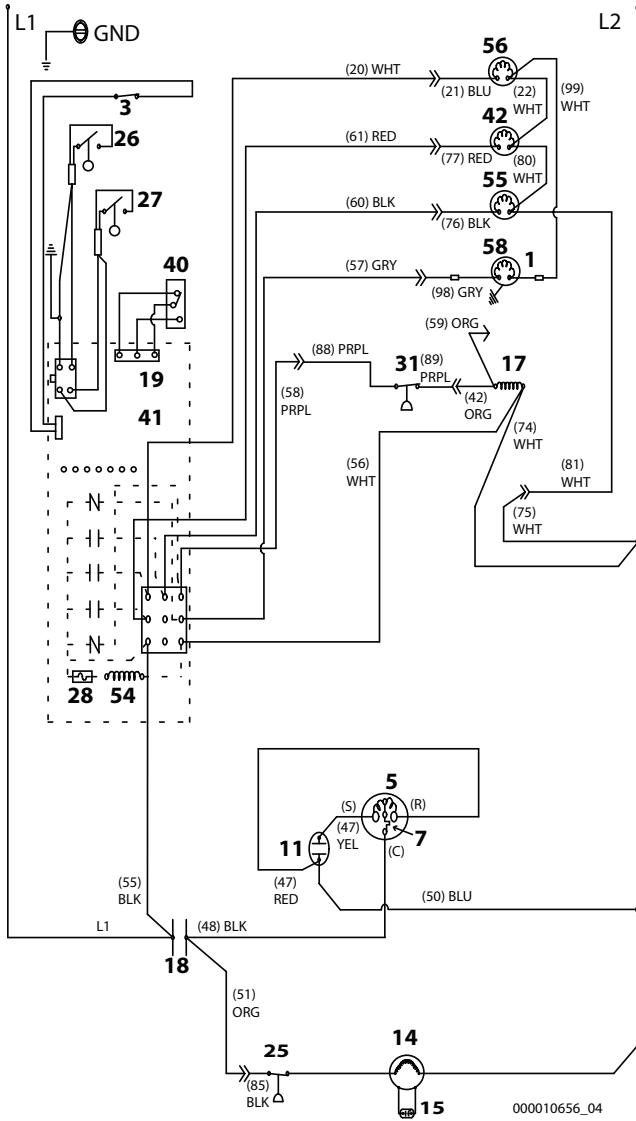

PKM0335/PKM0425/PKM0535

Number	Component
3	Bin Switch
5	Compressor
7	Compressor Overload
11	Compressor Run Capacitor
14	Condenser Fan Motor
15	Condenser Fan Motor Run Capacitor
17	Contacting Coil
18	Contacting Contacts
19	Control Board
25	Fan Cycle Control
26	Harvest Float Switch
27	Water Level Float Switch
28	Fuse
31	High Pressure Cutout
40	On/Off/Clean Switch
41	See Control Board Schematic For Detail
42	Solenoid Valve - Harvest
54	Transformer
55	Water Dump Valve
56	Water Inlet Valve
58	Water Pump

Wire Colors

BLK	Black
BLU	Blue
BRN	Brown
GRY	Grey
ORG	Orange
PRPL	Purple
RED	Red
WHT	White
YEL	Yellow

Refer to control board schematic for control board detail

Electronic Control Board

CONTROL BOARD SCHEMATIC PKM0335/PKM0425/PKM0535

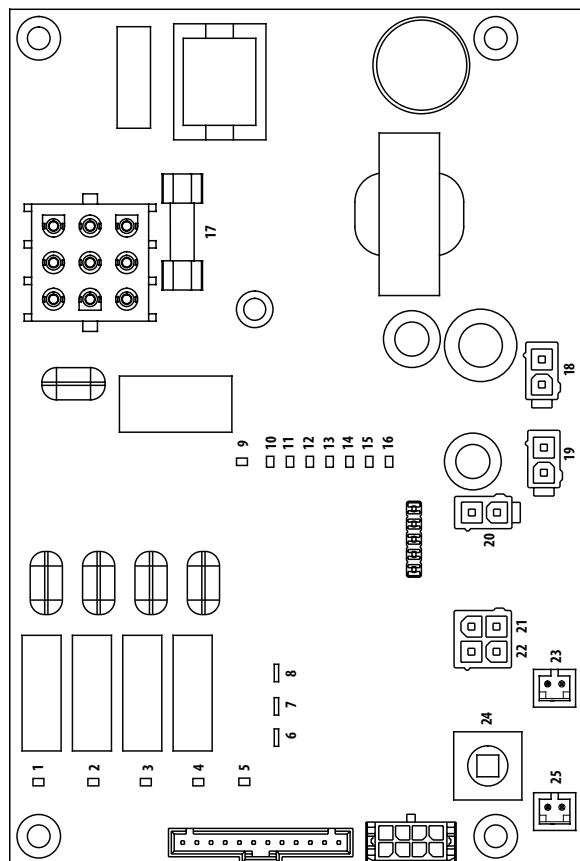

Electronic Control Board PKM0335/ PKM0425/PKM0535

Number	Component
1	LED Water Pump Relay
2	LED Compressor Relay
3	LED Water Dump Valve Relay
4	LED Harvest Solenoid Valve
5	LED Clean
6	Thermistor
7	Thermistor
8	Thermistor
9	LED Water Fill Valve
10	LED Harvest Float
11	LED Water Level Float
12	LED Bin Switch
13	LED Safety Limit 2
14	LED Safety Limit 1
15	LED Harvest
16	LED Test Mode
17	Fuse
18	Motor Connector
19	EC Fan Motor Connector
20	Bin Switch Connector
21	Float Switch Water Level
22	Float Switch Harvest
23	Thermistor 2
24	Test Switch
25	Thermistor 1

CONTROL BOARD SCHEMATIC PKU0155

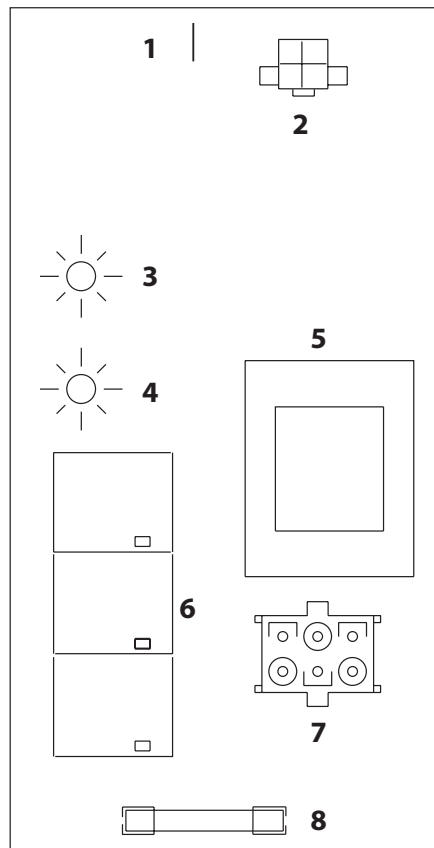

Number	Component
1	Ice Thickness Probe Connector
2	DC Low Voltage Electrical Connector
3	Bin Switch Light
4	Harvest Light
5	Transformer
6	Component Relays
7	AC Line Voltage Electrical Connector
8	10 Amp Fuse

Refrigeration Tubing Schematic

PKU0155/PKM0335/PKM0425/PKM0535

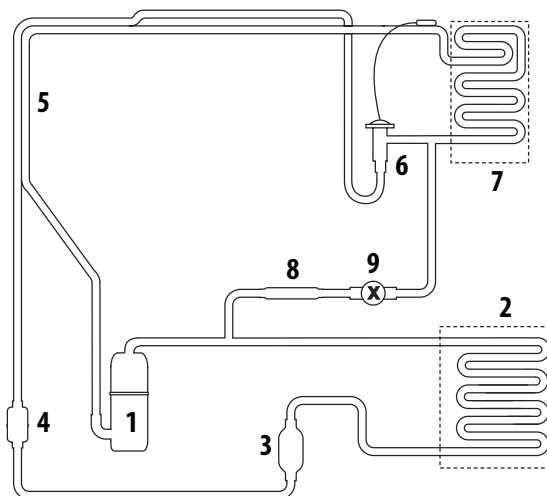

Number	Component
1	Compressor
2	Condenser-Air or Water cooled
3	Receiver - Water Cooled Only
4	Liquid Line Filter Drier
5	Heat Exchanger
6	TXV - Thermostatic Expansion Valve
7	Evaporator
8	Strainer
9	Harvest Solenoid Valve

THIS PAGE INTENTIONALLY LEFT BLANK



KaTom - 305 KaTom Drive, Kodak, Tennessee 37764

Part Number: 000016427 Rev 00 08/2020