

Project \_\_\_\_\_  
 Item \_\_\_\_\_  
 Quantity \_\_\_\_\_  
 FCSI Section 11400 \_\_\_\_\_  
 Approved \_\_\_\_\_  
 Date \_\_\_\_\_

# TRI-LEG, DIRECT STEAM TILTING, 2/3 STEAM JACKETED 25, 40 OR 60 GALLONS (100, 150 OR 225 LITERS)

## Models

- KDL-25-T
- KDL-40-T
- KDL-60-T



Shown with optional Spring-Assisted Cover, 2" Tangent Draw-Off Valve

## Options & Accessories

- Lift-off Covers (CL)
- Steam Control Kit includes: Steam Trap, Condensate Strainer, Check Valve, nipples and fittings, factory assembled and mounted on kettle (SCK2)
- Spring-assisted, hinged, rotatable, domed Stainless Steel Cover (CHS-)
- Hot and Cold Water Faucet, comes with Swing Spout (DPK)
- 2" or 3" diameter Tangent Draw-Off Valve (TD2 or TD3\*), \*TD3 for 60 gallon only and will raise height of kettle by 5-5/8" (143mm)
- 3" diameter Butterfly Valve (BV3)
- Cooking Baskets and Tri-Basket Supports (BS and TBS)
- Pan Carrier (PCK)
- Measuring Strips (MS)
- Gallon Markings (KM)
- Kettle Accessory Kit (KAK) includes:
  - Clean-up Brush (CB)
  - 36" Kettle Paddle (KP)
  - 36" Kettle Whip (KW)
  - 36" Kettle Brush (KB)
  - Draw-off Brush (DB)
  - 24 oz. Ladle (KL)
- Swing Funnels for drain (SF)
- Faucet Mounting Bracket (FBKT)
- Pressure Reducing Valve for regulating incoming steam pressure of over 45 psi (PRV-K)
- Hot and cold, or cold only, Kettle Filler with 60" Hose (DKF-K or SKF-K)
- Automatic Water Cooling\* (AWC-1)  
 \* requires Console Mounting Option
- Automatic Water Meter (GMF or LMF)
- Water Meter Stand (SWM)
- Food Strainer (FS)
- Flow Diverter (FD)
- Drain Strainers (DS-)
- Pre-Rinse Spray Head and Hose (PRSK)
- Heat Deflector Shield (HS001)
- Correctional Packages

## Short Form Specifications

Shall be CLEVELAND, Direct Steam Kettle, Tri-leg mounted, Model KDL - \_\_\_\_\_ - T, \_\_\_\_\_ gallons, Tilting (hand or power) 2/3 Steam Jacketed. 50 psi Steam Jacket Rating; Steam Control Valve; heavy re-enforced Rolled Rim. To operate, connect directly to a steam source supplying 10 to 45 psi steam. 316 Stainless Steel Interior.

## Standard Features

- Kettle legs of 15/8" OD, type 304 Stainless Steel, with 3 level adjustable feet, with three-bolt flanges for floor bolting
- Type 304 Stainless Steel construction, with #4 finish on kettle and supports
- Tilting Mechanism with permanently lubricated, self-locking, Worm Drive of space saving design
- 50 psi Steam Jacket Rating
- 50 psi chrome plated Safety Valve
- High Capacity Pouring Lip
- Condensate Drain Valve with insulated handle
- Steam Control Valve mounted on console
- Typical approvals include NSF and ASME
- 316 Stainless Steel Kettle Interior

KE004046-50

**CAPACITIES:** (in 8 oz. servings, other sizes may be calculated.)  
 25 Gallon / 100 liters . . . 400 servings  
 40 Gallon / 150 liters . . . 640 servings  
 60 Gallon / 225 liters . . . 960 servings

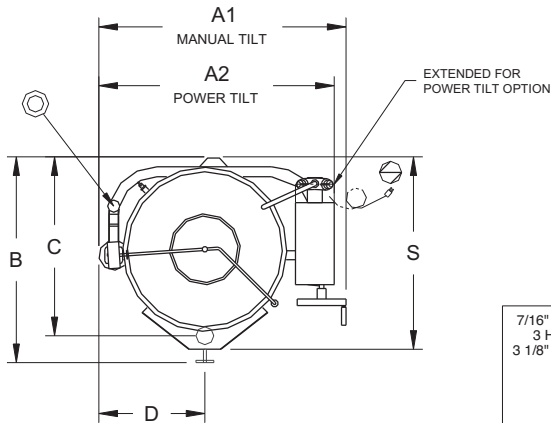

**NOTE:** TD3, 3" tangent draw off will raise height of kettle by 5-5/8" (143mm). Available on 60 gallon models only.

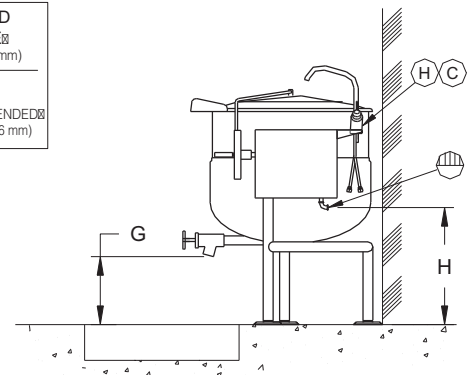
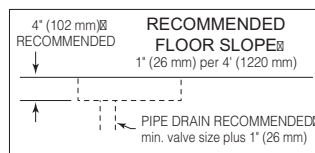
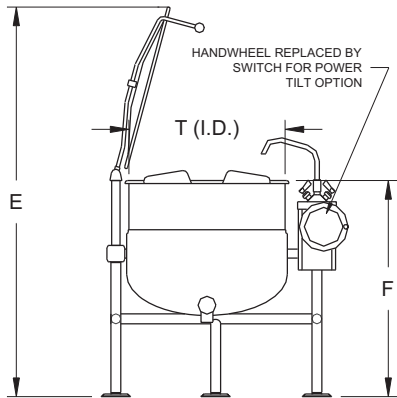
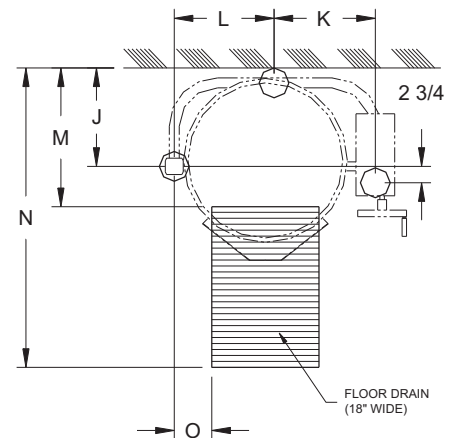
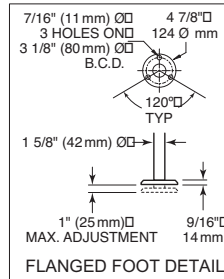

UNIT SHOWN WITH OPTIONAL 2" TANGENT DRAW-OFF VALVE, SPRING ASSIST COVER, HOT AND COLD WATER FAUCED AND STEAM CONTROL KIT.

### DIMENSIONS

GALS/ LITERS	A1	A2	B	C	D	E	F	G	H	J	K	L	M	N	O	S	T.I.D.
25	IN 37 5/8	35 1/2	33 3/8	28 5/8	15 3/8	61 7/8	36 5/8	14	18 1/2	15 1/2	14 1/2	14 1/4	21 5/8	49 1/4	3 7/8	29 5/8	21
100	mm 957	902	848	728	391	1572	931	356	470	394	369	362	550	1251	99	753	534
40	IN 41 5/8	39 1/2	34 3/4	30	17 7/8	65 7/8	36 7/8	12 1/4	19	16 1/2	17	16 3/4	23 3/8	51 1/8	6 3/8	32 3/8	26
150	mm 1058	1004	883	762	455	1674	937	312	483	420	432	426	594	1299	162	823	661
60	IN 45 1/8	43	38	33 3/8	19 5/8	74 1/8	40 7/8	12 3/4	20 1/4	18 1/2	18 3/4	18 1/2	26 5/8	56 3/8	8 1/8	36 1/4	29 1/2
225	mm 1147	1093	966	848	499	1883	1039	324	515	470	477	470	677	1432	207	921	750

Shipping Weights & Dimensions	
Model -	
KDL-25-T	Weight - 285 lbs Width - 38" Depth - 38" Height - 54"
KDL-40-T	Weight - 291 lbs Width - 44" Depth - 44" Height - 54"
KDL-60-T	Weight - 364 lbs Width - 48" Depth - 48" Height - 54"

DIRECT STEAM	ELECTRIC	WATER	CLEARANCE						
Steam Supply: • Furnish 3/4" IPS minimum line. • Operating Pressure 10 to 45 psi.	<table border="1"> <tr> <th>VOLTS 1 PH</th> <th>AMPS</th> </tr> <tr> <td>115</td> <td>5</td> </tr> <tr> <td>240</td> <td>2.5</td> </tr> </table> For Power Pour models	VOLTS 1 PH	AMPS	115	5	240	2.5	1/2" O.D. copper tube.  When ordered with optional faucet.	RIGHT = 4.00" handle clearance  LEFT = 0" REAR = 0"
VOLTS 1 PH	AMPS								
115	5								
240	2.5								

### NOTES:

Cleveland Range reserves right of design improvement or modification, as warranted.  
 Many regional, state and local codes exist and it is the responsibility of the owner and installer to comply with the codes.  
 Installation of backflow preventers, vacuum breakers and other specific code requirements is the responsibility of the owner and installer.  
 Cleveland Range equipment is built to comply with applicable standards for manufacturers. Included among those approval agencies are U.L., A.G.A., NSF, ASME/N.Bd., CSA, CGA, ETL and others.

(NOT TO SCALE)

Direct Steam Kettles