

STAND MOUNTED, DIRECT STEAM
 6, 12 OR 20 GAL. TILTING, 2/3 STEAM JACKETED (1 OR 2 EACH)
 18" HIGH STAND WITH DRAIN
 450, 650, 1050, 1200 OR 1600MM WIDTHS

Project _____
 Item _____
 Quantity _____
 FCSI Section 11400 _____
 Approved _____
 Date _____

Models

- SD-450-K6
- SD-650-K12
- SD-1050-K20
- SD-1050-K66
- SD-1200-K612
- SD-1600-K1212
- SD-1800-2020



Standard Features

- Type 304 Stainless Steel construction, with #4 finish on Kettle
- Factory Assembled Kettle/Stand combinations with available kettle capacities to suit most needs
- Steam Control Kit: includes: Needle Type Steam Control Valve, Steam Trap, Condensate Strainer, Check Valve, Nipples and Fittings, factory assembled and mounted on kettles(s)
- Kettles are Mounted on Stainless Steel Stand of Modular Cabinetized Design
- Hot and Cold Water Faucet with Swing Spout
- Table Top has Full Width Drain Trough equipped with standing 1.50" diameter male Drain Connection
- Sliding drain Catch Pan with Splash Shield, easy to position for use
- Kettles are 2/3 Steam Jacketed and include Lift-Off Covers
- 50 psi Steam Jacket Rating
- 50 psi Chrome Plated Safety Valve
- Manual Tilting, Balanced Design
- Typical approvals include NSF and ASME

Short Form Specifications

Shall be CLEVELAND, Kettle(s) with Stand, Model SD - _____ - K _____, full width Drain Trough with 1 1/2" male Drain Connection, Sliding Catch Pan and 2/3 Steam Jacketed Kettle(s) _____ ea. _____ Gallon (and _____ ea. _____ Gallon) Steam Jacket Ratings to be 50 psi; Kettle and Legs to be Type 304 Stainless Steel. To operate, connect directly to a steam source supplying from 5 to 45 psi steam. Steam Condensate Trap and Strainer, Factory Assembled and Installed; includes: Hot and Cold Water Faucet with Swing Spout and Lift-Off Kettle Covers.

Options & Accessories

- Type 316 Stainless Steel Kettle Interior for high acid food products (316)
- Cooking Basket (BS)
- Food Strainer (FS)
- Steam Pressure Reducing Valve, where supply exceeds 45 psi (PRV)
- Steam Supply Moisture Separator/Trap (MS)
- Single Pantry Faucet (SPK)
- Wall Meter, wall mount (GM For MLMF)
- Water Cooling, wall mount
- Back Wall or Back Splash (BW-32 or BS-4)
- Self Locking Hand Tilt Mechanism (HTK - 12 gallons only)

SERVICE CONNECTIONS DIAGRAM

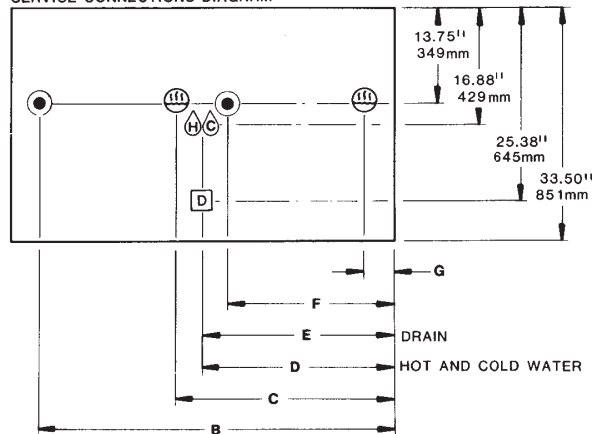

CAPACITIES: (in 4 oz. servings, other sizes may be calculated.)
 6 Gallon / 23 liters . . . 160 per kettle
 12 Gallon / 45 liters . . . 352 per kettle
 20 Gallon / 80 liters . . . 704 per kettle

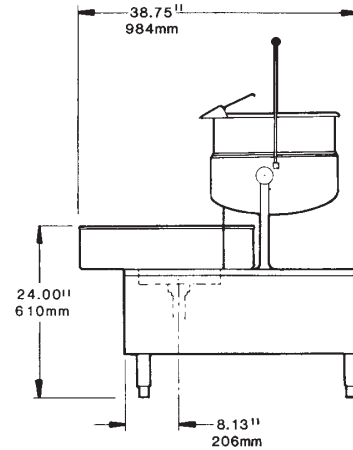
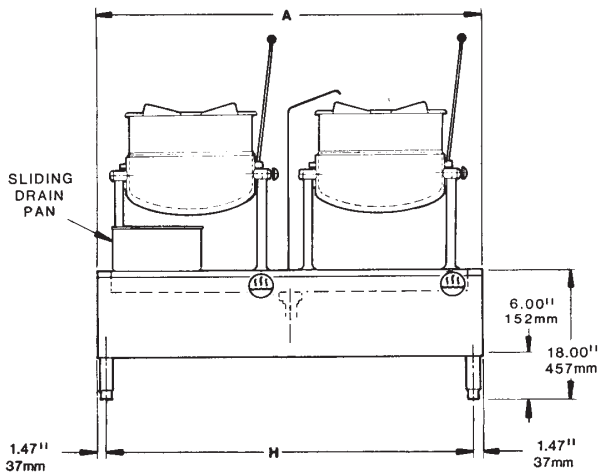

MODEL		A	B	C	D	E	F	G	H
SD- 450-K6	IN mm	17.72 450	—	—	—	8.86 225	15.97 406	3.97 101	14.78 375
SD- 650-K12	IN mm	25.59 650	—	—	—	12.80 325	23.84 606	4.34 110	22.65 575
SD-1050-K20	IN mm	41.34 1050	—	—	5.50 140	20.67 525	23.75 603	4.50 114	38.40 975
SD-1050-K66	IN mm	41.34 1050	37.09 942	25.09 637	20.67 525	20.67 525	16.25 413	4.25 108	38.40 975
SD-1200-K612	IN mm	47.24 1200	43.50 1105	31.50 800	27.75 705	23.62 600	24.00 610	4.25 108	44.30 1125
SD-1600-K1212	IN mm	62.99 1600	55.50 1410	36.00 914	31.50 800	31.50 800	27.00 686	7.50 191	60.05 1525
SD-1800-K2020	IN mm	62.99 1600	59.50 1511	35.75 908	32.00 813	31.50 800	28.25 718	4.50 114	60.05 1525

Shipping Weights & Dimensions

Model -
 SD450K6 Weight - 145 lbs
 SD650K12 Weight - 240 lbs
 SD1050K66 Weight - 302 lbs
 Width - 45"
 Depth - 44"
 Height - 55"

DIRECT STEAM	WATER	DRAIN	CLEARANCE
Steam Inlet: 1/2" IPS minimum line Total Kettle capacity: 20 gallons or less = 1/2" 25 gallons or more = 3/4" Operating Pressure: 5 to 45 psi with a 50 psi Safety Valve CONDENSATE RETURN 1/2" N.P.T.	3/8" O.D. copper tube or 1/2" NPT pipe	1 1/2" diameter American Standard straight pipe thread LF.	RIGHT = 0 LEFT = 0 REAR = 0

NOTES:

Cleveland Range reserves right of design improvement or modification, as warranted.
 Many regional, state and local codes exist and it is the responsibility of the owner and installer to comply with the codes.
 Installation of backflow preventers, vacuum breakers and other specific code requirements is the responsibility of the owner and installer.
 Cleveland Range equipment is built to comply with applicable standards for manufacturers. Included among those approval agencies are U.L., A.G.A., NSF, ASME/N.Bd., CSA, CGA, ETL and others.

(NOT TO SCALE)