



# BEVERAGE-AIR

Project: _____	AIA#
Item: _____	
Location: _____	SIS#
Approved: _____	

## SIDE MOUNT UNDERCOUNTER REFRIGERATOR

UCR46AHC Solid Door Refrigerator  
Hydrocarbon Series

MODEL:  
UCR46AHC

UCR46AHC UNDERCOUNTER REFRIGERATOR



**3 Year Parts/Labor Warranty**  
**Additional 4 Year Compressor Warranty**

### CABINET CONSTRUCTION

- Stainless steel front, sides, top, door and grille (galvanized steel back & bottom)
- Interior liner is made of corrosion resistant aluminum
- Full electronic control
- Undercounter feature a 1/2" thick sub-top
- Interior thermometer is standard
- Self-closing door with 120° stay-open feature
- Magnetic gasket attached to each door for positive seal
- 6" Casters, two (2) with brakes standard
- Two epoxy-coated steel wire shelves
- Field-reversible door

### OPTIONS & ACCESSORIES

- Stainless steel back
- Stainless steel interior
- Additional shelves
- Shelf clips
- Right or left hinged door
- Door lock
- Wire shelf divider
- 3" Casters
- 6" Legs (stainless steel, black or seismic/flange)
- Low profile casters
- Roller kit
- Remote option\* (see note on back on page)

### REFRIGERATION SYSTEM

- Uses environmentally friendly, energy efficient R290 refrigerant, and meets all regulatory requirements for CARB, SNAP, DOE & more
- Adaptive defrost
- Epoxy coated evaporator coil
- Refrigerators capable of maintaining product temperature between 36°F and 38°F



Please verify qualifying units by visiting:  
[www.energystar.gov/cfs](http://www.energystar.gov/cfs)

3779 Champion Blvd., Winston-Salem, NC 27105  
1-888-845-9800 Fax: 1-336-245-6453  
Beverage-Air.com Sales@bevair.com



# BEVERAGE-AIR

MODEL	UCR46AHC
<b>EXTERNAL DIMENSIONAL DATA</b>	
Width Overall	46"
Depth Overall with Handle & Bumper	34 3/4"
Height Overall with 6" Casters	34 1/2"
Number of Doors	1
Depth with Door Open 90°	57 1/8"
Door Opening	21 1/2" x 23 3/8"
<b>INTERNAL DIMENSIONAL DATA</b>	
NET Capacity (cubic ft.)	10.8
Internal Width Overall (in)	42"
Internal Depth Overall (in)	26"
Internal Height Overall (in)	24 3/4"
Number of Shelves	2
<b>ELECTRICAL DATA</b>	
Full Load Amperes	2.0
<b>REFRIGERATION DATA</b>	
Horsepower	1/5
Capacity (BTU/Hr)	1350
Heat Rejection (BTU/Hr)	2025
Charge (lbs/grams)	0.243/110
<b>SHIPPING DATA</b>	
Gross Weight - Crated	281 lbs
Height - Crated	40"
Width - Crated	48"
Depth - Crated	37"

\*NOTE: Remote units are field wired and come with 6" legs.  
Refrigerant must be specified at time of order.

## Undercounter Refrigerator-Side Mount Model: UCR46AHC

### Model Views

Required Clearance: 3 3/16" bottom & 2" rear

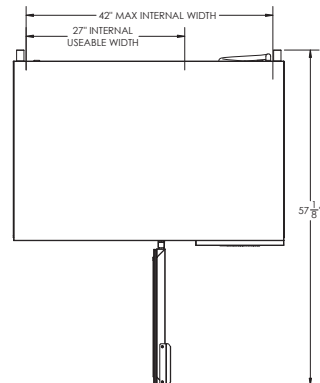

### PLAN VIEW

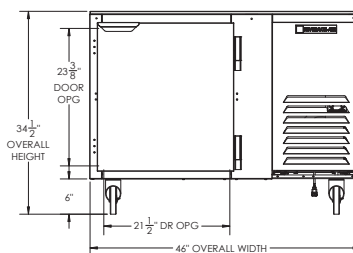

### ELEVATION VIEW

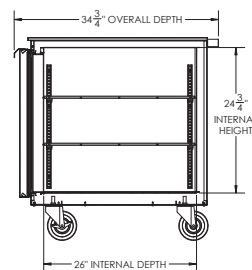

### SIDE VIEW

### ELECTRICAL CONNECTION



115/60/1  
NEMA 5-15P

Unit pre-wired at  
factory and include 8'  
long cord and plug set.



3779 Champion Blvd., Winston-Salem, NC 27105 1-888-845-9800 Fax: 1-336-245-6453 Beverage-Air.com Sales@bevoir.com

an Ali Group Company



The Spirit of Excellence