



HOSHIZAKI

Parts List

Modular Flaker

Models

F-450MAJ(-C)



hoshizakiamerica.com

Number: 71367
Issued: 5-6-2016
Revised: 3-12-2018

CONTENTS

Auxiliary Codes.....	3
Note About Ordering Parts	3
A. Main Assembly & Refrigeration Circuit	4
B. Icemaking Unit	7
C. Water Circuit.....	9
D. Control Box Assembly.....	11
E. Accessories & Labels	13

Auxiliary Codes

F-450MAJ

F-0 April 2016
F-1 November 2016
G-0 January 2017
G-1 April 2017
G-2 July 2017
H-0 January 2018

F-450MAJ-C

F-0 April 2016
F-1 November 2016
G-0 January 2017
G-1 April 2017
G-2 July 2017
H-0 January 2018

Auxiliary Code Breakdown

The auxiliary code is the first two characters in the serial number. The first character indicates the year. Years progress or regress in alphabetical order. The series runs from "A" through "V" and the letters "I" and "O" are skipped. The second character indicates significant part changes within a year. Base is "0" and this number advances for each change. In cases where there is a letter in parentheses, this designates the month. This is the last character in the serial number. The series runs from "(A)" through "(M)" and the letter "(I)" is skipped. This designation is only included when identifying a parts change within an auxiliary code.

Note About Ordering Parts

Most assemblies cannot be ordered as complete units; parts in the assemblies generally must be ordered separately.

A. Main Assembly & Refrigeration Circuit
F-450MAJ(-C)
1/2
 F-0 to H-0

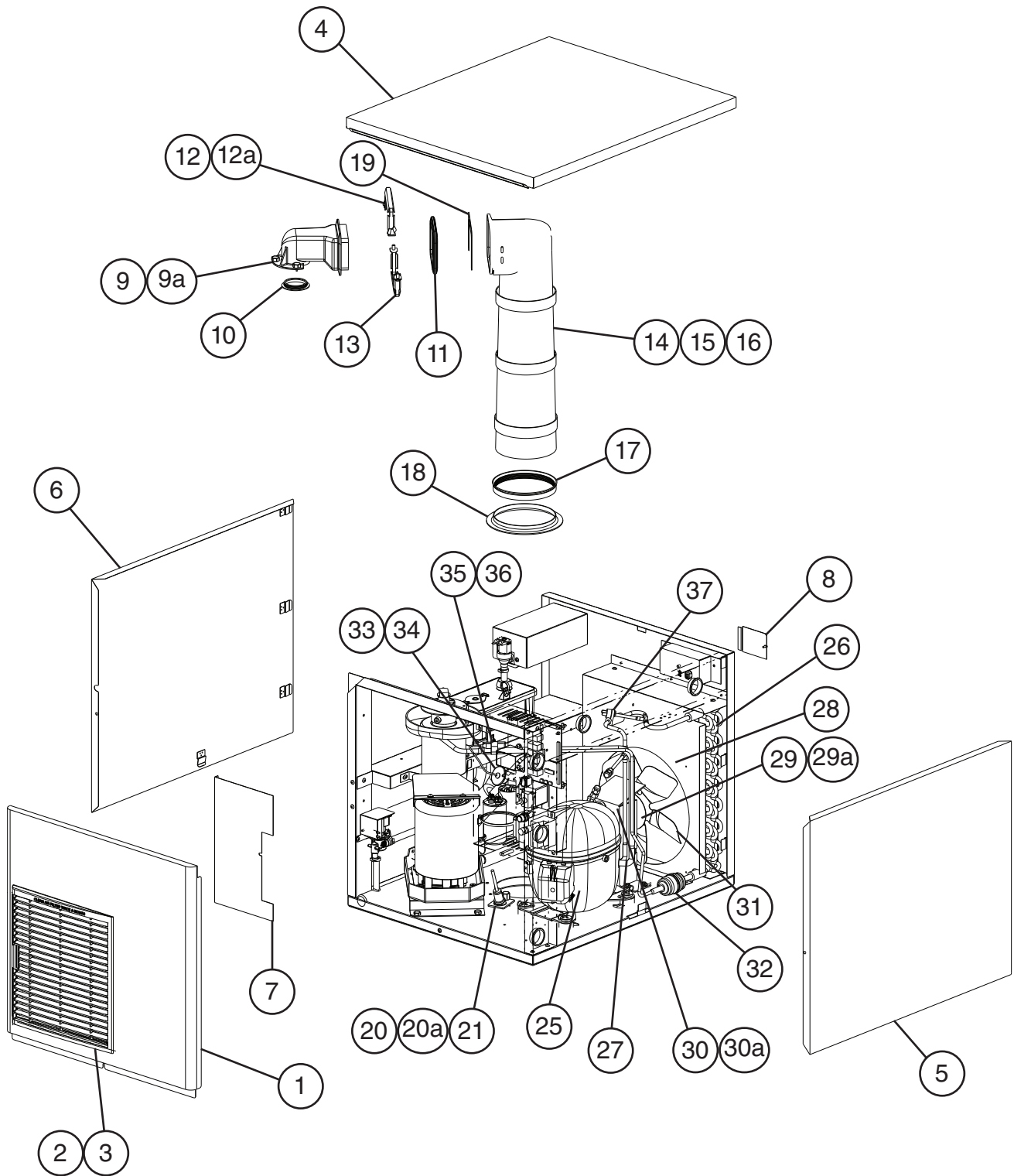

A. Main Assembly & Refrigeration Circuit
F-450MAJ(-C)
2/2
F-0 to H-0

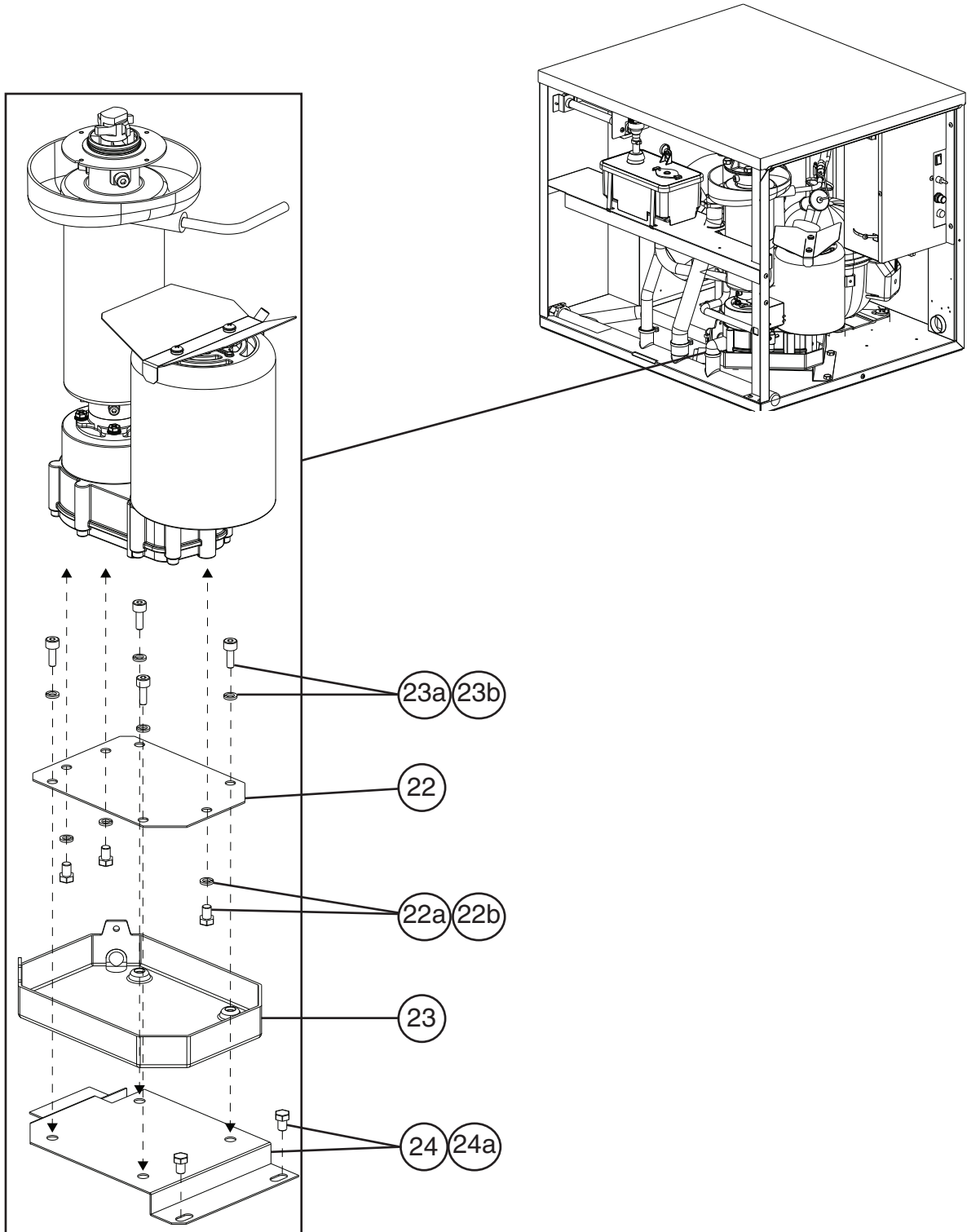

Title: A. Main Assembly & Refrigeration Circuit Model: F-450MAJ(-C)													
Index No.	Description	Material or Model Number	Part Number	Required Number									
				F-0 to H-0									
1	Front Panel		2A2065-01	1									
2	Louver		1A0547-01	1									
3	Air Filter		2A2062G01	1									
4	Top Panel		2A2064-02	1									
5	Right Side Panel		2A2067G01	1									
6	Left Side Panel		2A2066G01	1									
7	Control Box Cover		3A0411-01	1									
8	Junction Box Cover		433410-01	1									
9	Spout		2A0915-01	1									
9a	Thumbscrew		415949G08	3									
10	Evaporator Packing		427151-01	1									
11	Spout Packing		321037-01	1									
12	Upper Spout Strap		328703-02	1									
12a	Wing Nut		7E12-0600	2									
13	Lower Spout Strap		321038G02	1									
14	Chute		2A1308-02	1									
15	Chute Insulation		2A0989-01	1									
16	Tie		436531G01	3									
17	Chute Packing		432877-01	1									
18	Ring		3A1017-01	1									
19	Spout-to-Chute Bracket		4A1712-01	1									
20	Bin Control Housing		3A3478-01	1									
20a	Thumbscrew		415949G12	1									
21	Bin Control (infrared sensor)		4A4469-01	1									
22	Gear Motor Mounting Bracket		4A4308-01	1									
22a	Hex Bolt	8x12, SS	7B02-0812	3									
22b	Split Lock Washer	M8, SS	7L22-0800	3									
23	Drain Pan Assembly		4A4354G01	1									
23a	Socket Head Cap Screw	8x20, SS	7S12-0820	4									
23b	Split Lock Washer	M8, SS	7L22-0800	4									
24	Drain Pan Mounting Bracket		4A4314G01	1									
24a	Hex Bolt	8x12, SS	7B02-0812	2									
Refrigeration Circuit													
25	Compressor		4A5090-01	1									
26	Condenser		2A3476-01	1									
27	Heat Exchanger		3A8938G01	1									
28	Shroud		2A7933-01	1									
29	Fan Motor		4A3158-01	1									
29a	Self-Locking Nut		7N2110832	4									
30	Fan Motor Mounting Bracket		3A0828-01	1									
30a	Hex Head Bolt	5x12 SS	7B0230512	4									
31	Fan Blade		444898-01	1									
32	Drier		4A2666-01	1									
33	Thermostatic Expansion Valve		4A4493-01	1									
34	Thermostatic Expansion Valve Cover		4A1168-01	1									
35	Thermostatic Expansion Valve Bulb Holder		3A0112-01	1									
36	Clamp		443461-01	1									
37	High-Pressure Switch		463180-04	1									

B. Icemaking Unit
F-450MAJ(-C)
 F-0 to H-0

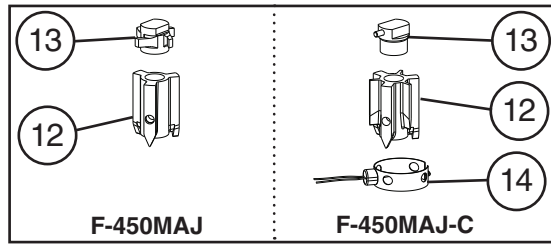

Note: When ordering auger, auxillary code G-1 and earlier must also order housing (item 4), extruding head (item 12), and seal bolts (item 12a) and replace as a set.

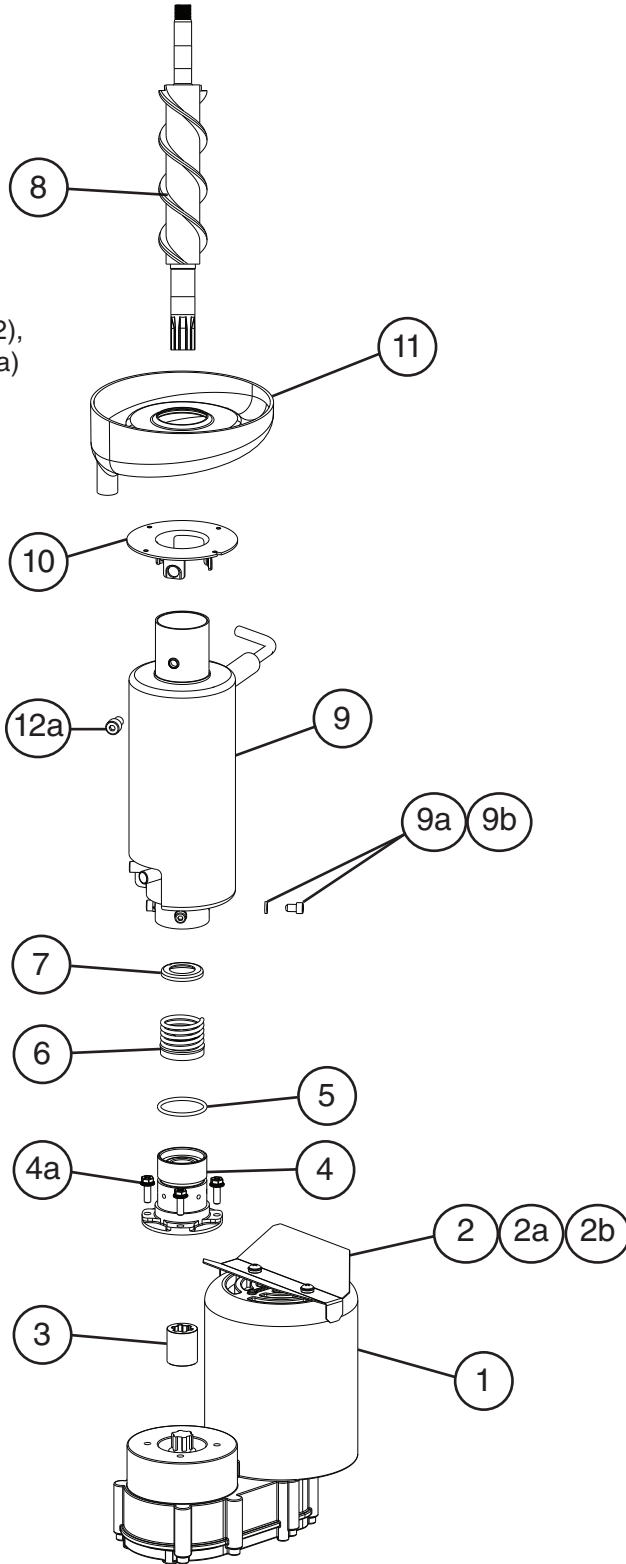

Title: B. Icemaking Unit Model: F-450MAJ(-C)												
Index No.	Description	Material or Model Number	Part Number	F-0 to H-0	Required Number							
1	Gear Motor		4A4321-01	1								
2	Shield		3A4584-01	1								
2a	Truss Head Screw	5x8	7C32-0508	2								
2b	Rubber Seal Washer		4A5268-02	2								
3	Spline Coupling		418316-01	1								
4	Housing		383613G01	1								
4a	Bolt (includes flat/lock washer)	6x20	4A1989-01	4								
5	O-Ring		4A4755-01	1								
6	Mechanical Seal		432491-01	1								
7	Ring B		432494-01	1								
8	Auger Note: When ordering auger, auxillary code G-1 and earlier must also order housing (item 4), extruding head (item 12), and seal bolts (item 12a) and replace as a set.		269912G01 See "Note" under "Description"	1								
9	Evaporator		2A7797G01	1								
9a	Socket Head Cap Screw	6x10, SS	7S12-0610	4								
9b	Split Lock Washer		7L22-0600	4								
10	Flange		464843-02	1								
11	Drip Pan		2A4118-01	1								
12	Extruding Head	F-450MAJ	340077G01	1								
		F-450MAJ-C	327141G03	1								
12a	Seal Bolt		P01768-02	3								
13	Cutter	F-450MAJ	453790-01	1								
		F-450MAJ-C	439228G01	1								
14	Evaporator Heater		4A4375-01	1								

C. Water Circuit
F-450MAJ(-C)
F-0 to H-0

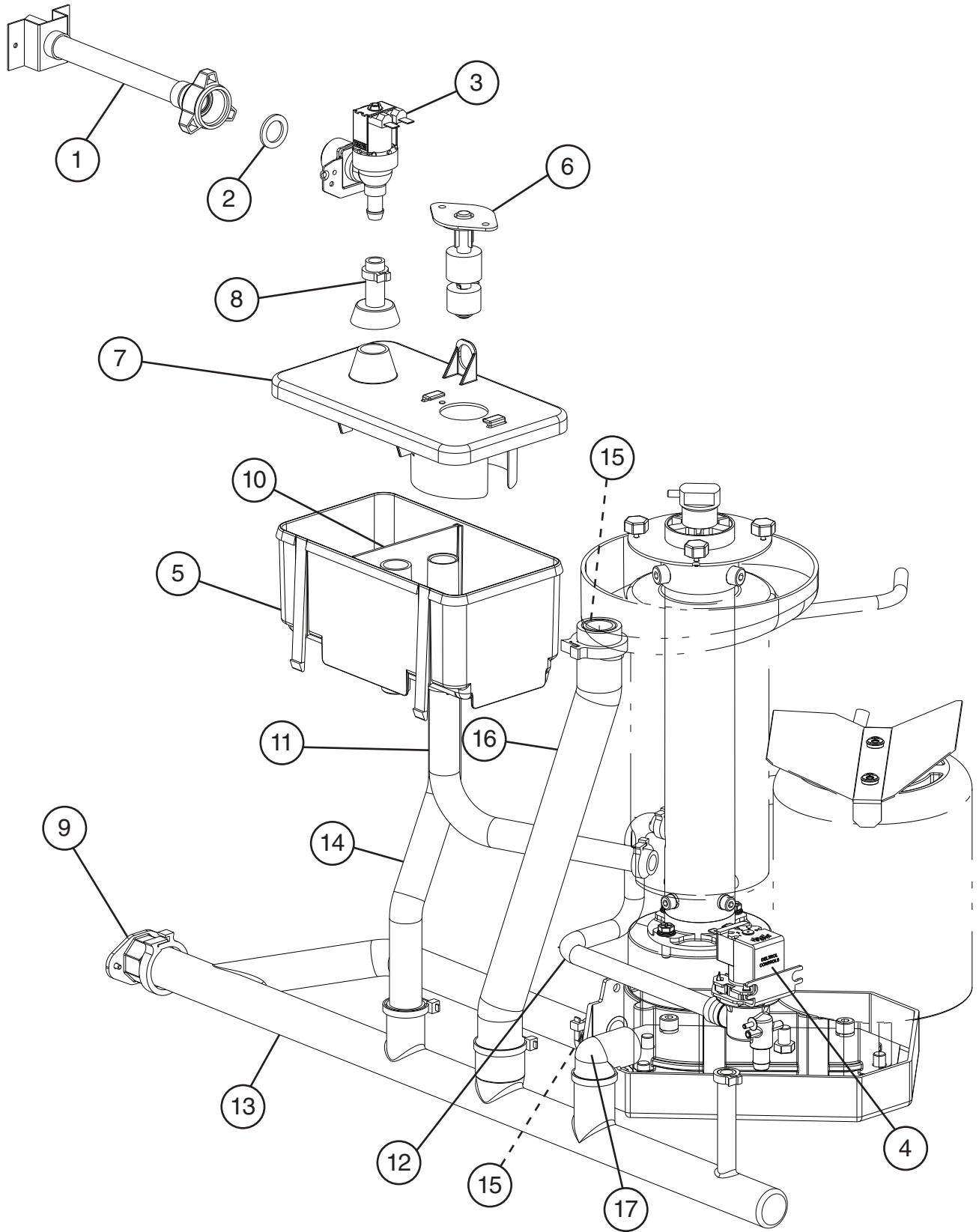

Title: C. Water Circuit Model: F-450MAJ(-C)

Index No.	Description	Material or Model Number	Part Number	F-0 to H-0	Required Number								
1	Water Supply Pipe		4A0891G04	1									
2	Rubber Gasket		413854-03	1									
3	Inlet Water Valve		4A5309-01	1									
4	Drain Valve		4A2772-02	1									
5	Reservoir		2A0753-01	1									
6	Float Switch		435490-01	1									
7	Reservoir Cover		214810-01	1									
8	Reservoir Inlet		4A0869-01	1									
9	Drain Fitting		4A5528-01	1									
10	Reservoir Separator		4A1255-01	1									
11	Reservoir Hose		4A1165-05	1									
12	Silicone Hose	L=332 mm	773013896	1									
13	Drain Hose		3A8170-01	1									
14	Vinyl Hose	L=289 mm	7725-1923	1									
15	Vinyl Hose	L=30 mm	7725-1923	2									
16	Vinyl Hose	L=345 mm	4A0658L01	1									
17	Elbow		4A5624-01	1									
Clamps													
	Hose Clamp	32-37 mm	4A2017-03	2									
	Hose Clamp	17-21 mm	4A2017-05	1									
	Hose Clamp	19-22 mm	4A2017-06	1									
	Hose Clamp	13.5-15 mm	4A2017-08	4									

D. Control Box Assembly
F-450MAJ(-C)
F-0 to H-0

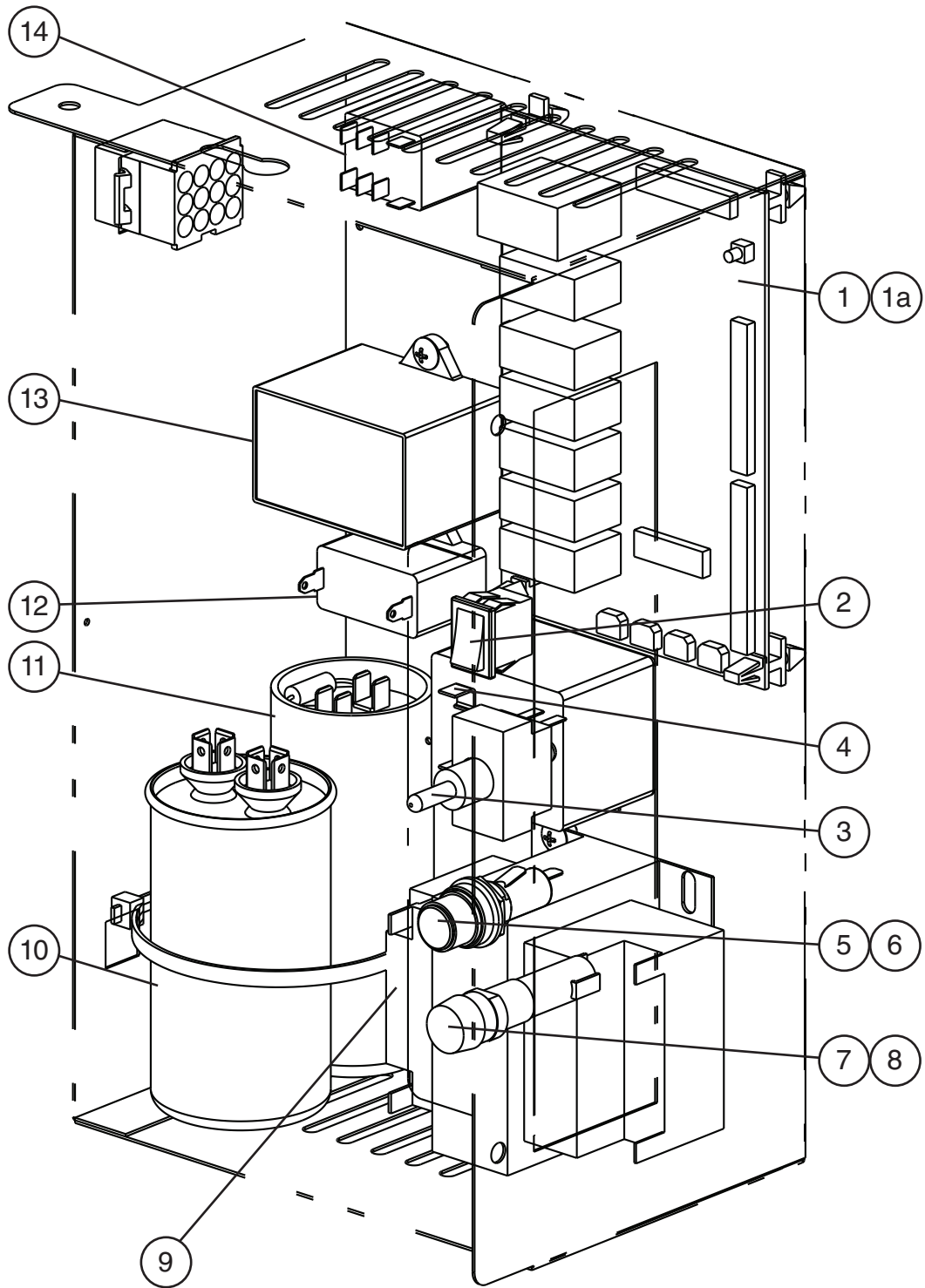

Title: D. Control Box Assembly Model: F-450MAJ(-C)												
Index No.	Description	Material or Model Number	Part Number	F-0 to H-0	Required Number							
1	Control Board		2A8054-01	1								
1a	Control Board Support		4A0336-03	4								
2	Control Switch (rocker)		4A0558-01	1								
3	Power Switch (toggle)		4A2332-01	1								
4	Start Relay		4A1107-18	1								
5	Fuse Holder		4A5443-01	1								
6	Fuse	AGC-3A, 250VAC	4A0893-03	1								
7	Fuse Holder		4A6101-01	1								
8	Fuse	GMD-2.0A, 250VAC	4A0893-05	1								
9	Control Transformer		4A0507-01	1								
10	Run Capacitor	35MFD, 440VAC	3A2005-12	1								
11	Start Capacitor	243-292MFD, 165VAC	3A0076-20	1								
12	Fan Motor Capacitor	5MFD, 250VAC	443192-02	1								
13	Gear Motor Capacitor	20MFD, 350VAC	4A4319-01	1								
14	Compressor Control Relay	120VAC	406132-07	1								

E. Accessories & Labels

F-450MAJ(-C)

F-0 to H-0

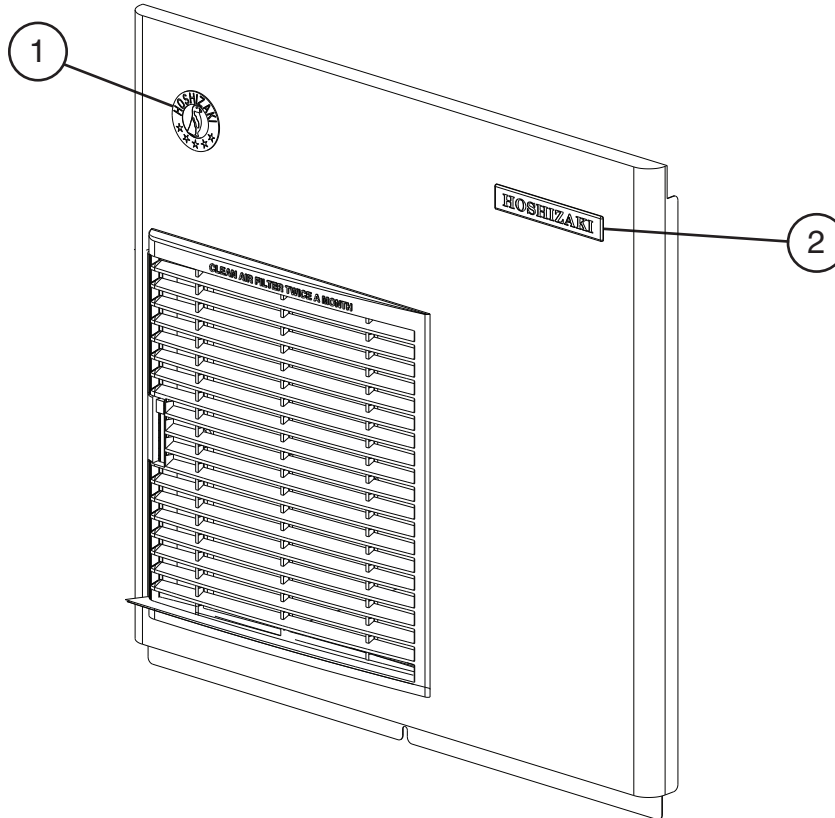

Title: E. Accessories & Labels Model: F-450MAJ(-C)					Required Number							
Index No.	Description	Material or Model Number	Part Number	F-0 to H-0								
1	Penguin-Ha Label		475552L02	1								
2	Hoshizaki Emblem		4A0560-01	1								
3	Universal Brace		4A0363-01	2								
3a	Hex Head Bolt	5x12, SS	7B02-0512	2								



HOSHIZAKI

Parts List

Storage Bin

Models

B-250PF	B-300SF
B-300PF	B-500SF
B-500PF	B-700SF
B-700PF	B-800SF
B-800PF	B-900SF
B-900PF	BD-300SF
BD-300PF	BD-500SF
BD-500PF	



CONTENTS

Auxiliary Codes.....	3
Note About Ordering Parts	6
A. Storage Bin.....	7
B. Accessories & Labels	10

Auxiliary Codes

B-250PF

L-5 August 2001
M-5 February 2002
N-5 December 2002
P-5 December 2003
Q-5 December 2004
R-5 December 2005
S-5 January 2007
T-5 January 2008
U-5 January 2009
V-5 January 2010
A-5 January 2011
B-5 January 2012
C-5 January 2013
D-5 January 2014
E-5 January 2015
E-6 August 2015
F-5 January 2016
G-5 January 2014

B-300PF

L-5 July 2001
M-5 December 2001
N-5 December 2002
P-5 December 2003
Q-5 December 2004
R-5 December 2005
S-5 January 2007
T-5 January 2008
U-5 January 2009
V-5 January 2010
A-5 January 2011
B-5 January 2012
C-5 January 2013
D-5 January 2014
D-6 March 2014
E-5 January 2015
E-6 August 2015
F-5 January 2016
G-5 January 2017

BD-300PF

A-5 April 2011
D-5 April 2014
E-5 February 2015
E-6 October 2015
F-5 May 2016
G-5 January 2017

B-500PF

L-5 June 2001
M-5 December 2001
N-5 December 2002
P-5 December 2003
Q-5 December 2004
R-5 December 2005
S-5 January 2007
T-5 January 2008
U-5 January 2009
V-5 January 2010
A-5 January 2011
B-5 January 2012
C-5 January 2013
D-5 January 2014
E-5 January 2015
E-6 August 2015
F-5 January 2016
G-5 January 2017

BD-500PF

A-5 July 2011
B-5 April 2015
C-5 April 2013
D-5 January 2014
E-5 January 2015
E-6 September 2015
F-5 February 2016
G-5 January 2017

B-700PF

L-5 June 2001
M-5 December 2001
N-5 December 2002
P-5 December 2003
Q-5 December 2004
R-5 December 2005
S-5 January 2007
T-5 January 2008
U-5 January 2009
V-5 January 2010
A-5 January 2011
B-5 January 2012
C-5 January 2013
D-5 January 2014
E-5 January 2015
E-6 August 2015
F-5 January 2016
G-5 January 2017

B-800PF

L-5 June 2001
M-5 December 2001
N-5 December 2002
P-5 December 2003
Q-5 December 2004
R-5 December 2005
S-5 January 2007
T-5 January 2008
U-5 January 2009
V-5 January 2010
A-5 January 2011
B-5 January 2012
C-5 January 2013
D-5 January 2014
E-5 January 2015
E-6 August 2015
F-5 January 2016
G-5 January 2017

B-900PF

L-5 June 2001
M-5 December 2001
N-5 December 2002
P-5 January 2004
Q-5 December 2004
R-5 December 2005
S-5 January 2007
T-5 January 2008
U-5 January 2009
V-5 January 2010
A-5 January 2011
B-5 January 2012
C-5 January 2013
D-5 January 2014
E-5 January 2015
E-6 August 2015
F-5 January 2016
G-5 January 2017

Auxiliary Codes Continued

B-300SF

L-5 June 2001
M-5 December 2001
N-5 December 2002
P-5 December 2003
Q-5 December 2004
R-5 December 2005
S-5 January 2007
T-5 January 2008
U-5 January 2009
V-5 February 2010
A-5 January 2011
B-5 January 2012
C-5 January 2013
D-5 January 2014
D-6 February 2014
E-5 January 2015
E-6 August 2015
F-5 January 2016
G-5 January 2017

BD-300SF

A-5 April 2011
D-5 April 2014
E-5 February 2015
E-6 October 2015
F-5 October 2016
G-5 February 2017

B-500SF

L-5 June 2001
M-5 December 2001
N-5 December 2002
P-5 December 2003
Q-5 December 2004
R-5 December 2005
S-5 January 2007
T-5 January 2008
U-5 January 2009
V-5 January 2010
A-5 January 2011
B-5 January 2012
C-5 January 2013
D-5 January 2014
E-5 January 2015
E-6 August 2015
F-5 January 2016
G-5 January 2017

BD-500SF

A-5 April 2011
B-5 March 2012
C-5 May 2013
D-5 February 2014
E-5 May 2015
E-6 August 2015
F-5 June 2016
G-5 March 2017

B-700SF

L-5 September 2001
M-5 December 2001
N-5 December 2002
P-5 December 2003
Q-5 December 2004
R-5 December 2005
S-5 January 2007
T-5 January 2008
U-5 January 2009
V-5 January 2010
A-5 January 2011
B-5 January 2012
C-5 January 2013
D-5 January 2014
E-5 January 2015
E-6 August 2015
F-5 January 2016
G-5 January 2017

B-800SF

L-5 September 2001
M-5 December 2001
N-5 December 2002
P-5 December 2003
Q-5 December 2004
R-5 December 2005
S-5 January 2007
T-5 January 2008
U-5 January 2009
V-5 January 2010
A-5 January 2011
B-5 January 2012
C-5 January 2013
D-5 January 2014
E-5 January 2015
E-6 August 2015
F-5 January 2016
G-5 January 2017

Auxiliary Codes Continued

B-900SF

L-5	June 2001
M-5	December 2001
N-5	January 2003
P-5	December 2003
Q-5	December 2004
R-5	December 2005
S-5	January 2007
T-5	January 2008
U-5	January 2009
V-5	January 2010
A-5	January 2011
B-5	January 2012
C-5	January 2013
D-5	January 2014
E-5	January 2015
E-6	August 2015
F-5	January 2016
G-5	January 2017

Auxiliary Code Breakdown

The auxiliary code is the first two characters in the serial number. The first character indicates the year. Years progress or regress in alphabetical order. The series runs from "A" through "V" and the letters "I" and "O" are skipped. The second character indicates significant part changes within a year. Base is "5" and this number advances for each change. In cases where there is a letter in parentheses, this designates the month. This is the last character in the serial number. The series runs from "(A)" through "(M)" and the letter "(I)" is skipped. This designation is only included when identifying a parts change within an auxiliary code.

Note About Ordering Parts

Most assemblies cannot be ordered as complete units; parts in the assemblies generally must be ordered separately.

A. Storage Bin

B-___PF, BD-___PF, B-___SF, BD-___SF

L-5 to G-5

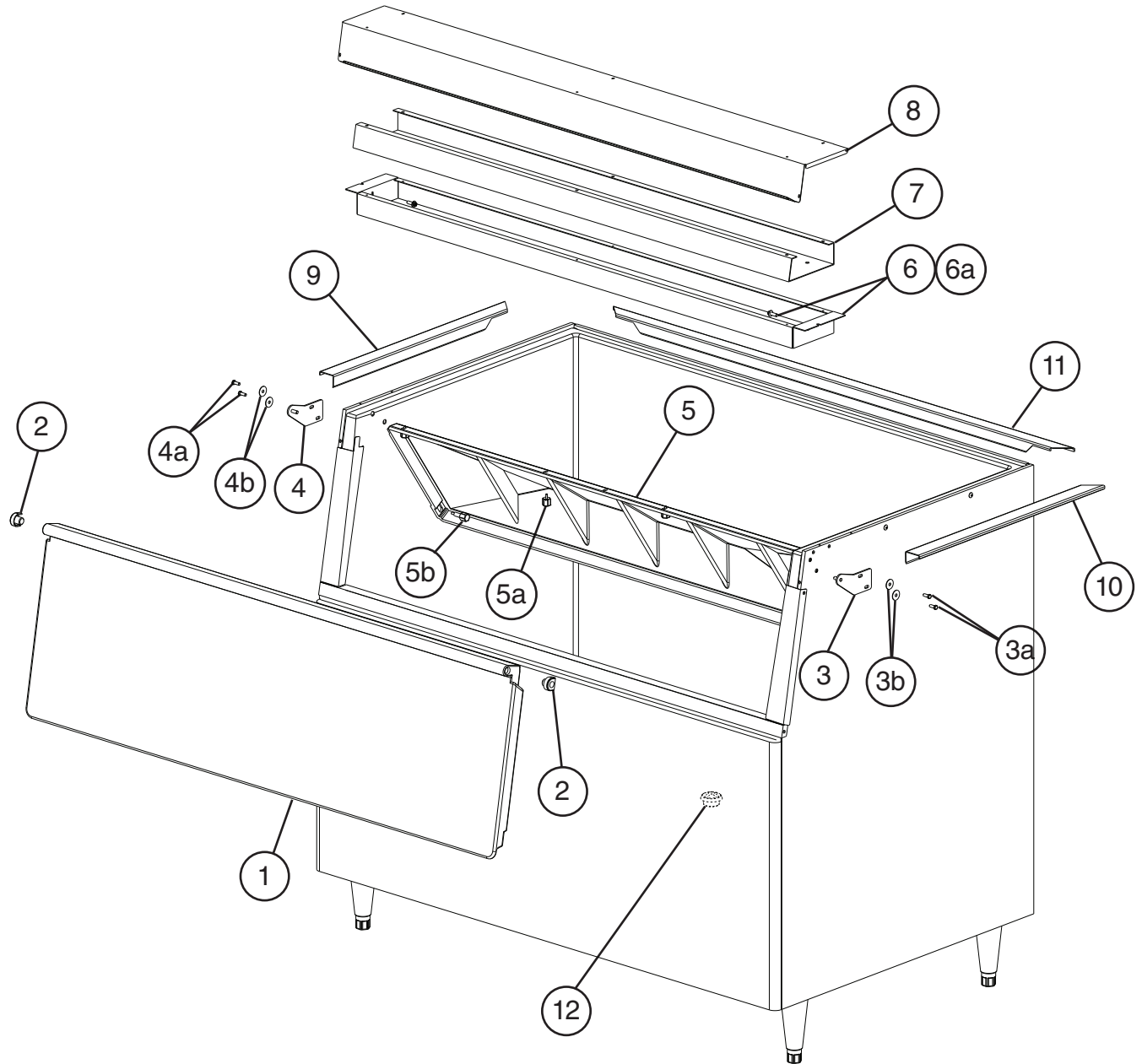

Model Shown: B-900PF

Title: A.Storage Bin Model: B-___PF, BD-___PF, B-___SF, BD-___SF												
Index No.	Description	Material or Model Number	Part Number	Required Number								
				L-5 to U-5 (C)	U-5 (D) to V-5	A-5 to D-5	D-6 to G-5					
1	Bin Door (includes item 2)	B-250PF	HS-2144	1	1	1	1					
		B-500PF/SF										
		BD-500PF/SF				1	1					
		B-300PF/SF	HS-2143	1	1	1	1					
		BD-300PF/SF				1	1					
		B-700PF/SF	HS-2140	1	1	1	1					
B-800PF/SF	HS-2141	1	1	1	1							
B-900PF/SF	HS-2142	1	1	1	1							
2	Bushing		4A2582-01	2	-							
			4A3914-01		2	2	2					
3	Right Hinge		3A0105G01	1	-							
			3A3725G01		1	1	1					
3a	Hex Head Bolt	5x14, SS	7B02-0514	2	2	2	2					
3b	Washer		4A0198-01	2	2	2	2					
4	Left Hinge		3A0106G01	1	-							
			3A3726G01		1	1	1					
4a	Hex Head Bolt	5x14, SS	7B02-0514	2	2	2	2					
4b	Washer		4A0198-01	2	2	2	2					
5	Baffle	B-250PF	104322-01	1	1	1	1					
		B-500PF/SF										
		BD-500PF/SF				1	1					
		B-300PF/SF	104391-01	1	1	1	1					
		BD-300PF/SF				1	1					
		B-700PF/SF	104323-01	1	1	1	1					
B-800PF/SF	105012-01	1	1	1	1							
B-900PF/SF	104324-02	1	1	1	1							
5a	Thumbscrew	B-250PF	415949G12	2	2	2	2					
		B-300PF/SF										
		BD-300PF/SF										
		B-500PF/SF										
BD-500PF/SF												
B-700PF/SF			3	3	3	3						
B-800PF/SF			4	4	4	4						
B-900PF/SF												
5b	Thumbscrew		434168G01	2	2	2	2					
6	Front Frame	B-250PF	3A0420-01	1	1	1	1					
		B-500PF/SF										
		B-300PF/SF	3A8180-01				1					
		BD-300PF/SF	3A6594-01			1	1					
		BD-500PF/SF	3A6594-02			1	1					
		B-700PF/SF	3A0446-01	1	1	1	1					
B-800PF/SF	3A0447-01	1	1	1	1							
B-900PF/SF	3A0447-02	1	1	1	1							
6a	Hex Head Tapping Screw		7B03I0834	2	2	2	2					

Title: A.Storage Bin Model: B-___PF, BD-___PF, B-___SF, BD-___SF											
Index No.	Description	Material or Model Number	Part Number	Required Number							
				L-5 to U-5 (C)	U-5 (D) to V-5	A-5 to D-5	D-6 to G-5				
7	Front Frame Cover	B-250PF B-500PF/SF	324625-01	1	1	1	1				
		B-300PF/SF	324617-01	1	1	1	1				
		B-700PF/SF	3A0155-01	1	1	1	1				
		B-800PF/SF	325510-01	1	1	1	1				
		B-900PF/SF	324619-01	1	1	1	1				
8	Top Cover	B-250PF B-500PF/SF	3A0157-01	1	1	1	1				
		B-300PF/SF	3A0156-01	1	1	1	-				
			3A8189-01				1				
		BD-300PF/SF	3A6538-01			1	1				
		BD-500PF/SF	3A6537-01			1	1				
		B-700PF/SF	3A0158-01	1	1	1	1				
		B-800PF/SF	2A0106-01	1	1	1	1				
B-900PF/SF	2A0107-01	1	1	1	1						
9	Right Bin Cap	B-250PF B-300PF/SF B-500PF/SF B-700PF/SF B-800PF/SF B-900PF/SF	3A7473-01				1				
10	Left Bin Cap	B-250PF B-300PF/SF B-500PF/SF B-700PF/SF B-800PF/SF B-900PF/SF	3A7474-01				1				
11	Back Bin Cap	B-250PF B-500PF/SF	3A7475-02				1				
		B-300PF/SF	3A7475-01				1				
		B-700PF/SF	3A7475-03				1				
		B-800PF/SF	3A7475-05				1				
		B-900PF/SF	3A7475-04				1				
12	Drain Cap		322015-01	1	1	1	1				

B. Accessories & Labels

B-___PF, BD-___PF, B-___SF, BD-___SF

L-5 to G-5

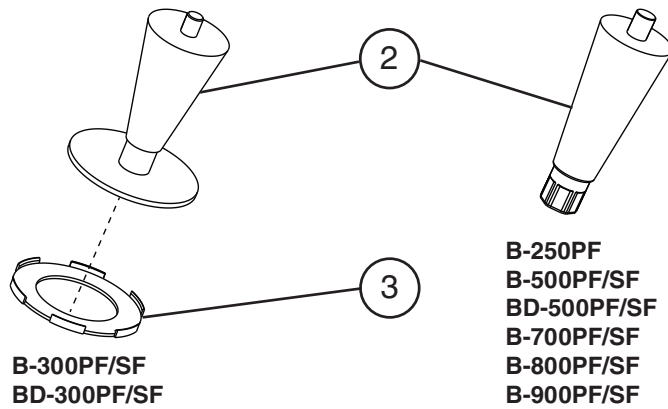
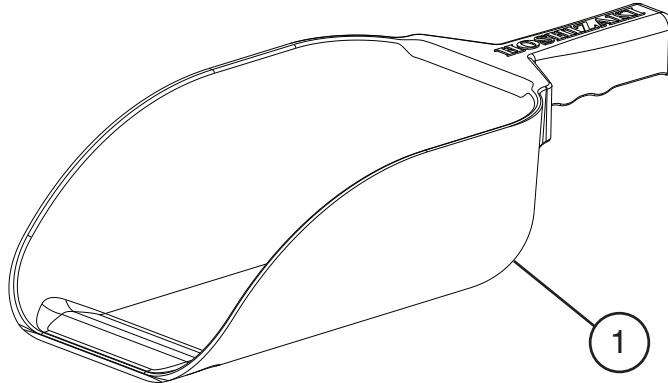

Title: B. Accessories & Labels Model: B-___PF, BD-___PF, B-___SF, BD-___SF					Required Number								
Index No.	Description	Material or Model Number	Part Number	L-5 to G-5									
1	Scoop		4A2246-01	1									
2	Leg	B-300PF/SF BD-300PF/SF	4A2526-01	4									
		B-250PF B-500PF/SF BD-500PF/SF B-700PF/SF B-800PF/SF B-900PF/SF	4A2525-01	4									
3	Leg Protector	B-300PF/SF BD-300PF/SF	3A0134-01	4									