



HOSHIZAKI

Parts List

Modular Crescent Cuber

Models

KM-350MAJ, MWJ

KM-520MAJ, MWJ, MRJ, MRZ

KM-660MAJ, MWJ, MRJ, MRJZ



hoshizakiamerica.com

Number: 71416
Issued: 8-29-2018
Revised: 1-14-2022

CONTENTS

Auxiliary Codes.....	3
Note About Ordering Parts	4
A. Main Assembly and Refrigeration Circuit.....	5
KM-350MAJ, KM-520MAJ, KM-660MAJ	5
KM-350MWJ, KM-520MWJ, KM-660MWJ	8
KM-520MRJ, KM-520MRJZ, KM-660MRJ, KM-660MRJZ	10
B. Water Circuit	12
C. Control Box Assembly	14
D. Accessories & Labels	17

Auxiliary Codes

KM-350MAJ

H-0 May 2018
J-0 January 2019
J-1 November 2019
K-0 January 2020
K-1 June 2020
K-2 October 2020
L-0 January 2021
L-1 September 2021

KM-350MWJ

H-0 May 2018
J-0 January 2019
J-1 November 2019
K-0 January 2020
K-1 October 2020
L-0 January 2021
L-1 September 2021
L-2 November 2021

KM-520MAJ

H-0 May 2018
J-0 January 2019
J-1 November 2019
K-0 January 2020
K-1 July 2020
K-2 October 2020
L-0 January 2021

KM-520MWJ

H-0 May 2018
J-0 February 2019
J-1 November 2019
K-0 January 2020
K-1 October 2020
L-0 January 2021
L-1 September 2021

KM-520MRJ

H-0 May 2018
J-0 January 2019
J-1 November 2019
K-0 February 2020
K-1 October 2020
L-0 January 2021

KM-520MRJZ

L-0 October 2021
L-1 November 2021

KM-660MAJ

H-0 May 2018
J-0 February 2019
J-1 November 2019
K-0 January 2020
K-1 July 2020
K-2 October 2020
L-0 January 2021

KM-660MWJ

H-0 May 2018
J-0 February 2019
J-1 November 2019
K-0 January 2020
K-1 October 2020
L-0 January 2021

KM-660MRJ

H-0 May 2018
J-0 January 2019
J-1 November 2019
K-0 February 2020
K-1 November 2020
L-0 January 2021

KM-660MRJZ

L-0 October 2021
L-1 November 2021

***K Control Board (2A8242-02) to K+ Control Board (2A9678-01) and UltraSonic Bin Control(4A6148G01)to Mechanical Bin Control(2A8598G01) Auxiliary Code Break**

K+ Control Board (2A9678-01)

KM-350MAJ L19077K to L19236K and Later

KM-520MAJ L02153K to L02411K and Later

KM-660MAJ L05262K to L05441K and Later

KM-660MWJ L00674K to L00693K and Later

Mechanical Bin Control 2A8598G01

KM-350MAJ L19077K to L19236K and Later

KM-520MAJ L02153K to L02411K and Later

KM-660MAJ L05262K to L05441K and Later

KM-660MWJ L00674K to L00693K and Later

Auxiliary Code Breakdown

The auxiliary code is the first two characters in the serial number. The first character indicates the year. Years progress or regress in alphabetical order. The series runs from "A" through "V" and the letters "I" and "O" are skipped. The second character indicates significant part changes within a year. Base is "0" and this number advances for each change. In cases where there is a letter in parentheses, this designates the month. This is the last character in the serial number. The series runs from "(A)" through "(M)" and the letter "(I)" is skipped. This designation is only included when identifying a parts change within an auxiliary code.

Note About Ordering Parts

Most assemblies cannot be ordered as complete units; parts in the assemblies generally must be ordered separately.

A. Main Assembly and Refrigeration Circuit
KM-350MAJ, KM-520MAJ, KM-660MAJ
 H-0 to L-1

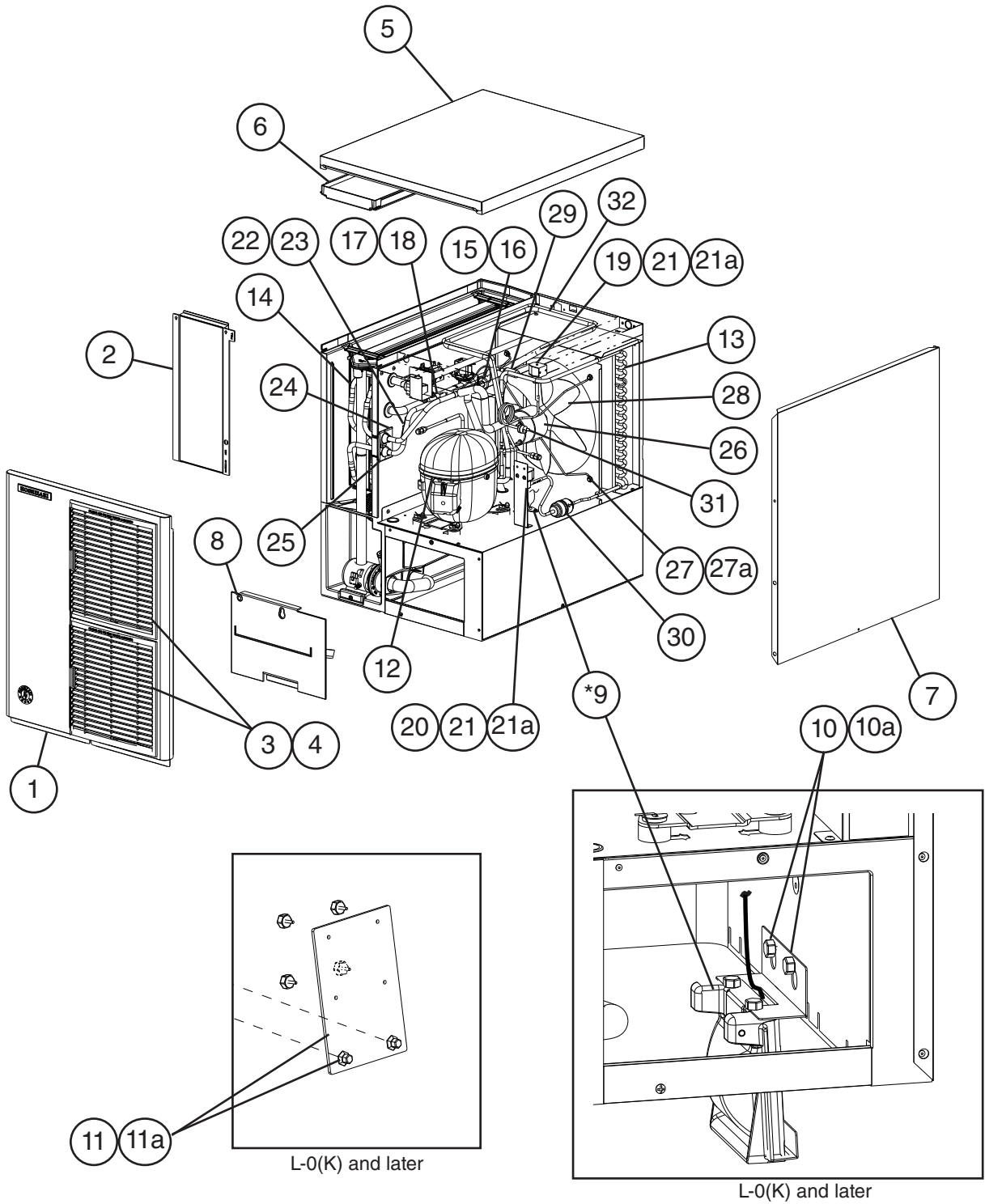

Title: A. Main Assembly and Refrigeration Circuit Model: KM-350MAJ, KM-520MAJ, KM-660MAJ												
Index No.	Description	Material or Model Number	Part Number	Required Number								
				H-0 to L-0(J)	L-0(K)	L-0(L) to L-1(J)	L-1(K)	L-1(L) to L-1(M)				
Main Assembly												
1	Front Panel		1A6158G01	1	1	1	1	1				
2	Front Insulation		3A9354G01	1	1	1	1	1				
3	Louver (includes item 4)		2A6649A01	2	2	2	2	2				
4	Air Filter		2A2062G01	2	2	2	2	2				
5	Top Panel		1A4554-01	1	1	1	1	1				
6	Top Insulation		3A9353G01	1	1	1	1	1				
7	Right Side Panel		1A5480-01	1	1	1	1	1				
8	Base Cover		3A9771-01	1	1	1	1	1				
*9	Ultra Sonic Bin Control *See page 4 "Aux Code Break."	KM-350MAJ	4A6148G01	1	1	1	*1	1				
		KM-520MAJ		1	*1	1	1	1				
		KM-660MAJ		1	-	1	1	1				
	Mechanical Bin Control *See page 4 "Aux Code Break."	KM-350MAJ	2A8598G01				*1	-				
		KM-520MAJ			*1	-						
		KM-660MAJ			1	-						
10	Mechanical Bin Control Bracket	KM-350MAJ	3A8283-02				*1	-				
		KM-520MAJ			*1	-						
		KM-660MAJ			1	-						
10a	Thumbscrews	KM-350MAJ	415949G08				*2	-				
		KM-520MAJ			*2	-						
		KM-660MAJ			*2	-						
11	Mechanical Bin Control Extention Bracket	KM-350MAJ	4A5046G01				*1	-				
		KM-520MAJ			*1	-						
		KM-660MAJ			*1	-						
11a	Thumbscrews	KM-350MAJ	415949G08				*6	-				
		KM-520MAJ			*6	-						
		KM-660MAJ			*6	-						
Refrigeration Circuit												
12	Compressor	KM-350MAJ	4A5090-01	1	1	1	1	1				
		KM-520MAJ	4A4479-01	1	1	1	1	1				
		KM-660MAJ	4A5158-01	1	1	1	1	1				
13	Condenser	KM-350MAJ	1A4582-01	1	1	1	1	1				
		KM-520MAJ	1A4584-01	1	1	1	1	1				
		KM-660MAJ										
14	Evaporator		1A4119G01	1	1	1	1	1				
15	Thermostatic Expansion Valve		4A4008-02	1	1	1	1	1				
16	Thermostatic Expansion Valve Cover		3A0944-01	1	1	1	1	1				
17	Thermostatic Expansion Valve Bulb Holder		3A0107-01	1	1	1	1	1				
18	Hose Clamp		443461-02	1	1	1	1	1				
19	Hot Gas Valve Body		4A3978-01	1	1	1	1	1				
20	Liquid Line Valve Body		4A3276-01	1	1	1	1	1				
21	Valve Coil		4A3277-01	2	2	2	2	2				
21a	Bolt		4A3277F01	2	2	2	2	2				
22	Thermistor		429006-03	1	1	1	1	1				
23	Thermistor Holder		427430-01	1	1	1	1	1				

Title: A. Main Assembly and Refrigeration Circuit Model: KM-350MAJ, KM-520MAJ, KM-660MAJ												
Index No.	Description	Material or Model Number	Part Number	Required Number								
				H-0 to L-0(J)	L-0(K)	L-0(L) to L-1(J)	L-1(K)	L-1(L) to L-1(M)				
24	Rubber Insulation A		3A9637-01	1	1	1	1	1				
25	Rubber Insulation B		3A9638-01	1	1	1	1	1				
26	Fan Motor		4A3158-01	1	1	1	1	1				
27	Fan Motor Bracket		2A9618-02	1	1	1	1	1				
27a	Hex Bolt	5x12, SS	7B0230512	4	4	4	4	4				
28	Fan Blade		4A0197-01	1	1	1	1	1				
29	Strainer		441569-02	1	1	1	1	1				
30	Drier		4A1113-01	1	1	1	1	1				
31	High-Pressure Switch		463180-01	1	1	1	1	1				
32	Heat Exchanger		2A9117G01	1	1	1	1	1				

A. Main Assembly and Refrigeration Circuit
KM-350MWJ, KM-520MWJ, KM-660MWJ
 H-0 to L-2

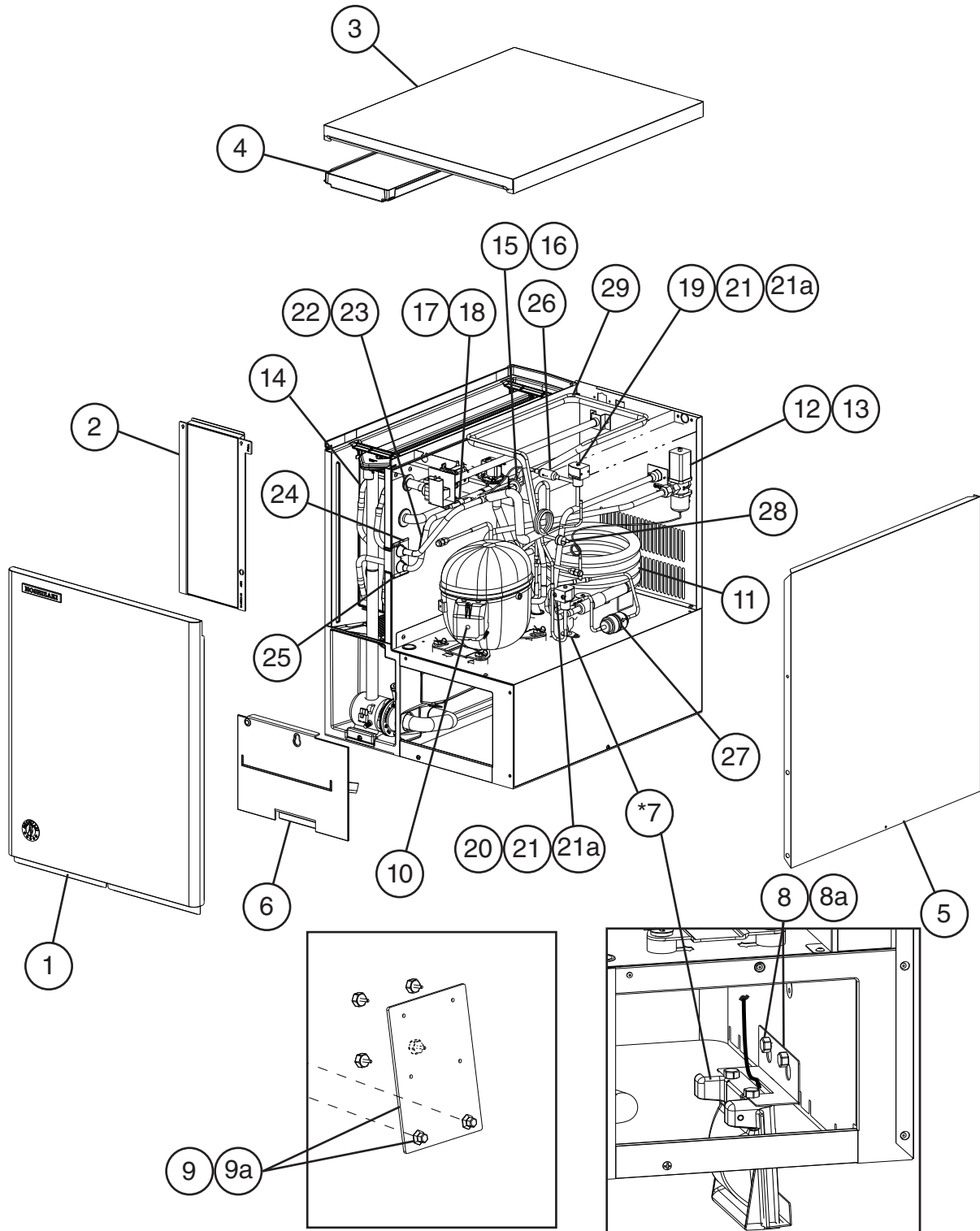

1Title: A. Main Assembly and Refrigeration Circuit Model: KM-350MWJ, KM-520MWJ, KM-660MWJ											
Index No.	Description	Material or Model Number	Part Number	Required Number							
				H-0 to J-0	J-1 to L-0(J)	L-0(K)	L-1 L-2				
Main Assembly											
1	Front Panel		1A6158G02	1	1	1	1				
2	Front Insulation		3A9354G01	1	1	1	1				
3	Top Panel		1A4554-01	1	1	1	1				
4	Top Insulation		3A9353G01	1	1	1	1				
5	Right Side Panel		1A5480-01	1	1	1	1				
6	Base Cover		3A9771-01	1	1	1	1				
*7	Ultrasonic Bin Control	KM-350MWJ	4A6148G01	1	1	1	1				
		KM-520MWJ		1	1	1	1				
		KM-660MWJ		1	1	-	1				
	Mechanical Bin Control *See page 4 "Aux Code Break" for reworked units.	KM-660MWJ	2A8598G01			1	-				
8	Mechanical Bin Control Bracket	KM-660MWJ	3A8283-01			1	-				
8a	Thumbscrews	KM-660MWJ	415949G08			2	-				
9	Mechanical Bin Control Extention Bracket	KM-660MWJ	4A5046G01			1	-				
9a	Thumbscrews	KM-660MWJ	438220-01			6	-				
Refrigeration Circuit											
10	Compressor	KM-350MWJ	4A5090-01	1	1	1	1				
		KM-520MWJ	4A4479-01	1	1	1	1				
		KM-660MWJ	4A5158-01	1	1	1	1				
11	Condenser		3A7321-01	1	1	1	1				
12	Water Regulating Valve	KM-350MWJ	4A0911-08	1	1	1	1				
		KM-520MWJ		1	1	1	1				
		KM-660MWJ		4A0911-07	1	1	1	1			
13	Male Connector		4A1087-01	1	1	1	1				
14	Evaporator		1A4119G01	1	1	1	1				
15	Thermostatic Expansion Valve		4A4008-02	1	1	1	1				
16	Thermostatic Expansion Valve Cover		3A0944-01	1	1	1	1				
17	Thermostatic Expansion Valve Bulb Holder		3A0107-01	1	1	1	1				
18	Hose Clamp		443461-02	1	1	1	1				
19	Hot Gas Valve Body		4A3978-01	1	1	1	1				
20	Liquid Line Valve Body		4A3276-01	1	1	1	1				
21	Valve Coil		4A3277-01	2	2	2	2				
21a	Bolt		4A3277F01	2	2	2	2				
22	Thermistor		429006-03	1	1	1	1				
23	Thermistor Holder		427430-01	1	1	1	1				
24	Rubber Insulation A		3A9637-01	1	1	1	1				
25	Rubber Insulation B		3A9638-01	1	1	1	1				
26	Strainer		441569-02	1	1	1	1				
27	Drier		4A1113-01	1	1	1	1				
28	High-Pressure Switch		463180-05	1	1	1	1				
29	Heat Exchanger		2A8681G01	1	-						
			2A9117G01		1	1	1				

A. Main Assembly & Refrigeration Circuit
KM-520MRJ, KM-520MRJZ, KM-660MRJ, KM-660MRJZ
 H-0 to L-1

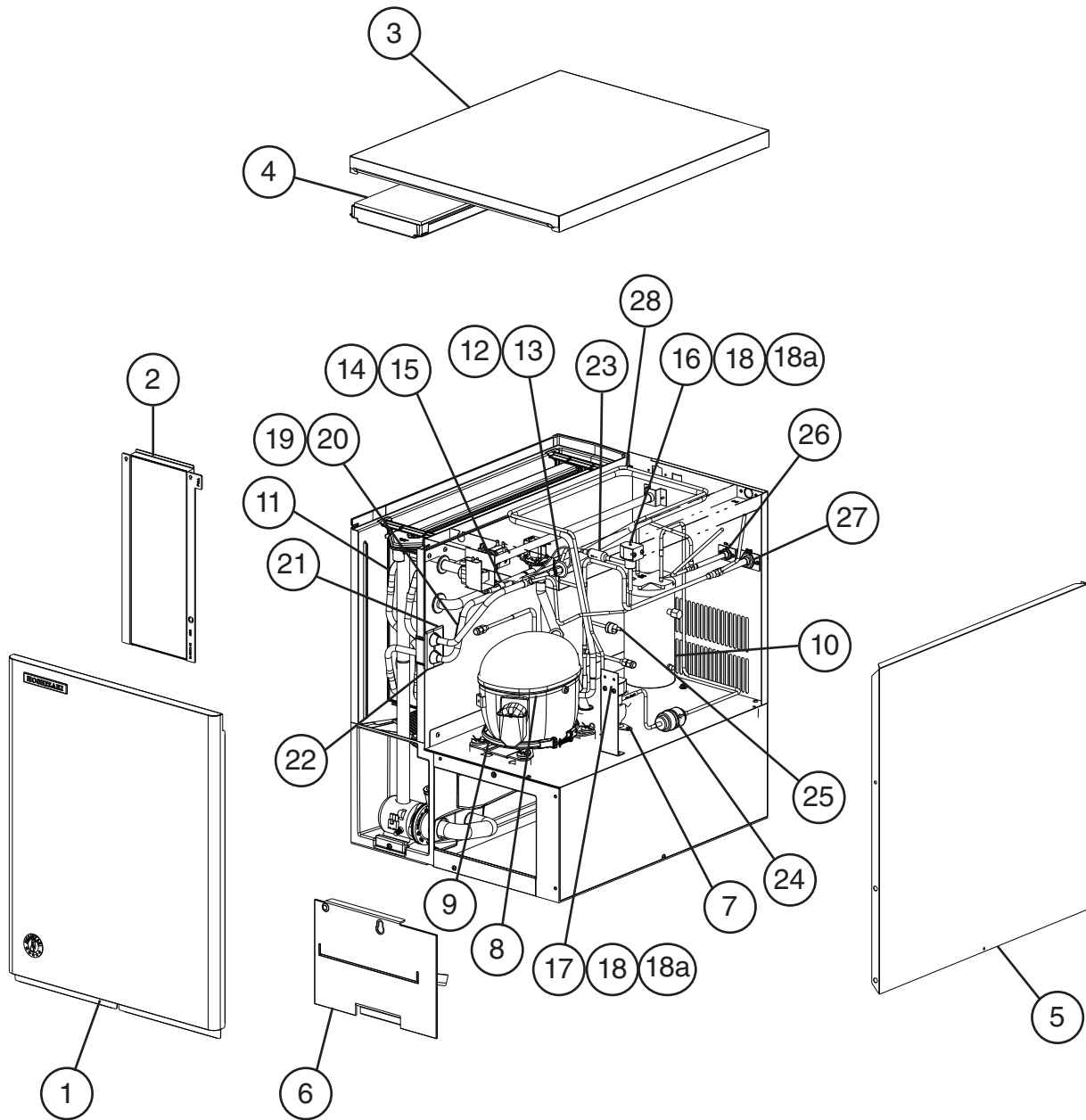

Title: A. Main Assembly & Refrigeration Circuit Model: KM-520MRJ, KM-520MRJZ, KM-660MRJ, KM-660MRJZ												
Index No.	Description	Material or Model Number	Part Number	Required Number								
				H-0 to J-0	J-1 to L-1							
Ice Cuber Assembly												
1	Front Panel		1A6158G02	1	1							
2	Front Insulation		3A9354G01	1	1							
3	Top Panel		1A4554-01	1	1							
4	Top Insulation		3A9353G01	1	1							
5	Right Side Panel		1A5480-01	1	1							
6	Base Cover		3A9771-01	1	1							
7	Ultra Sonic Bin Control		4A6148G01	1	1							
Refrigeration Circuit												
8	Compressor	KM-520MRJ KM-520MRJZ	4A4479-01	1	1							
		KM-660MRJ KM-660MRJZ	4A5158-01	1	1							
9	Crankcase Heater		4A5091-01	1	1							
10	Receiver Tank		4A6212-01	1	1							
11	Evaporator		1A4119G01	1	1							
12	Thermostatic Expansion Valve		4A4008-02	1	1							
13	Thermostatic Expansion Valve Cover		3A0944-01	1	1							
14	Thermostatic Expansion Valve Bulb Holder		3A0107-01	1	1							
15	Hose Clamp		443461-02	1	1							
16	Hot Gas Valve Body		4A3978-01	1	1							
17	Liquid Line Valve Body		4A3276-01	1	1							
18	Valve Coil		4A3277-01	2	2							
18a	Bolt		4A3277F01	2	2							
19	Thermistor		429006-03	1	1							
20	Thermistor Holder		427430-01	1	1							
21	Rubber Insulation A		3A9637-01	1	1							
22	Rubber Insulation B		3A9638-01	1	1							
23	Strainer		441569-02	1	1							
24	Drier		4A1113-01	1	1							
25	High-Pressure Switch		463180-01	1	1							
26	Liquid Line Coupling		4A3972G01	1	1							
27	Discharge Line Coupling		434136G01	1	1							
28	Heat Exchanger		2A8681G01	1	-							
			2A9117G01		1							

B. Water Circuit

KM-350M_J, KM-520M_J(Z), KM-660M_M_J(Z)

H-0 to L-2

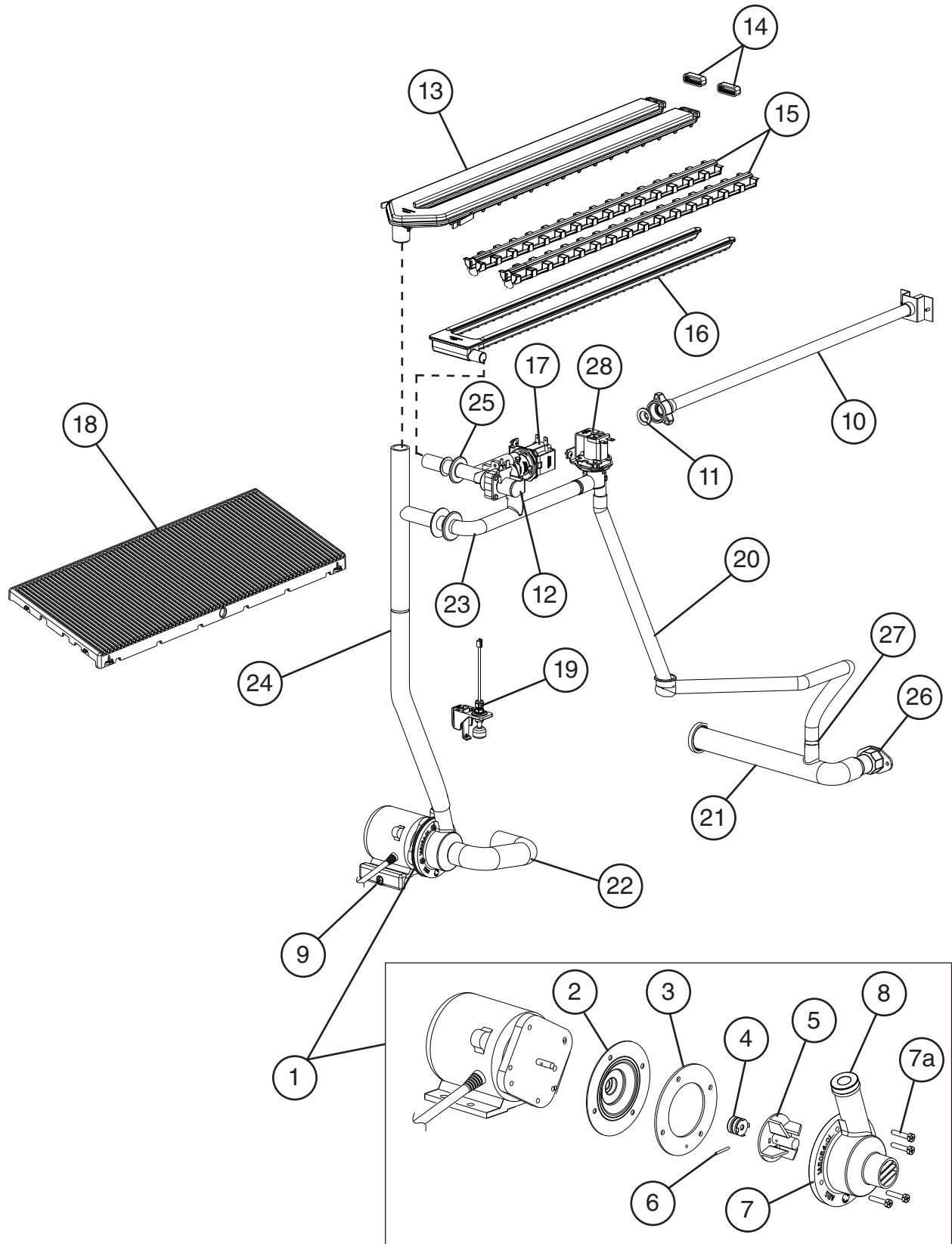

Title: B. Water Circuit Model: KM-350M_J, KM-520M_J(Z), KM-660M_J(Z)

Index No.	Description	Material or Model Number	Part Number	H-0 to L-2	Required Number									
1	Pump Motor Assembly (include items 2 through 8)		3A9728A01	1										
2	Pump Flange		3A2988-01	1										
3	Pump Gasket		4A2974-01	1										
4	Mechanical Seal		465627-01	1										
5	Impeller		433522-01	1										
6	Pin		4A0648-01	1										
7	Pump Housing		1A5054-01	1										
7a	Screw	4x20,	4A3871-01	4										
8	Reducing Pipe		4A6178-01	1										
9	Pump Motor Bracket		1A4670-01	1										
10	Water Supply Pipe		4A5216G04	1										
11	Rubber Gasket		413854-03	1										
12	Inlet Water Valve		3U0111-03	1										
13	Spray Tube		1A4571G01	1										
14	Plug		4A6394-01	2										
15	Spray Guide		1A4581-01	2										
16	Water Supply Tube		1A4572G01	1										
17	Cleaning Valve		4A5745-01	1										
18	Cube Guide		1A4568-01	1										
19	Float Switch		4A7080G01	1										
20	Silicone Hose	L= 140mm	7730-1114	1										
21	Drain Hose		1A4579-01	1										
22	Suction Hose		433466-01	1										
23	Bypass Hose		3A9544-01	1										
24	Water Hose		2A8823G01	1										
25	Water Supply Tee		3A9429-01	1										
26	Drain Fitting		4A5528-02	1										
27	Joint Pipe		4A6286-01	1										
28	Drain Valve		4A5745-03	1										

C. Control Box Assembly
KM-350M_J, KM-520M_J(Z), KM-660M_J(Z)
 H-0 to L-2

***K Control Board with
 Ultrasonic Sensor
 Control Board**

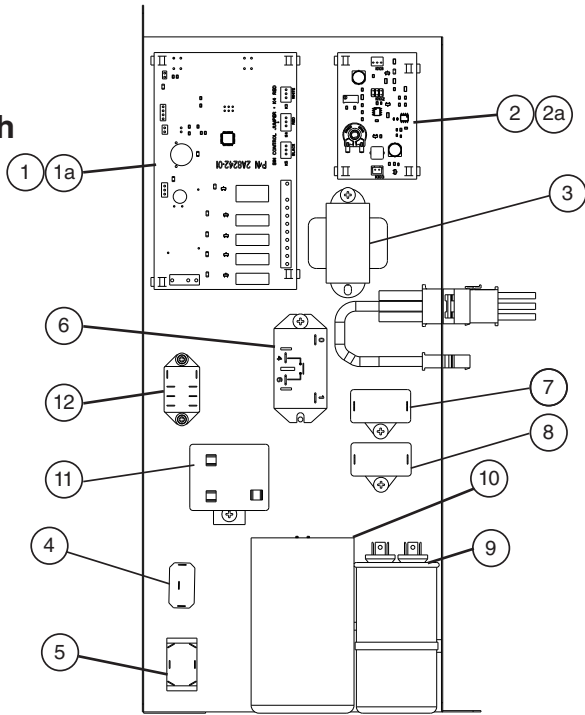

***K+ Control Board**

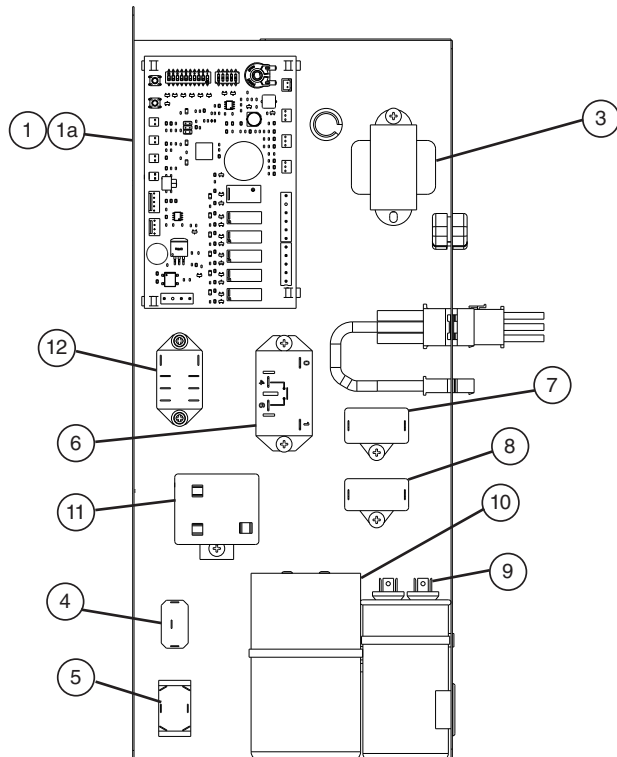

Title: C. Control Box Assembly Model: KM-350M_J, KM-520M_J(Z), KM-660M_J(Z)											
Index No.	Description	Material or Model Number	Part Number	Required Number							
				H-0 to J-0	J-1 to L-0(J)	L-0(K)	L-0(L) to L-1(J)	L-1(K)	L-1(L) to L-2		
1	Control Board *See page 4 "Aux Code Break."	KM-350MAJ	2A8242-02	1	1	1	1	*1	-		
		KM-520MAJ		1	1	*1	-				
		KM-660MAJ		1	1	*1	-				
		KM-350MWJ		1	1	-					
		KM-520MWJ		1	1	-					
		KM-660MWJ		1	1	*1	-				
		KM-520MRJ		1	1	-					
		KM-660MRJ		1	1	-					
		KM-350MAJ	2A9678-01					*1	1		
		KM-520MAJ				*1	1	1	1		
		KM-660MAJ				*1	1	1	1		
		KM-350MWJ				1	1	1	1		
		KM-520MWJ				1	1	1	1		
		KM-660MWJ						*1	1	1	1
KM-520MRJZ			1	1	1	1	1	1			
KM-660MRJZ			1	1	1	1	1	1			
1a	Control Board Support		4A0336-03	4	4	4	4	4	4		
2	Ultrasonic Bin Control Board *See page 4 "Aux Code Break."	KM-350MAJ	4A6149-01	1	1	1	1	*1	-		
		KM-520MAJ		1	1	*1	-				
		KM-660MAJ		1	1	1	-				
		KM-350MWJ		1	1	-					
		KM-520MWJ		1	1	-					
		KM-660MWJ		1	1	*1	-				
		KM-520MRJ		1	1	-					
		KM-660MRJ		1	1	-					
2a	Control Board Support		4A0336-03	4	4	-					
3	Control Transformer		3A0172-01	1	1	1	1	1			
4	Control Switch		4A0985-01	1	1	1	1	1			
5	Mode Switch		4A6232-01	1	1	1	1	1			
6	Compressor Relay		4A3140-01	1	1	1	1	1			
7	Pump Motor Capacitor	5.5MFD, 250VAC	443192-03	1	-						
			4A6435-03		1	1	1	1			
8	Fan Motor Capacitor	KM-350MAJ KM-520MAJ KM-660MAJ	443192-02	1	-						
		5.0MFD, 250VAC	4A6435-02		1	1	1	1			
9	Run Capacitor	KM-350M_J KM-520M_J	3A2005-12	1	1	1	1	1			
		35MFD, 440VAC KM-660M_J KM-660MRJZ	3A2005-07	1	1	1	1	1			
		40MFD, 440VAC									

Title: C. Control Box Assembly Model: KM-350M_J, KM-520M_J(Z), KM-660M_J(Z)

Index No.	Description	Material or Model Number	Part Number	Required Number									
				H-0 to J-0	J-1 to L-0(J)	L-0(K)	L-0(L) to L-1(J)	L-1(K)	L-1(L) to L-2				
10	Start Capacitor	KM-350M_J KM-520M_J 243-292MFP 165VAC	3A0076-20	1	1	1	1	1					
		KM-660M_J KM-660MRJZ 243-292MFP 250VAC	3A0076-21	1	1	1	1	1					
11	Start Relay	KM-350M_J	4A1107-18	1	1	1	1	1					
		KM-520M_J	4A1107-11	1	1	1	1	1					
		KM-660M_J KM-660MRJZ	4A1107-20	1	1	1	1	1					
12	Relay X10=Crankcase Heater Relay	KM-520MRJ(Z) KM-660MRJ(Z)	406132-07	1	1	1	1	1	1				
13	In-Line Fuse Holder		4A6950-01	1	1	1	1	1	1				
14	Fuse		4A0893-07	1	1	1	1	1	1				
15	Wire Harness A		1A4291-02	1	1	1	1	1	1				
16	Wire Harness B		1A4292-01	1	1	1	1	1	1				
17	Wire Harness C	KM-520MRJ(Z) KM-660MRJ(Z)	1A5041-01	1	1	1	1	1	1				

D. Accessories & Labels

KM-350M_J, KM-520M_J(Z), KM-660M_J(Z)

H-0 to L-2

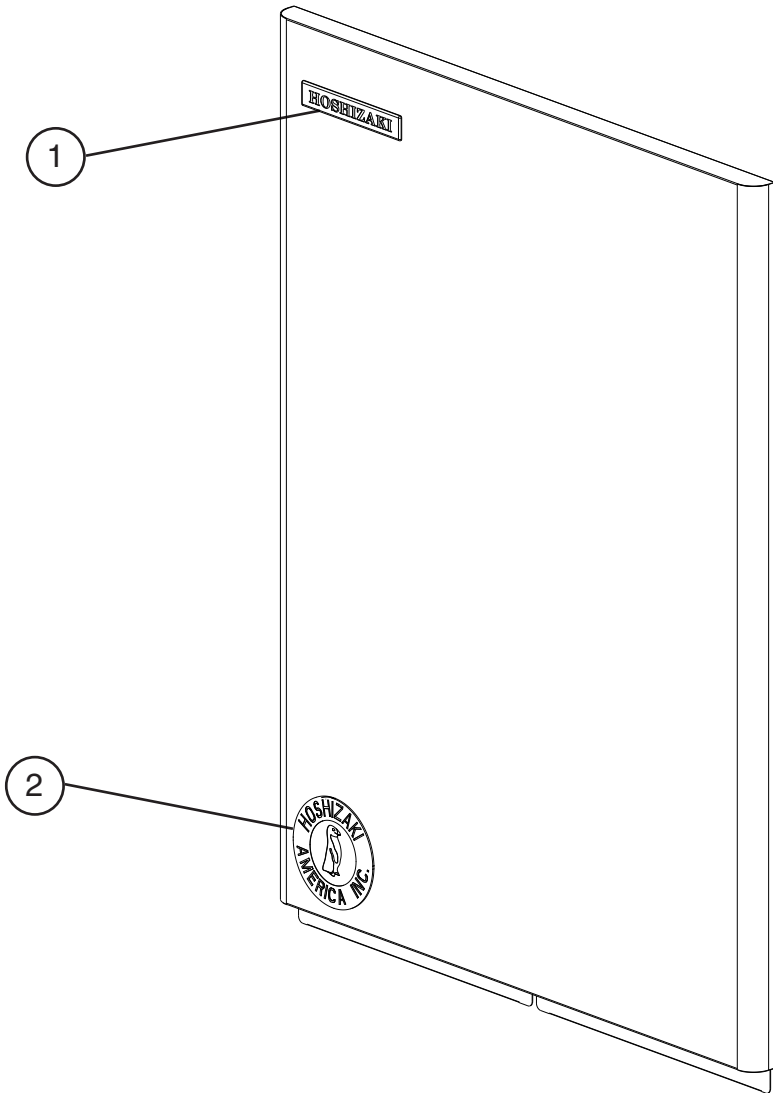

Title: D. Accessories & Labels Model: KM-350M_J, KM-520M_J(Z), KM-660M_J(Z)					Required Number								
Index No.	Description	Material or Model Number	Part Number	H-0 to L-2									
1	Hoshizaki Emblem		4A0560-01	1									
2	Penguin Label		475552L02	1									
3	Universal Brace		4A0363-01	2									
3a	Hex Head Bolt	5x12, SS	7B02-0512	2									



HOSHIZAKI

Parts List

Storage Bin

Models

B-250PF	B-300SF
B-300PF	B-500SF
B-500PF	B-700SF
B-700PF	B-800SF
B-800PF	B-900SF
B-900PF	BD-300SF
BD-300PF	BD-500SF
BD-500PF	



CONTENTS

Auxiliary Codes.....	3
Note About Ordering Parts	6
A. Storage Bin.....	7
B. Accessories & Labels	10

Auxiliary Codes

B-250PF

L-5 August 2001
M-5 February 2002
N-5 December 2002
P-5 December 2003
Q-5 December 2004
R-5 December 2005
S-5 January 2007
T-5 January 2008
U-5 January 2009
V-5 January 2010
A-5 January 2011
B-5 January 2012
C-5 January 2013
D-5 January 2014
E-5 January 2015
E-6 August 2015
F-5 January 2016
G-5 January 2014

B-300PF

L-5 July 2001
M-5 December 2001
N-5 December 2002
P-5 December 2003
Q-5 December 2004
R-5 December 2005
S-5 January 2007
T-5 January 2008
U-5 January 2009
V-5 January 2010
A-5 January 2011
B-5 January 2012
C-5 January 2013
D-5 January 2014
D-6 March 2014
E-5 January 2015
E-6 August 2015
F-5 January 2016
G-5 January 2017

BD-300PF

A-5 April 2011
D-5 April 2014
E-5 February 2015
E-6 October 2015
F-5 May 2016
G-5 January 2017

B-500PF

L-5 June 2001
M-5 December 2001
N-5 December 2002
P-5 December 2003
Q-5 December 2004
R-5 December 2005
S-5 January 2007
T-5 January 2008
U-5 January 2009
V-5 January 2010
A-5 January 2011
B-5 January 2012
C-5 January 2013
D-5 January 2014
E-5 January 2015
E-6 August 2015
F-5 January 2016
G-5 January 2017

BD-500PF

A-5 July 2011
B-5 April 2015
C-5 April 2013
D-5 January 2014
E-5 January 2015
E-6 September 2015
F-5 February 2016
G-5 January 2017

B-700PF

L-5 June 2001
M-5 December 2001
N-5 December 2002
P-5 December 2003
Q-5 December 2004
R-5 December 2005
S-5 January 2007
T-5 January 2008
U-5 January 2009
V-5 January 2010
A-5 January 2011
B-5 January 2012
C-5 January 2013
D-5 January 2014
E-5 January 2015
E-6 August 2015
F-5 January 2016
G-5 January 2017

B-800PF

L-5 June 2001
M-5 December 2001
N-5 December 2002
P-5 December 2003
Q-5 December 2004
R-5 December 2005
S-5 January 2007
T-5 January 2008
U-5 January 2009
V-5 January 2010
A-5 January 2011
B-5 January 2012
C-5 January 2013
D-5 January 2014
E-5 January 2015
E-6 August 2015
F-5 January 2016
G-5 January 2017

B-900PF

L-5 June 2001
M-5 December 2001
N-5 December 2002
P-5 January 2004
Q-5 December 2004
R-5 December 2005
S-5 January 2007
T-5 January 2008
U-5 January 2009
V-5 January 2010
A-5 January 2011
B-5 January 2012
C-5 January 2013
D-5 January 2014
E-5 January 2015
E-6 August 2015
F-5 January 2016
G-5 January 2017

Auxiliary Codes Continued

B-300SF

L-5 June 2001
M-5 December 2001
N-5 December 2002
P-5 December 2003
Q-5 December 2004
R-5 December 2005
S-5 January 2007
T-5 January 2008
U-5 January 2009
V-5 February 2010
A-5 January 2011
B-5 January 2012
C-5 January 2013
D-5 January 2014
D-6 February 2014
E-5 January 2015
E-6 August 2015
F-5 January 2016
G-5 January 2017

BD-300SF

A-5 April 2011
D-5 April 2014
E-5 February 2015
E-6 October 2015
F-5 October 2016
G-5 February 2017

B-500SF

L-5 June 2001
M-5 December 2001
N-5 December 2002
P-5 December 2003
Q-5 December 2004
R-5 December 2005
S-5 January 2007
T-5 January 2008
U-5 January 2009
V-5 January 2010
A-5 January 2011
B-5 January 2012
C-5 January 2013
D-5 January 2014
E-5 January 2015
E-6 August 2015
F-5 January 2016
G-5 January 2017

BD-500SF

A-5 April 2011
B-5 March 2012
C-5 May 2013
D-5 February 2014
E-5 May 2015
E-6 August 2015
F-5 June 2016
G-5 March 2017

B-700SF

L-5 September 2001
M-5 December 2001
N-5 December 2002
P-5 December 2003
Q-5 December 2004
R-5 December 2005
S-5 January 2007
T-5 January 2008
U-5 January 2009
V-5 January 2010
A-5 January 2011
B-5 January 2012
C-5 January 2013
D-5 January 2014
E-5 January 2015
E-6 August 2015
F-5 January 2016
G-5 January 2017

B-800SF

L-5 September 2001
M-5 December 2001
N-5 December 2002
P-5 December 2003
Q-5 December 2004
R-5 December 2005
S-5 January 2007
T-5 January 2008
U-5 January 2009
V-5 January 2010
A-5 January 2011
B-5 January 2012
C-5 January 2013
D-5 January 2014
E-5 January 2015
E-6 August 2015
F-5 January 2016
G-5 January 2017

Auxiliary Codes Continued

B-900SF

L-5	June 2001
M-5	December 2001
N-5	January 2003
P-5	December 2003
Q-5	December 2004
R-5	December 2005
S-5	January 2007
T-5	January 2008
U-5	January 2009
V-5	January 2010
A-5	January 2011
B-5	January 2012
C-5	January 2013
D-5	January 2014
E-5	January 2015
E-6	August 2015
F-5	January 2016
G-5	January 2017

Auxiliary Code Breakdown

The auxiliary code is the first two characters in the serial number. The first character indicates the year. Years progress or regress in alphabetical order. The series runs from "A" through "V" and the letters "I" and "O" are skipped. The second character indicates significant part changes within a year. Base is "5" and this number advances for each change. In cases where there is a letter in parentheses, this designates the month. This is the last character in the serial number. The series runs from "(A)" through "(M)" and the letter "(I)" is skipped. This designation is only included when identifying a parts change within an auxiliary code.

Note About Ordering Parts

Most assemblies cannot be ordered as complete units; parts in the assemblies generally must be ordered separately.

A. Storage Bin

B-___PF, BD-___PF, B-___SF, BD-___SF

L-5 to G-5

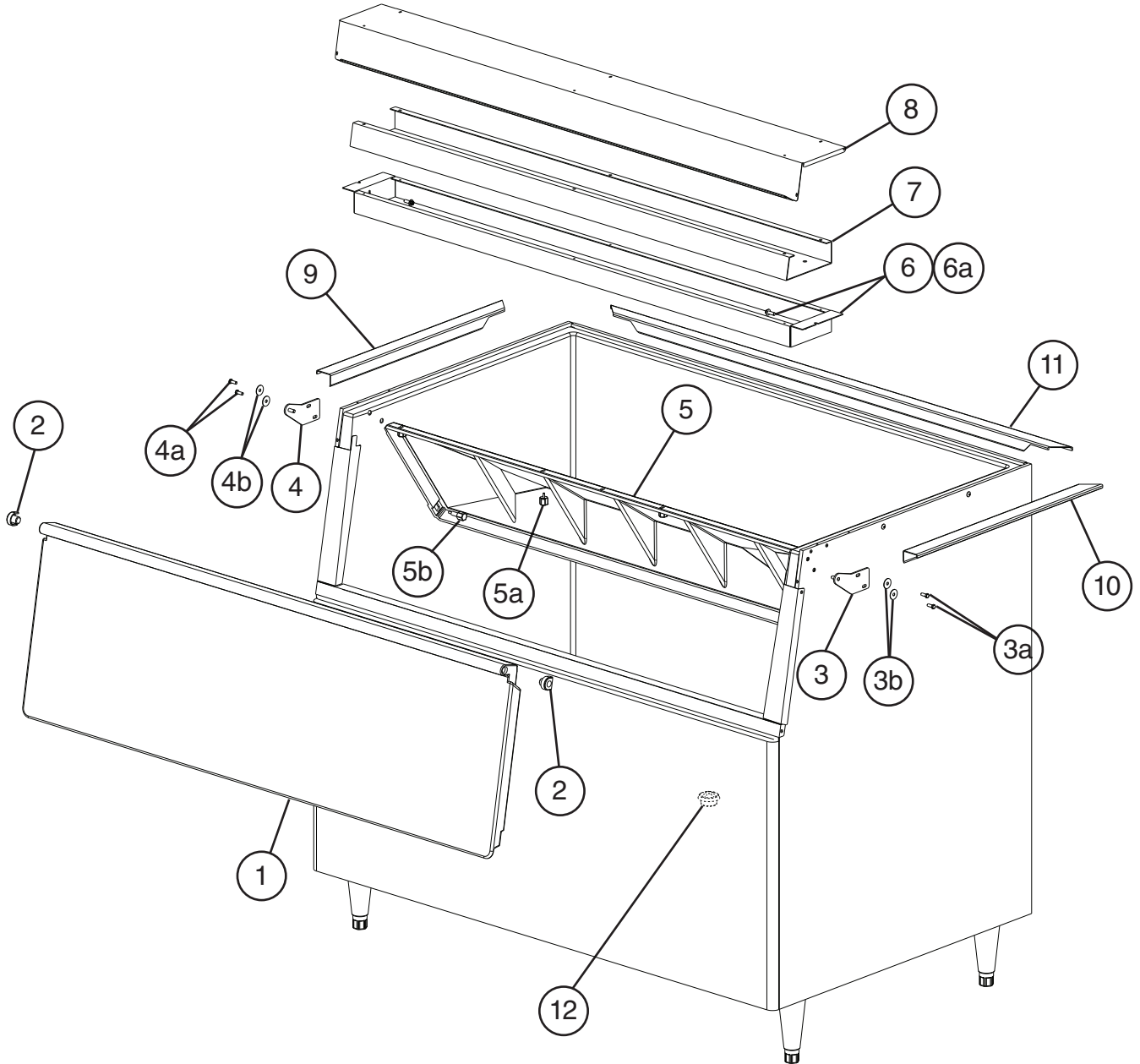

Model Shown: B-900PF

Title: A.Storage Bin Model: B-___PF, BD-___PF, B-___SF, BD-___SF												
Index No.	Description	Material or Model Number	Part Number	Required Number								
				L-5 to U-5 (C)	U-5 (D) to V-5	A-5 to D-5	D-6 to G-5					
1	Bin Door (includes item 2)	B-250PF	HS-2144	1	1	1	1					
		B-500PF/SF										
		BD-500PF/SF				1	1					
		B-300PF/SF	HS-2143	1	1	1	1					
		BD-300PF/SF				1	1					
		B-700PF/SF	HS-2140	1	1	1	1					
B-800PF/SF	HS-2141	1	1	1	1							
B-900PF/SF	HS-2142	1	1	1	1							
2	Bushing		4A2582-01	2	-							
			4A3914-01		2	2	2					
3	Right Hinge		3A0105G01	1	-							
			3A3725G01		1	1	1					
3a	Hex Head Bolt	5x14, SS	7B02-0514	2	2	2	2					
3b	Washer		4A0198-01	2	2	2	2					
4	Left Hinge		3A0106G01	1	-							
			3A3726G01		1	1	1					
4a	Hex Head Bolt	5x14, SS	7B02-0514	2	2	2	2					
4b	Washer		4A0198-01	2	2	2	2					
5	Baffle	B-250PF	104322-01	1	1	1	1					
		B-500PF/SF										
		BD-500PF/SF				1	1					
		B-300PF/SF	104391-01	1	1	1	1					
		BD-300PF/SF				1	1					
		B-700PF/SF	104323-01	1	1	1	1					
B-800PF/SF	105012-01	1	1	1	1							
B-900PF/SF	104324-02	1	1	1	1							
5a	Thumbscrew	B-250PF	415949G12	2	2	2	2					
		B-300PF/SF										
		BD-300PF/SF										
		B-500PF/SF										
BD-500PF/SF												
B-700PF/SF			3	3	3	3						
B-800PF/SF			4	4	4	4						
B-900PF/SF												
5b	Thumbscrew		434168G01	2	2	2	2					
6	Front Frame	B-250PF	3A0420-01	1	1	1	1					
		B-500PF/SF										
		B-300PF/SF	3A8180-01				1					
		BD-300PF/SF	3A6594-01			1	1					
		BD-500PF/SF	3A6594-02			1	1					
		B-700PF/SF	3A0446-01	1	1	1	1					
B-800PF/SF	3A0447-01	1	1	1	1							
B-900PF/SF	3A0447-02	1	1	1	1							
6a	Hex Head Tapping Screw		7B03I0834	2	2	2	2					

Title: A.Storage Bin Model: B-___PF, BD-___PF, B-___SF, BD-___SF											
Index No.	Description	Material or Model Number	Part Number	Required Number							
				L-5 to U-5 (C)	U-5 (D) to V-5	A-5 to D-5	D-6 to G-5				
7	Front Frame Cover	B-250PF B-500PF/SF	324625-01	1	1	1	1				
		B-300PF/SF	324617-01	1	1	1	1				
		B-700PF/SF	3A0155-01	1	1	1	1				
		B-800PF/SF	325510-01	1	1	1	1				
		B-900PF/SF	324619-01	1	1	1	1				
8	Top Cover	B-250PF B-500PF/SF	3A0157-01	1	1	1	1				
		B-300PF/SF	3A0156-01	1	1	1	-				
			3A8189-01				1				
		BD-300PF/SF	3A6538-01			1	1				
		BD-500PF/SF	3A6537-01			1	1				
		B-700PF/SF	3A0158-01	1	1	1	1				
		B-800PF/SF	2A0106-01	1	1	1	1				
B-900PF/SF	2A0107-01	1	1	1	1						
9	Right Bin Cap	B-250PF B-300PF/SF B-500PF/SF B-700PF/SF B-800PF/SF B-900PF/SF	3A7473-01				1				
10	Left Bin Cap	B-250PF B-300PF/SF B-500PF/SF B-700PF/SF B-800PF/SF B-900PF/SF	3A7474-01				1				
11	Back Bin Cap	B-250PF B-500PF/SF	3A7475-02				1				
		B-300PF/SF	3A7475-01				1				
		B-700PF/SF	3A7475-03				1				
		B-800PF/SF	3A7475-05				1				
		B-900PF/SF	3A7475-04				1				
12	Drain Cap		322015-01	1	1	1	1				

B. Accessories & Labels

B-___PF, BD-___PF, B-___SF, BD-___SF

L-5 to G-5

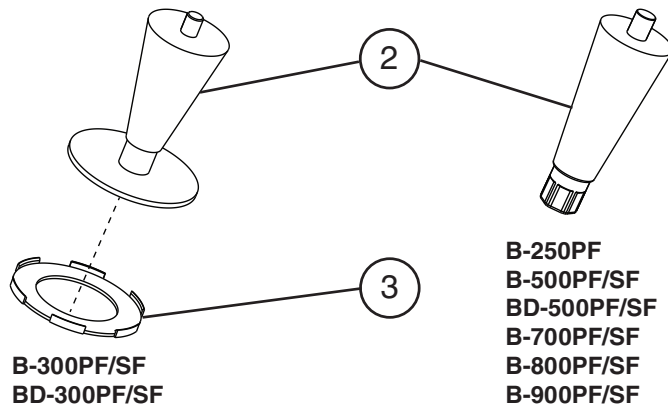
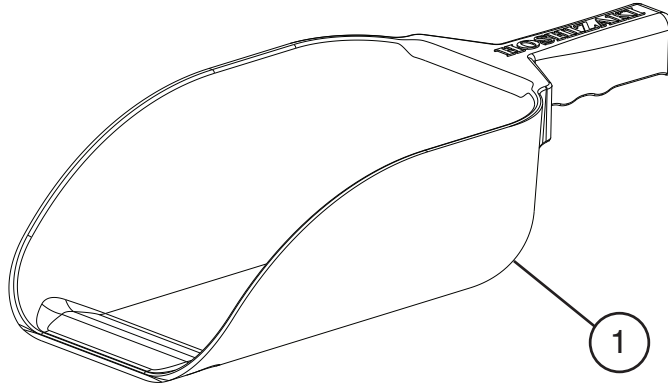

Title: B. Accessories & Labels Model: B-___PF, BD-___PF, B-___SF, BD-___SF										
Index No.	Description	Material or Model Number	Part Number	L-5 to G-5	Required Number					
1	Scoop		4A2246-01	1						
2	Leg	B-300PF/SF BD-300PF/SF	4A2526-01	4						
		B-250PF B-500PF/SF BD-500PF/SF B-700PF/SF B-800PF/SF B-900PF/SF	4A2525-01	4						
3	Leg Protector	B-300PF/SF BD-300PF/SF	3A0134-01	4						