

MANUAL GREASE TRAPS



GGXM-25

MANUAL GREASE TRAP WITH SOLIDS FILTER

**25 GPM - 50+
Pounds Grease
Capacity**

- 304 Stainless Steel for superior hygiene and quality
- ASME 112.14.3 Approved
- Integral Flow Control
- Unique Dry Strainer design with front access
- Fully sealed lid with quick access release clips
- "Plumb Tidy" pipes fitted at back of unit
- Uni-directional flow
- De-sludge Valve

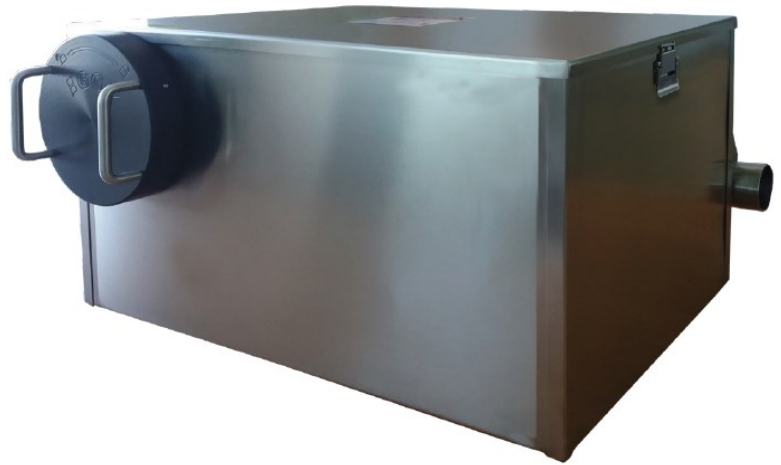

ASME
A112.14.2

STAINLESS STEEL CONSTRUCTION

Grease and Solids Separation for Pot Sinks, Pre-Rinse
and Multi Compartment Sinks



New Strainer Basket Design.
The basket is positioned above water level, allowing trapped solid to drip. It is lightweight making it easier to use.



New basket front position
facilitates installations in confined spaces thus allowing the use of bigger models when needed.



New lid closure gasket,
secures a better seal.



Multiple inlet outlet connection,
positioned at the back facilitates the installation process.

info@greaseguardian.com
www.greaseguardianusa.com

**Call Free
800-677-7861**

TECHNICAL DETAILS

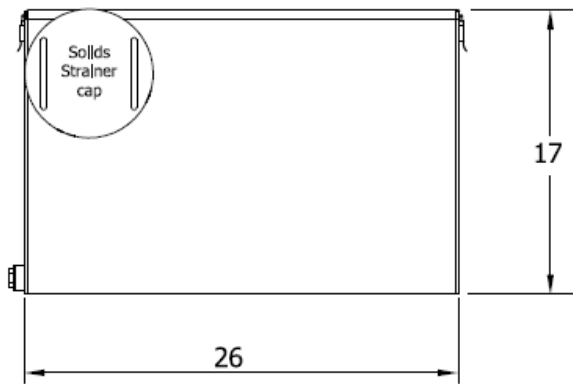

FRONT VIEW

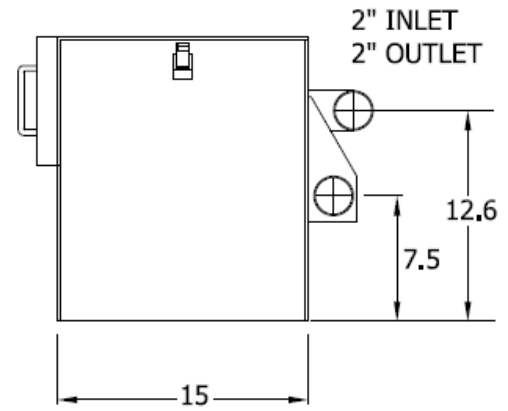

END VIEW

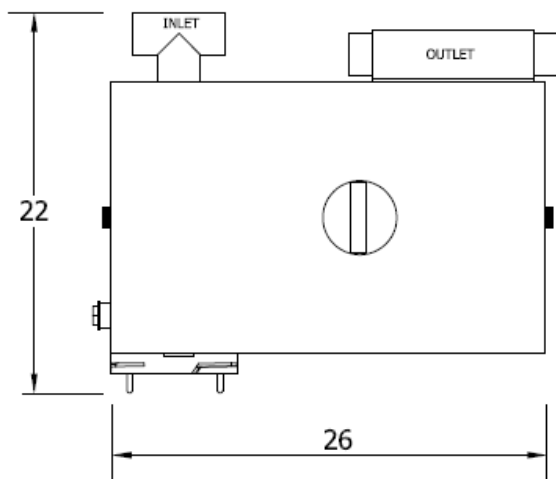

TOP VIEW

GGXM STANDARD FEATURES

- 10 Year Warranty
- 16 Gauge stainless steel welded tank
- Fully sealed air tight system
- Universal flow direction
- Dry solids strainer
- Integral flow control
- Integral gas trap



TECHNICAL DATA

WEIGHT	58 pounds
MATERIAL	304 Stainless steel
INTERIOR	304 Stainless steel
FLOWRATE	25 gallons per minute
GREASE RETENTION	50+ pounds
SOLIDS STRAINER CAPACITY	6.6 pounds
TANK CAPACITY	16 gallons

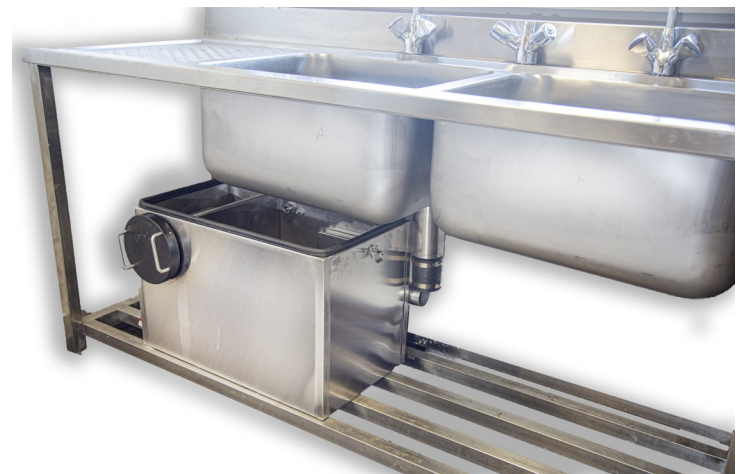

info@greaseguardian.com
www.greaseguardianusa.com
800-677-7861