

SERVER

• E S S E N T I A L S •

Toppi, g Warmers Single and Twin Merchandisers

SPECIFICATION SHEET



FAST FACTS

EZ-Topper® Warmers serve up to 98% of fudge or caramel topping from 48 oz pouches with a 16 mm center fitment in a 1 oz max serving that can be reduced in 1/8 oz increments

APPLICATIONS

- Ideal for self-serve dessert stations as tamper-resistant packaging brings peace of mind
- High-volume operations look, g to optimize downtime, g cha, geouts
- Lower-volume or sporadic-use operations serving toppings over a extended period of time

DETAILS

- Promote dessert consistency with portion control; 1 oz pump serving is adjustable in 1/8 oz increments
- Dispense more servings with eco-friendly pouched toppings; dispense; deliver up to 98% evacuation, and create 97% less packaging waste than cans
- Minimize downtime, g cha, geouts – twin models dispense from one pouch while pre-heating a second, reserve



85899



85920

85790



Sealed, sanitary system keeps topping safe and avoids product degradation; containment simplifies cleanup by keeping pump exterior clean

EZ-Topper® Warmers use 48 oz topping pouches with a 16-mm center fitment, currently packaged by:

- Ghirardelli® Chocolate Company
- Lyons Magnus
- Masterson Company



Adjustable thermostat heats and holds temperature as topping depletes to avoid scorching

BACK

Purposefully made to last.

EZ-TOPPER® POUCHED TOPPING WARMER MODELS: EZT & EZT-S

Server EZ-Topper® Warmers accept 48 oz topping pouches with 16 mm center fitment and are available with and without room to pre-heat a reserve pouch. Two warmers use individual temperature sensitive thermostats to control wrap-around heating elements for accurate heating and holding. Temperatures range from 100°F to 200°F. Pumps dispense 1 oz max stroke adjustable in 1/8 oz increments. Black knobs standard; units include black engraved replacement knobs ready for Caramel and Fudge. 72" electrical cord standard. NSF listed. C-UL-US listed. Two-year warranty.

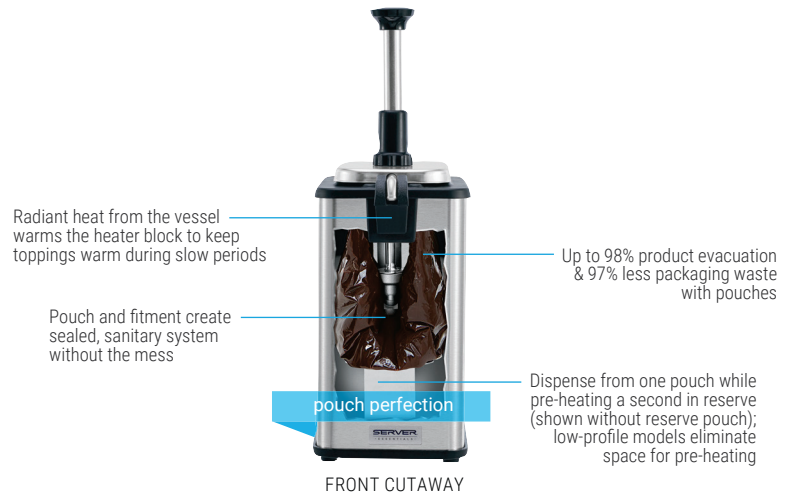
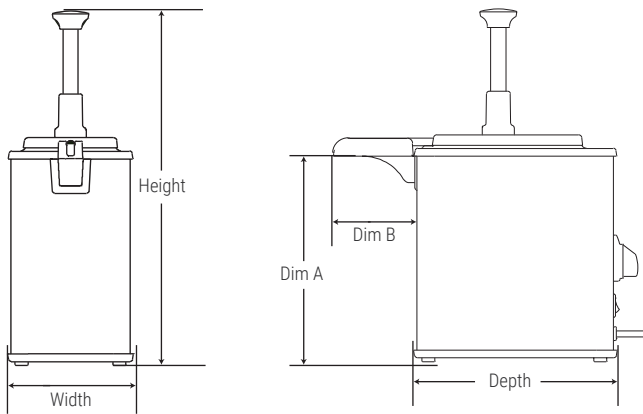

order amt	model/item	description	capacity	dims (H x W x D)	dim a	dim b	plug	voltage	watts/amps	weight
<input type="checkbox"/>	EZT-S 85790	single tall with heated spout	(2) 48 oz pouches; (1) active; (1) reserve	17 3/8" x 6" x 9 5/8"	10 1/4"	3 7/8"			200W 1.7A	14 lb
<input type="checkbox"/>	EZT 85899	twin tall with heated spout	(4) 48 oz pouches; (2) active; (2) reserve	17 3/8" x 11 7/8" x 9 5/8"	10 1/4"	3 7/8"		120AC	400W 3.3A	26 lb
<input type="checkbox"/>	EZT 85920	twin short with heated spout	(2) 48 oz pouches	13 15/16" x 11 7/8" x 9 5/8"	6 13/16"	3 7/8"			300W 2.5A	23 lb

RELATED PRODUCTS

SLIMLINE™ DRY FOOD DISPENSERS

SlimLine™ Dry Food Dispensers display and dispense preset portions of up to (4) candies, toppings, or mix-ins in less than 13" of wall space. Control costs with precise portion control; color-coded trays identify serving size. Stands are available for countertop dispensing.



DECREASE WASTE AND INCREASE WOW WITH EZ-TOPPER® POUCHED TOPPING WARMERS
 SERVER-PRODUCTS.COM | 800.558.8722 | 262.628.5600