



KM-1900S_J(Z)(3)

STACKABLE CRESCENT CUBER



KM-1900S_J(Z)(3)
10/24/22
Item # 13190

Item #: _____
 Project: _____
 Qty: _____
 AIA#: _____

W x D x H
48" x 27³/₈" x 36⁷/₁₆"

Shipping Dimensions
51³/₄" x 33" x 43"

KM Edge DESIGN

KM-1900SAJ ★

Air-Cooled 1 Phase
Shown on optional bin: B-900

KM-1900SWJ

Water-Cooled 1 Phase

KM-1900SRJZ ★

Remote Air-Cooled 1 Phase

KM-1900SAJ3 ★

Air-Cooled 3 Phase

KM-1900SWJ3

Water-Cooled 3 Phase

KM-1900SRJZ3 ★

Remote Air-Cooled 3 Phase



Features

▶ Individual crescent cube

▶ Stainless steel evaporator

▶ CycleSaver™ design

- Up to 1933 lbs. of ice production per 24 hours
- Stackable for 3866 lbs. per 24 hours ice production in the same floor space
- Durable stainless steel exterior
- Protected by H-Guard Plus Antimicrobial Agent
- EverCheck™ alert system
- R-404A Refrigerant

Available on Bins:

B-800 **B-1150SS** **B-1500SS** *Top kit may be required.*
B-900 **B-1300SS** **B-1650SS** *See Bin Spec Sheets.*

Warranty:

Valid in United States, Canada, Puerto Rico and U.S. Territories. Contact factory for warranty in other countries.

	Condenser	Model	ICE PRODUCTION		WATER USAGE			ELECTRICAL				Heat Rejection BTU/hr.	Refrigerant Charge Amount	Net / Ship Weight (lbs.)
			Air / Water Temp Lbs. per 24 hours	70° / 50°F 90° / 70°F	Potable Gal. per 100 lbs.	90° / 70°F	Condenser Gal. per 100 lbs.	90° / 70°F	kWh Used per 100 lbs.	90° / 70°F	Max. Fuse Size or HACR Circuit Breaker			
1 Phase	Air	KM-1900SAJ	1875	1675	19.0	N/A	3.90	30A	14.5A	208-230V/60/1	4*	21,200	4 lb. 10.1 oz.	390 / 415
	Water	KM-1900SWJ	1880	1875	21.0	85	3.20	30A	15.8A	208-230V/60/1	4*	21,500	3 lb. 1.4 oz.	390 / 415
	Remote	KM-1900SRJZ	1933	1700	19.0	N/A	3.90	30A	15.9A	208-230V/60/1	4*	24,200	13 lb. 12.5 oz. 21 lbs. 7.9 oz. ¹	390 / 415
3 Phase	Air	KM-1900SAJ3	1865	1675	19.0	N/A	3.90	20A	8.9A	208-230V/60/3	4	20,900	4 lb. 10.1 oz.	390 / 415
	Water	KM-1900SWJ3	1880	1875	21.0	85	3.20	20A	8.9A	208-230V/60/3	4	21,900	3 lb. 1.4 oz.	390 / 415
	Remote	KM-1900SRJZ3	1933	1700	19.0	N/A	3.90	20A	13.5A	208-230V/60/3	4	20,700	13 lb. 12.5 oz. 21 lbs. 7.9 oz. ¹	390 / 415

*If neutral is not available, transformer kit (HS-5030) is required. Refer to Instruction Manual for installation and electrical requirements.

¹with condenser
Power cord not included

KM Edge Cube Dimensions*

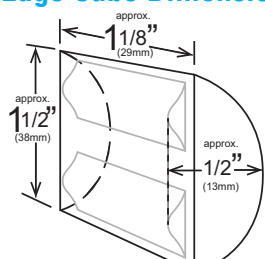

* approximate size in inches, image not to scale

Operating Limits

- Ambient Temp Range 45 - 100°F
- Water Temp Range 45 - 90°F
- Water Pressure 10 - 113 PSIG
- Voltage Range 187 - 253V

Service

- Panels easily removed and all components accessible for service.
- Allow 6" (15 cm) clearance at rear, sides, and top for proper air circulation and ease of maintenance/service.

Plumbing

- Icemaker Water Supply Line: Min. 3/8" Nominal ID Copper Water Tubing or Equivalent
- Icemaker Drain Line: Min. 3/4" Nominal ID Hard Pipe or Equivalent **Water-Cooled Model (Lines Must Be Independent of Icemaker)**
- Condenser Water Supply Line: Min. 3/8" Nominal ID Copper Water Tubing or Equivalent
- Condenser Drain/Return Line: Min. 3/8" Nominal ID Hard Pipe (open drain system) or Copper Water Tubing (closed loop system) or Equivalent

Water Filter

Please refer to water filter spec sheet for recommended configurations.

Hoshizaki reserves the right to change specifications without notice.



KM-1900S_J(Z)(3)

STACKABLE CRESCENT CUBER

KM-1900S_J(Z)(3)
10/24/22
Item # 13190

FRONT VIEW

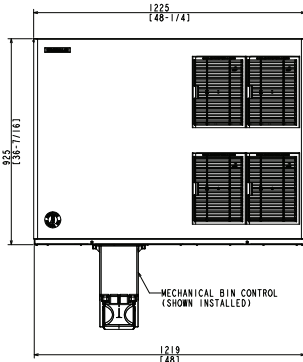

AIR-COOLED

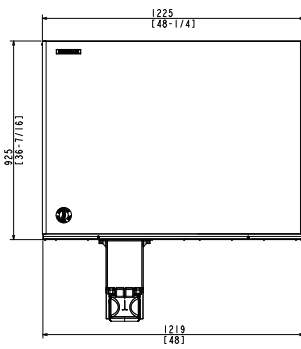

WATER-COOLED

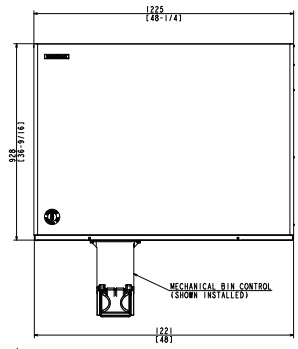

REMOTE AIR-COOLED

SIDE VIEW

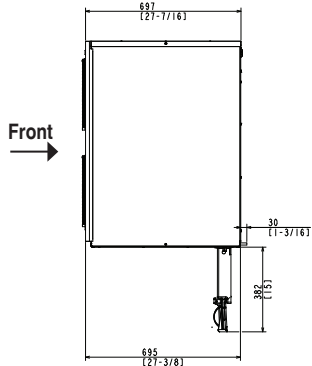

AIR-COOLED

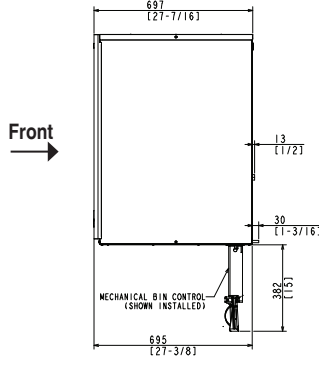

WATER-COOLED

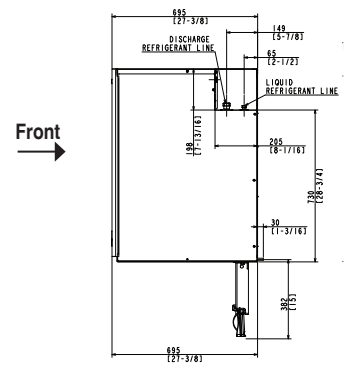

REMOTE AIR-COOLED

REAR VIEW

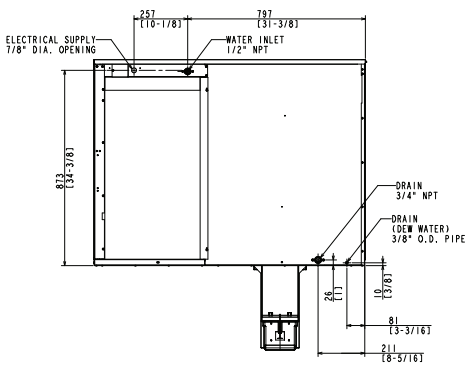

AIR-COOLED

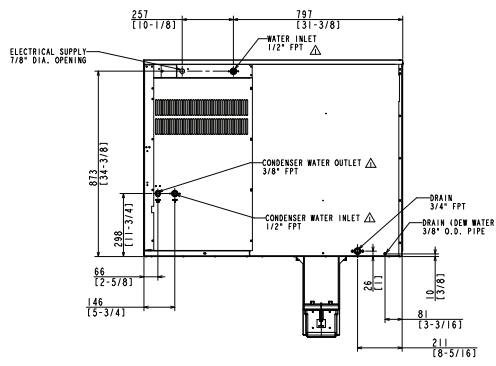

WATER-COOLED

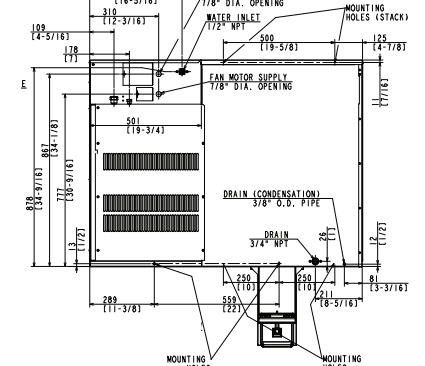

REMOTE AIR-COOLED

BOTTOM VIEW

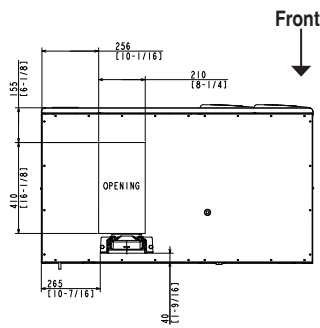

AIR-COOLED
WATER-COOLED

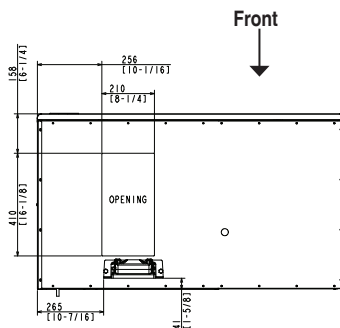

REMOTE AIR-COOLED

URC-22FZ Remote Condenser (Sold Separately)
(W x D x H) 46 3/8 X 14 1/16 X 40 1/2
For Use with KM-1900SRJ(Z)

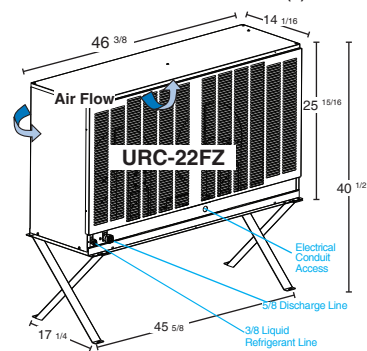

Braze Line Sets
(Sold Separately)
25' HS-5323
35' HS-5324
55' HS-5325



Voltage supply for the URC Remote Condenser is supplied from the Ice Maker. No additional circuit is required.