

# GRIDDLE STAND REFRIGERATOR

## Model: D48GN

Natural Refrigerant R-290 Model

## 48" Griddle Stand Refrigerator

Stainless steel exterior and interior, reinforced stainless steel work top with drip guard marine edge and stainless steel case back.



## Options and Accessories

(upcharge and lead times may apply)

|   |   |
|---|---|
| Flat top in lieu of marine edge               | Integral heat shield top                          |
| 16 gauge stainless steel top (flat or marine) | Cylinder locks                                    |
| Top extensions (flat or marine edge)          | Doors in lieu of drawers                          |
| Condensing unit on left (standard on right)   | Special electrical requirements (consult factory) |

Consult factory for other model configurations, options and accessories.

Project Name:

Model Specified:

Location:

Item No:

Quantity:

AIA #:

SIS #:

## Standard Model Features

### REFRIGERATION SYSTEM

Performance rated refrigeration system

Natural, environmentally safe, high efficiency R-290 refrigerant<sup>1</sup>

Automatic, hot gas condensate evaporator

Non-corrosive, plasticized fin evaporator coil

Easily serviceable, front slide outcondensing unit

### CABINET ARCHITECTURE

High density, non-CFC polyurethane foamed-in-place insulation

Easy glide, fully extendable drawers designed to hold 6" deep pans side-by-side

Smooth, polished chrome drawer handles

One-piece, snap in magnetic Santoprene™ drawer gaskets

Heavy duty drawer track with built in drawer safety clips

Drawers designed to hold 250 lb. capacity

(2) drawer pan divider bars\*

4" casters on support plates

\* Pans supplied by others

### MODEL FEATURES

Electronic controller with digital display & hi-low alarm

Off-cycle defrost

Front breathing

<sup>1</sup> R-290 refrigerant meets all federal and state regulatory requirements.

**Continental**  
Refrigerator

Toll-Free: 800-523-7138  
Phone: 215-244-1400  
Fax: 215-244-9579

539 Dunksferry Road  
Bensalem, PA 19020  
www.continentalrefrigerator.com

APPROVAL:

## Model Specifications

### DIMENSIONAL DATA

|  |                            |
|--|----------------------------|
| Net Capacity (cubic feet)                          | 9.0 (255 cu l)             |
| Width, Overall (inches)                            | 48 (1219 mm)               |
| Depth, Overall (inches)<br>(including handles)     | 35 $\frac{5}{16}$ (897 mm) |
| Height, Overall (inches)<br>(including 4" casters) | 26 $\frac{3}{8}$ (670 mm)  |
| Number of Drawers                                  | 2                          |

### REFRIGERANT DATA

|                             |               |
|-----------------------------|---------------|
| Condensing Unit Size (H.P.) | $\frac{1}{5}$ |
| Capacity (BTU per hour)*    | 1620          |

### ELECTRICAL DATA

|  |                     |
|--|---------------------|
| Voltage (International)                        | 115/60/1 (220/50/1) |
| Feed Wires (including ground)                  | 3                   |
| Total Amps (International)                     | 2.5 (1.9)           |
| 10 ft. Cord/Plug [attached]<br>(International) | Yes<br>(No)         |

### SHIPPING DATA

|                          |              |
|--------------------------|--------------|
| Weight (pounds)          | 450 (204 kg) |
| Height - Crated (inches) | 44 (1118 mm) |
| Width - Crated (inches)  | 64 (1626 mm) |
| Depth - Crated (inches)  | 39 (991 mm)  |

### DRAWER PAN DIVIDERS (supplied with model)

|          |                    |
|----------|--------------------|
| CM2-0764 | 2 (one per drawer) |
|----------|--------------------|

See drawer pan configurations on right (**pans not supplied**). For other drawer pan configurations, consult factory.

### TOP WEIGHT CAPACITY

|                                   |              |
|-----------------------------------|--------------|
| Max. Top Weight Capacity (pounds) | 775 (352 kg) |
|-----------------------------------|--------------|

\* Rating @ +25°F evaporator, 90°F ambient  
Figures in parentheses reflect metric equivalents rounded to the nearest whole unit.



Equipped with one NEMA-5-15P Plug  
(varies by country)

## Model Plan Views

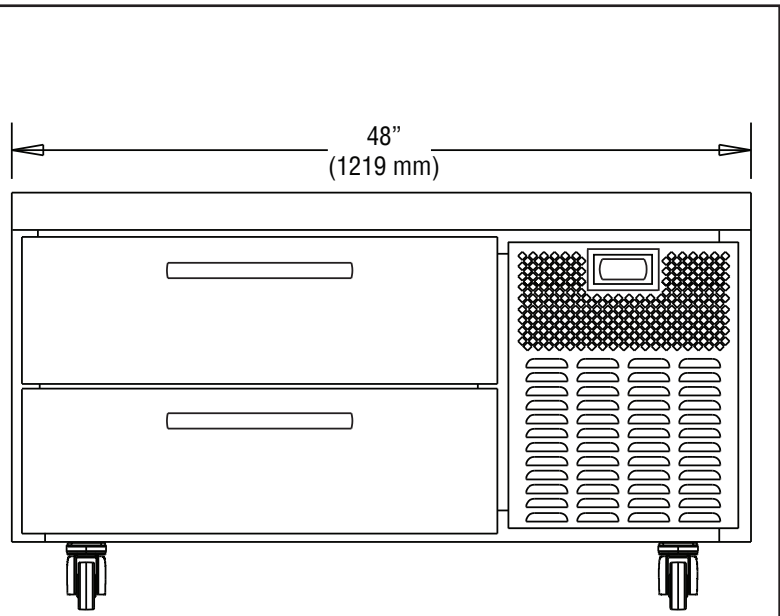

FRONT VIEW

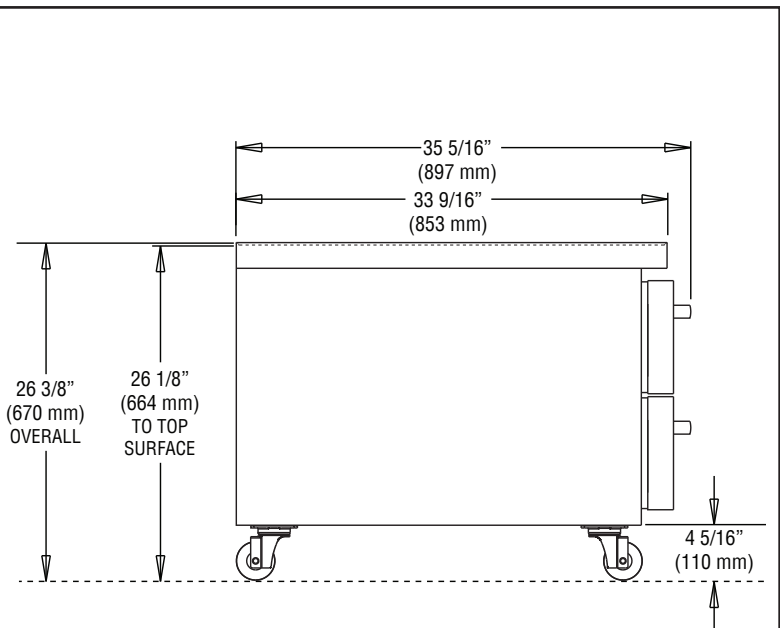

SIDE VIEW

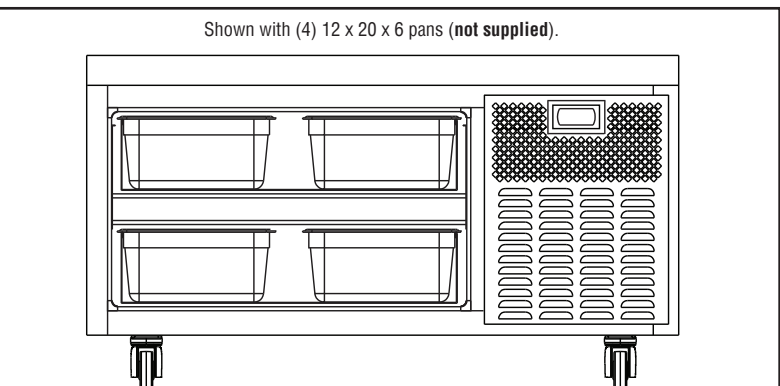

DRAWER PAN CONFIGURATION

**Continental**  
Refrigerator

Toll-Free: 800-523-7138  
Phone: 215-244-1400  
Fax: 215-244-9579

539 Dunksferry Road  
Bensalem, PA 19020  
[www.continentalrefrigerator.com](http://www.continentalrefrigerator.com)

Due to our continued efforts in developing innovative products, specifications subject to change without notice.



© Copyright 2021. Continental Refrigerator.  
A Division of National Refrigeration & Air Conditioning Products, Inc.

REVISED: 5/10/2022