

# DESIGNER LINE REFRIGERATOR

## Model: D2RN

Natural Refrigerant R-290 Model

*Designer Line*

## 2-Section Reach-In Refrigerator



ENERGY STAR® Qualified Commercial Refrigerator

**D2RN** - Stainless steel front, aluminum end panels and interior

**D2RNSA** - Stainless steel exterior, aluminum interior

**D2RNSS** - Stainless steel exterior and interior



## Options and Accessories

(upcharge and lead times may apply)

Stainless steel case back	Casters
Additional epoxy coated steel shelves	Pan slide assemblies
Chrome or stainless steel shelves	Custom laminates
Pass-thru (consult factory)	Special electrical req. (consult factory)
Shallow depth (consult factory)	<b>Correctional Facility Options</b>
Half doors	• One way security screws
Hinged glass door (consult factory)	• Locking hasp (lock not included)
Rehinging of doors (consult factory)	• Stainless steel mesh cover
Wine rack	• Coverless hinges

Consult factory for other model configurations, options and accessories.

**Continental**  
Refrigerator

Toll-Free: 800-523-7138  
Phone: 215-244-1400  
Fax: 215-244-9579

539 Dunksferry Road  
Bensalem, PA 19020  
[www.continentalrefrigerator.com](http://www.continentalrefrigerator.com)

Project Name:

Model Specified:

Location:

Item No:

Quantity:

AIA #:

SIS #:

## Standard Model Features

### REFRIGERATION SYSTEM

Self contained, performance rated "plug" refrigeration system

Natural, environmentally safe, high efficiency R-290 refrigerant<sup>1</sup>

Refrigeration system is readily accessible on top of cabinet, separate from the "food zone"

Automatic, hot gas condensate evaporator

Expansion valve system

### CABINET ARCHITECTURE

3" non-CFC polyurethane foam insulation

Smooth, polished chrome workflow door handles

Cam action, lift off hinges

Self-closing doors

Magnetic snap-in Santoprene™ door gaskets

Cylinder lock in each door

Heavy duty pilaster strips

Heavy duty, epoxy coated steel shelves

Adjustable 6" stainless steel legs

### MODEL FEATURES

LED interior lighting

Electronic controller with digital display & hi-low alarm

Off-cycle defrost

Top and side air distribution ducts

Cabinet upper side panels and refrigeration "plug" system can be removed and reinstalled at job site

<sup>1</sup> R-290 refrigerant meets all federal and state regulatory requirements.

APPROVAL:

## Model Specifications

### DIMENSIONAL DATA

Net Capacity (cubic feet)	50 (1416 cu l)
Width, Overall (inches)	52 (1321 mm)
Depth, Overall (inches) (including handles)	35 3/8 (899 mm)
Depth (inches) (less doors)	32 (813 mm)
Depth (inches) (doors open 90°)	55 1/2 (1410 mm)
Clear Door Width (inches)	19 3/8 (492 mm)
Clear Door Height (inches)	58 5/8 (1489 mm)
Height, Overall (inches) (including 6" legs)	83 1/4 (2115 mm)
Number of Doors	2
Number of Shelves	6
Shelf Area (square feet)	40.8 (3.8 sq m)
Tray Slide Capacity (per section)	24

### REFRIGERANT DATA

Condensing Unit Size (H.P.)	1/3+
Capacity (BTU per hour)*	2560

### ELECTRICAL DATA

Voltage (International)	115/60/1 (220/50/1)
Feed Wires (including ground)	3
Total Amps (International)	6.3 (4.3)
10 ft. Cord/Plug [attached] (International)	Yes (No)

### SHIPPING DATA

Height - Crated (inches)	85 1/2 (2172 mm)
Width - Crated (inches)	64 (1626 mm)
Depth - Crated (inches)	42 (1067 mm)
Volume - Crated (cubic feet)	133 (3766 cu l)
Weight Std - Crated (pounds)	448 (203 kg)
Weight SS - Crated (pounds)	470 (213 kg)

\* Rating @ +25°F evaporator, 90°F ambient  
Figures in parentheses reflect metric equivalents rounded to the nearest whole unit.



Equipped with one NEMA-5-15P Plug  
(varies by country)

## Model Plan Views

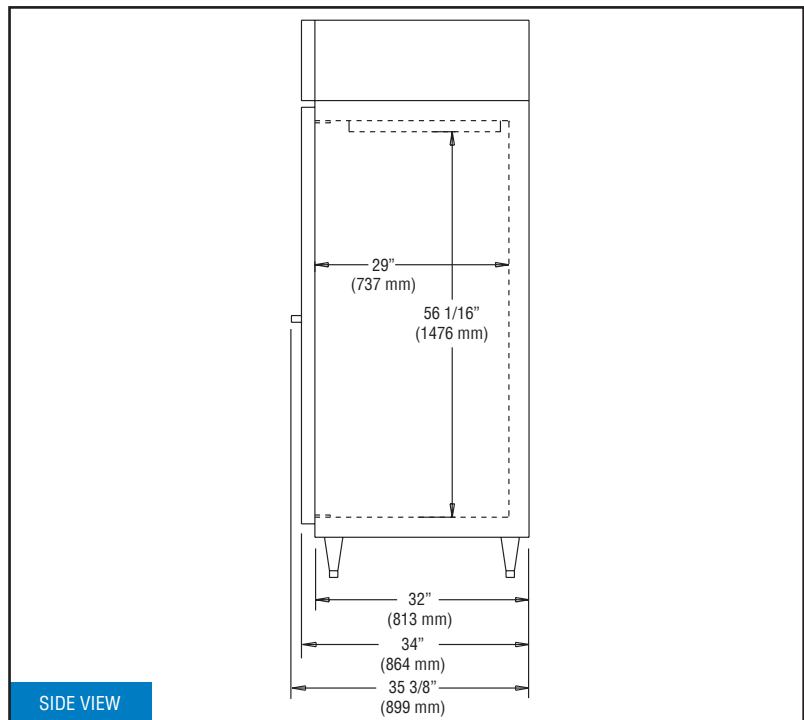
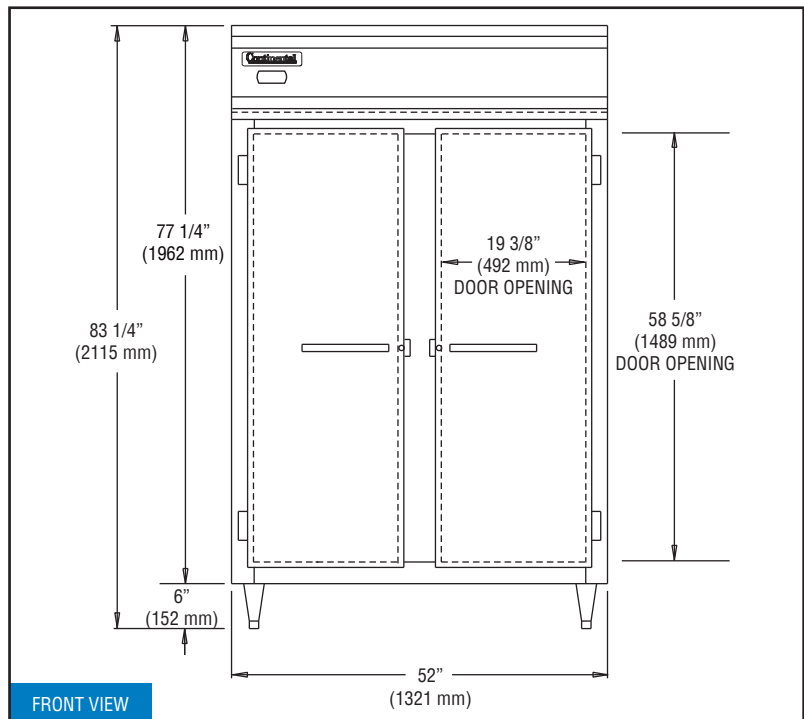

**IMPORTANT NOTE:** If the cabinet is located directly against a wall and/or under a low ceiling, a minimum clearance of 12" is required on top and 3" on sides and rear.

**Continental**  
Refrigerator

Toll-Free: 800-523-7138  
Phone: 215-244-1400  
Fax: 215-244-9579

539 Dunksferry Road  
Bensalem, PA 19020  
[www.continentalrefrigerator.com](http://www.continentalrefrigerator.com)

Due to our continued efforts in developing innovative products, specifications subject to change without notice.

