

DESIGNER LINE UNDERCOUNTER REFRIGERATOR

Model: D32N-U

Natural Refrigerant R-290 Model

Designer Line

32" Undercounter Refrigerator with Solid Door



ENERGY STAR® Qualified Commercial Refrigerator

Stainless steel front, top, end panels and interior, aluminum back.



Options and Accessories

(upcharge and lead times may apply)

Stainless steel back	Door lock
Additional epoxy coated steel shelves	Special electrical requirements (consult factory)
Stainless steel shelves	

Consult factory for other model configurations, options and accessories.

Project Name:

Model Specified:

Location:

Item No:

Quantity:

AIA #:

SIS #:

Standard Model Features

REFRIGERATION SYSTEM

- Performance rated refrigeration system
- Natural, environmentally safe, high efficiency R-290 refrigerant¹
- Automatic, hot gas condensate evaporator
- Non-corrosive, plasticized fin evaporator coil
- Easily serviceable, back mounted compressor

CABINET ARCHITECTURE

- 2" non-CFC polyurethane foam insulation
- Smooth, polished chrome door handle
- Spring loaded, self closing door
- Magnetic snap in Santoprene™ door gasket
- Heavy duty, epoxy coated steel shelf
- Completely enclosed, vented and removable case back
- 1 3/8" diameter plate casters (factory installed)

MODEL FEATURES

- Field rehingeable door
- Off-cycle defrost
- Electronic controller with digital display & hi/low alarm
- 2" high, bottom mounted front breather air divider

¹ R-290 refrigerant meets all federal and state regulatory requirements.

Continental
Refrigerator

Toll-Free: 800-523-7138
Phone: 215-244-1400
Fax: 215-244-9579

539 Dunksferry Road
Bensalem, PA 19020
www.continentalrefrigerator.com

APPROVAL:

Model Specifications

DIMENSIONAL DATA

Net Capacity (cubic feet)	9.0 (253 cu l)
Width, Overall (inches)	32 (813 mm)
Depth, Overall (inches) (including handle & bumpers)	32 $\frac{3}{16}$ (818 mm)
Height, Overall (inches) (including 1 $\frac{3}{8}$ " plate casters)	31 $\frac{13}{16}$ (808 mm)
Shelf Area (square feet)	3.9 (0.4 sq m)
Number of Shelves	1
Number of Doors	1
Interior Depth (inches)	See Drawing
Interior Height (inches)	26 $\frac{1}{4}$ (667 mm)
Interior Width (inches)	28 (711 mm)

REFRIGERANT DATA

Condensing Unit Size (H.P.)	$\frac{1}{5}$
Capacity (BTU per hour)*	1625

ELECTRICAL DATA

Voltage (International)	115/60/1 (220/50/1)
Total Amps (International)	2.5 (2.2)
10 ft. Cord/Plug [attached] (International)	Yes (No)

SHIPPING DATA

Weight (pounds)	240 (109 kg)
Height - Crated (inches)	43 $\frac{1}{4}$ (1099 mm)
Width - Crated (inches)	40 (1016 mm)
Depth - Crated (inches)	37 $\frac{1}{4}$ (946 mm)

* Rating @ +25°F evaporator, 90°F ambient
Figures in parentheses reflect metric equivalents rounded to the nearest whole unit.



Equipped with one NEMA-5-15P Plug
(varies by country)

Model Plan Views

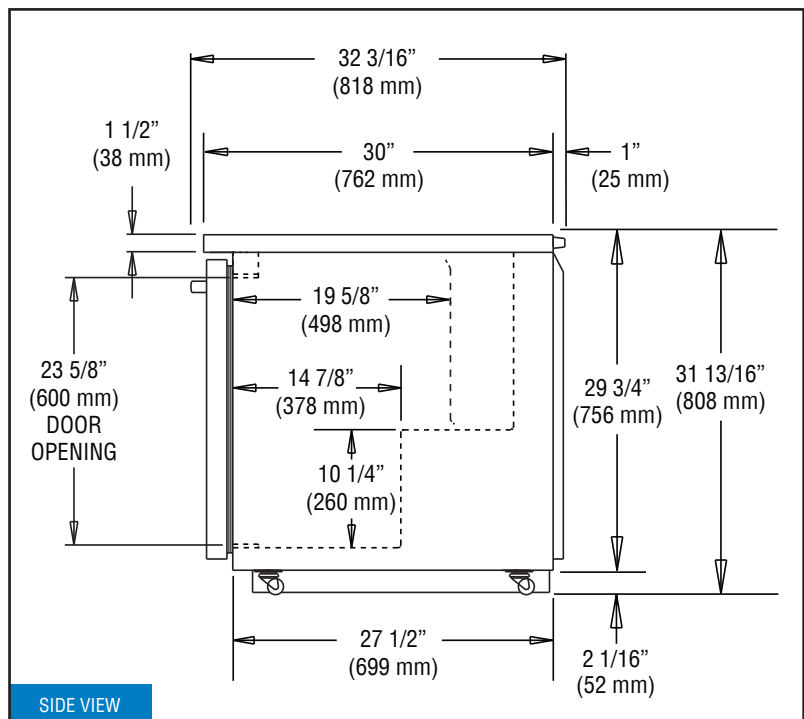
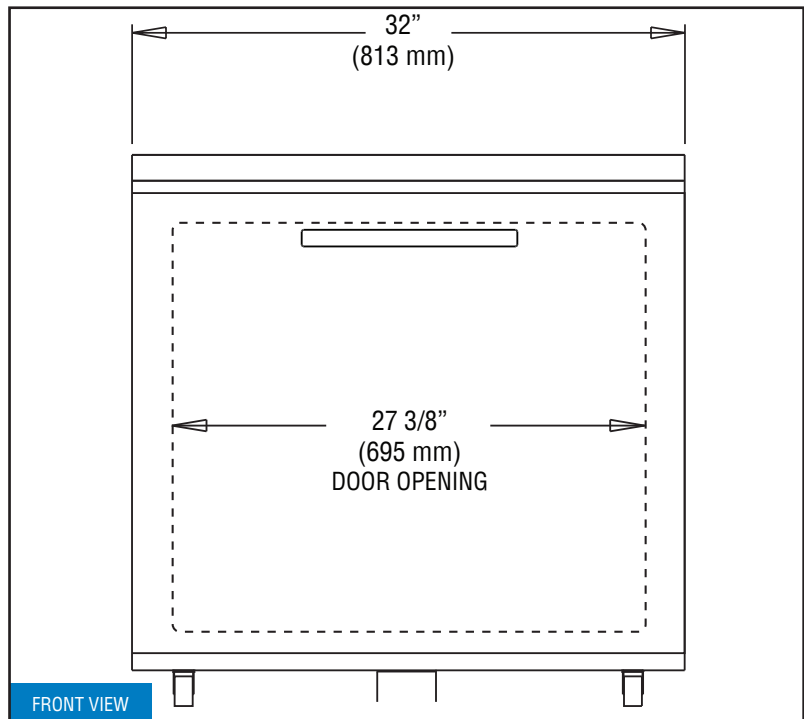

NOTE: For proper operation, the area under and in front of the cabinet **must** not be obstructed in any way.

Continental
Refrigerator

Toll-Free: 800-523-7138
Phone: 215-244-1400
Fax: 215-244-9579

539 Dunksferry Road
Bensalem, PA 19020
www.continentalrefrigerator.com

Due to our continued efforts in developing innovative products, specifications subject to change without notice.

