



Project \_\_\_\_\_

AIA # \_\_\_\_\_ SIS # \_\_\_\_\_

Item # \_\_\_\_\_ Quantity \_\_\_\_\_ C.S.I. Section 114000

## TE Series

Refrigerated Equipment Stands  
Self-Contained  
Six Drawer Models

### STANDARD PRODUCT FEATURES

- Stainless Steel Exterior & Interior
- Stainless Steel Top w/Drip Guard (Marine) Edge
- Reliable Microprocessor Control With LED Temperature Display
- Balanced, Self-Contained Refrigeration System Using R-450A
- Front-Breathing Design for "Zero-Clearance" Installation
- Non-Electric Automatic Condensate Evaporator
- Condenser Filter (protects coil)
- Off-Cycle Evaporator Defrost
- Controllable Anti-Condensate Drawer Perimeter Heaters
- Full Length Drawer Handle with Gasket Guard
- Magnetic Snap-In Drawer Gaskets
- Easily Removable Drawers Accomodate 12" x 20" x 6" Pans (pans by others)
- Self-Closing Drawers with Stay-Open Feature
- Heavy Gauge Stainless Steel Drawer Slides
- Side, Front & Rear Access Panel for Ease of Service & Maintenance
- NEMA 5-15P Plug with 9' Cord & Cord Retainer
- Set of Eight (8) 4" Casters on Adjustable Caster System
- Three (3) Year Parts and Labor Warranty
- Five (5) Year Compressor Parts Warranty



This unit is listed by Underwriters Laboratories Inc., to U.S. and Canadian safety standards and Listed by NSF International. Consult the factory or units data plate for approval information.

### ACCESSORIES & OPTIONS

- Set of 6" High Stainless Steel Legs in Lieu of Casters
- 6" Cabinet Length Extension
- Stainless Steel Exterior Finished Back
- Export 220/50/1 Voltage
- System Relocated to Right Side

### AVAILABLE CONFIGURATIONS

Two, Four & Six Drawer Models, 34" Deep

**Model**

TE096HT  
TE110HT

**Model Type**

96" 6-Drawer Model  
110" 6-Drawer Model

Approved by \_\_\_\_\_ Date \_\_\_\_\_ Approved by \_\_\_\_\_ Date \_\_\_\_\_

### MODELS

Six Drawer Models: TE096HT, TE110HT

CLICK  
**TRANSFER**   
For KCL CADalog Website

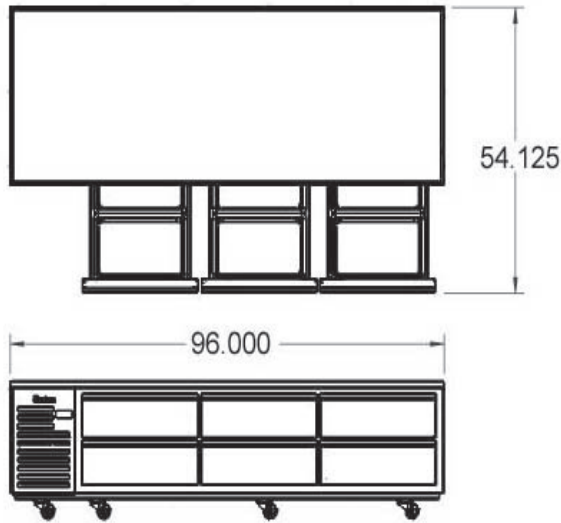

Elevation - TE096HT

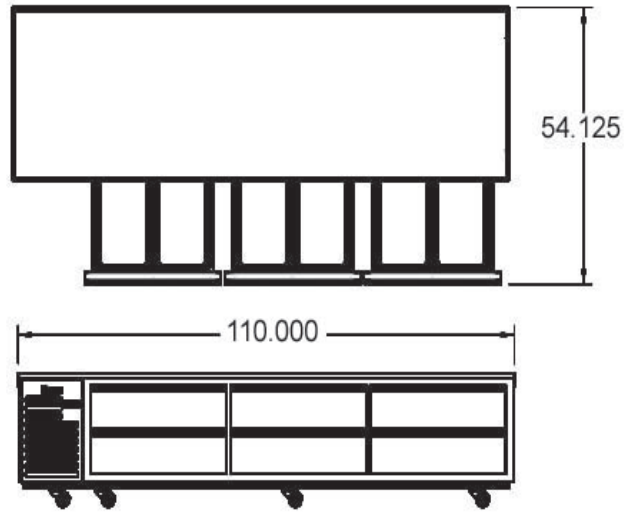

Elevation - TE110HT

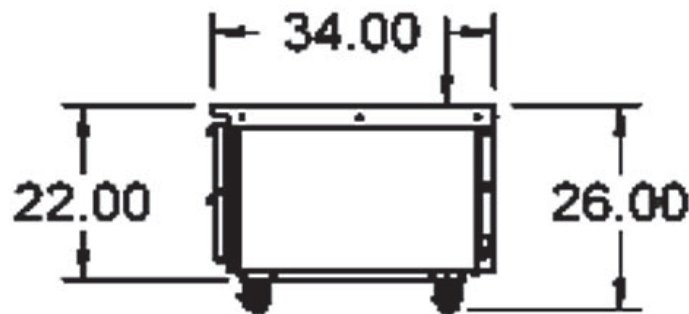

Section - All  
Models



**MODELS**

**TE096HT, TE110HT**

MODELS	TE096HT	TE110HT
<b>CABINET DIMENSIONAL DATA</b>		
Length - Overall in.	96 (243.8 cm)	110 (279.4 cm)
Depth - Cabinet Only in.	32 (81.3 cm)	32 (81.3 cm)
Depth - Door Open in.	54 1/8 (137.5 cm)	54 1/8 (137.5 cm)
Depth - Over Handle in.	34 1/8 (86.7 cm)	34 1/8 (86.7 cm)
Height - Overall on 4" Casters <sup>1</sup> in.	26 (66 cm)	26 (66 cm)
Max Top Load Capacity lbs.	1500 (680.4 kg)	1500 (680.4 kg)
Pan Capacity - 12" x 20" x 6"	12	12
Pan Orientation	Front to Back	Side by Side
Drawers Per Cabinet	6	6
<b>ELECTRICAL DATA</b>		
Voltage	115/60/1	115/60/1
Plug	NEMA 5-15P	NEMA 5-15P
Full Load Amperes	8.5	8.5
MDEC <sup>2</sup>	N/A	N/A
<b>REFRIGERATION DATA</b>		
Refrigerant	R-450A	R-450A
Refrigerant Amount oz.	21 (595.3 gr)	21 (595.3 gr)
BTU/HR   HP <sup>3</sup>	3500   1/2 HP	3500   1/2 HP
<b>SHIPPING DATA</b>		
Length - Crated in.	108 (274.3 cm)	151 (383.5 cm)
Width - Crated in.	42 (106.7 cm)	42 (106.7 cm)
Height - Crated in.	35 (88.9 cm)	35 (88.9 cm)
Volume - Crated cu. ft.	92 (2605.2)	129 (3652.9)
Weight - Crated lbs.	760 (345 kg)	845 (383 kg)

**NOTES:**

1. Height as measured without optional stainless steel work top.
2. MDEC= Maximum Daily Energy Consumption
3. Based on a 90°F ambient and 20°F evaporator. For information on remote models, please refer to form TR35837.

When ordering please specify: Voltage, Hinging, Options and any additional warranties.

Equipped with one NEMA 5-15P Plug 

**EQUIPMENT SPECIFICATIONS**

**CONSTRUCTION, HARDWARE, INSULATION**

Cabinet exterior front, sides, louver assembly and drawers are constructed of heavy gauge stainless steel, exterior back and bottom are constructed of heavy gauge galvanized steel. Cabinet interior sides, top and bottom are constructed of heavy gauge stainless steel. A set of 4" high casters are included standard. Both the cabinet and drawers are insulated with an average of 2" thick high density, non-CFC foamed in place polyurethane.

**SELF-CONTAINED REFRIGERATION SYSTEM**

The left side mounted, self-contained, balanced refrigeration system using environmentally friendly, non-flammable R-450A refrigerant features an off-cycle defrost, capillary tube, air-cooled hermetic compressor, automatic condensate evaporator, and a dedicated rear-mounted evaporator design which distributes cold air through each drawer section. A 9' cord and retainer is provided. Standard operating temperature is 34° to 38°F (1.1° to 3.3°C).

**CONTROL**

The easy to use water resistant microprocessor control is supplied standard. It includes a 3-Digit LED Display, and a Fahrenheit or Celsius Temperature Scale Display Capability.

**DRAWERS**

Each heavy-duty drawer is designed to accommodate 12" x 20" x 6" deep pans. They are constructed using heavy gauge stainless steel drawer slides and 2" diameter stainless steel rollers. Drawers include both a self-closing and stay-open feature.

**WARRANTY**

Both a three year parts and labor warranty and a five year compressor warranty (self-contained models only) are provided standard.

CONTINUED PRODUCT DEVELOPMENT MAY NECESSITATE SPECIFICATION CHANGES WITHOUT NOTICE.