

MOTAK

24" Full Cube Undercounter Ice Machine Model #: KT-UIF-200



Product Details

- Stainless steel, black trim exterior
- Air-cooled compressor
- Programmable, user-friendly digital controls
- Digital screen displays ice machine status
- Antimicrobial agent within polyethylene storage bin liner for improved sanitation
- Automatic cleaning cycle and bin overflow prevention
- Internal blue LED light
- 6" adjustable leveling legs
- Includes ice scoop with internal scoop holder

Not suitable for installation in non-commercial or residential applications.

Certifications



Plan View

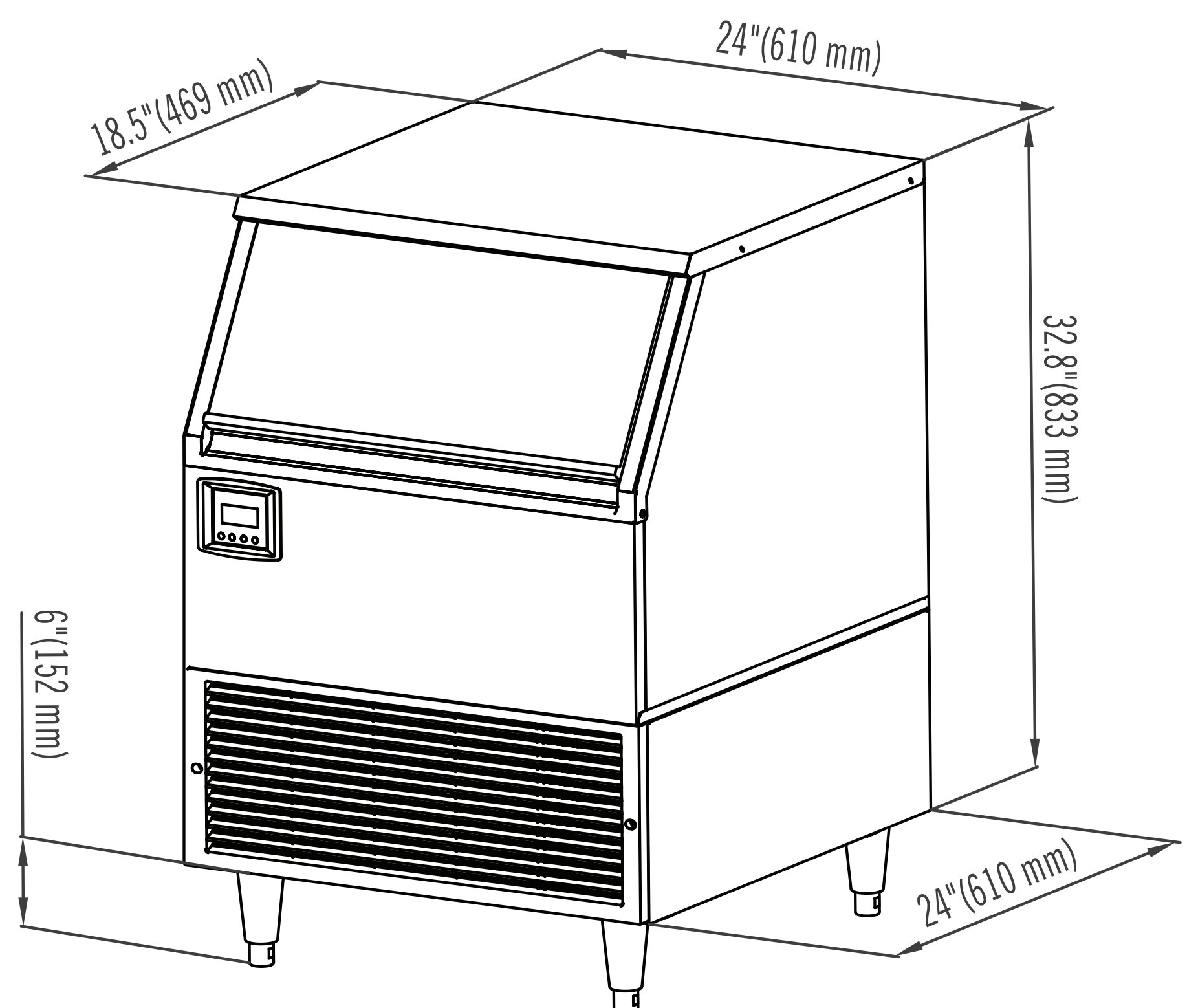

Specifications

Model	EXTERNAL DIMENSIONS	DAILY ICE PRODUCTION (70°F AIR / 50°F WATER)	ICE BIN STORAGE CAPACITY	NET WEIGHT / SHIPPING WEIGHT	AMP DRAW (MAKING / HARVESTING)	REFRIGERANT AND CHARGE SIZE	ELECTRICAL
KT-UIF-200	24" X 24" X 39" (610 X 610 X 986 MM)	199 LBS (90 KG)	75 LBS (34KG)	141 LBS (64 KG) 157 LBS (71.5 KG)	7A / 7.4A	R-404A 8.11OZ (230G)	115V / 60HZ / 1PH

MOTAK reserves the right to make changes to the design or specifications without prior notice.

JUL1223