

N°32350 C

03/2009

# Cutter-émulsionneur 4,5 L. 5,5 L. et 7 L.

## Food processor Emulsifier Trituradora-emulsionadora



Manuel d'utilisation

FR

User manual

US

Manual de utilización

ES

**1.1**

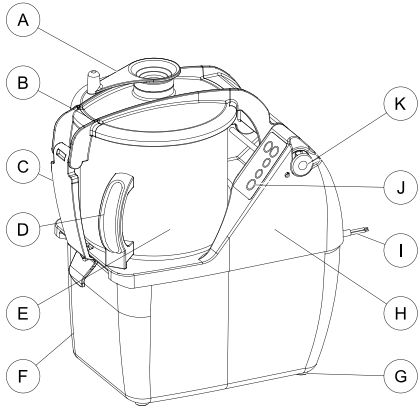

K45 31-03/2006

**2.1**

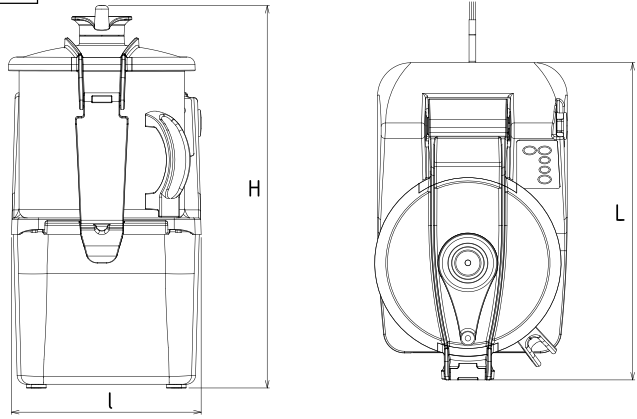

K45 31-03/2006

**2.3a**

A	B (V)	C (HZ)	D(W)	E(A)	F(A)
3	380/440	50/60	650 900	1.8 2.1	10
3	380/440	50/60	750 1000	2.1 2.3	10
3	380/440	50/60	900 1200	2.5 2.8	10
1	200/240	50/60	1000	5	16
1	200/240	50/60	1300	6	16
1	200/240	50/60	1500	6.9	16

K45 31-06/2008

	K45	K55	K70
A	25	26	27
B	22	23	24
C	580 x 300 x 600		
D	415 x 256 x 470		422x256x510
E	564 x 256 x 685		600x256x691

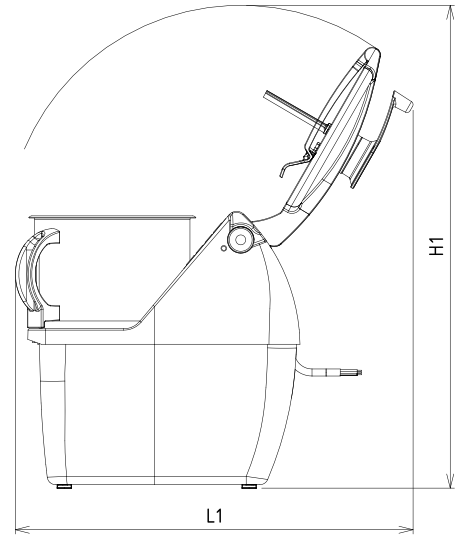

**3.1**

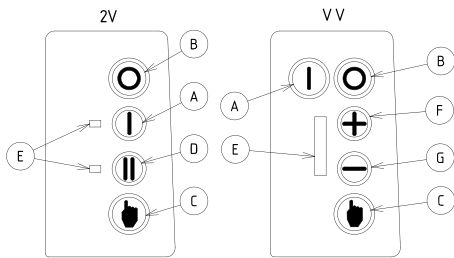

K45 31-06/2008

**3.2**

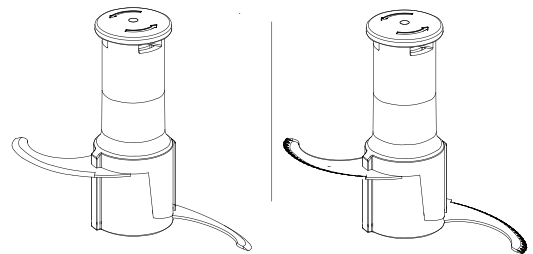

K45 31-03/2006

**3.3**

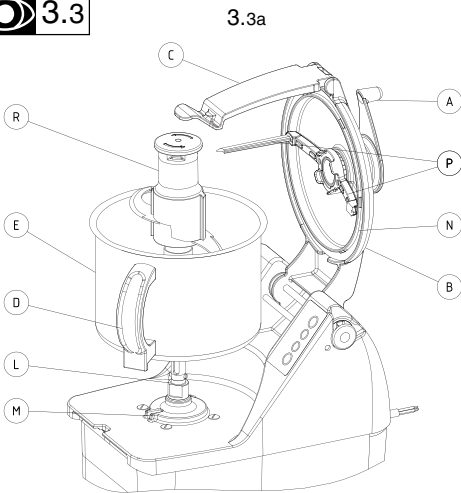

K45 31-03/2006

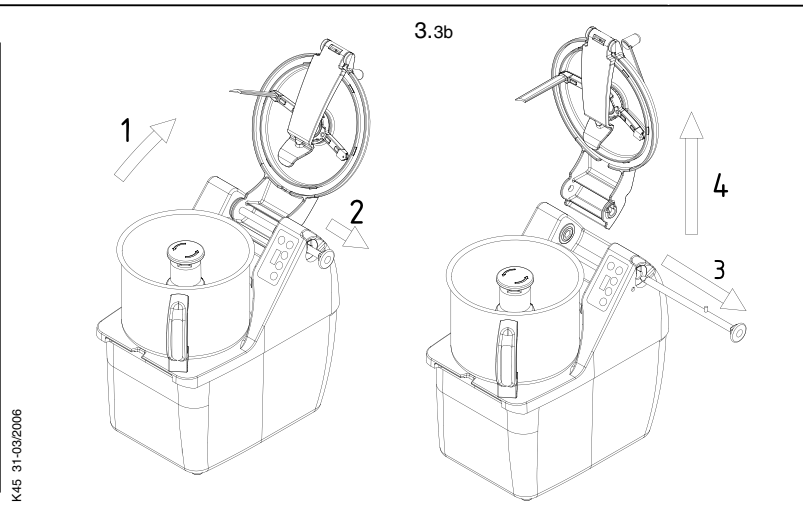

K45 31-03/2006

 3.3

3.3c

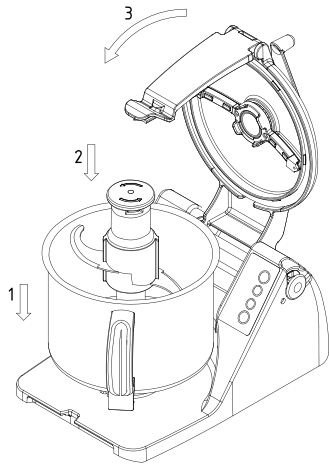

K45 31-03/2006

 3.4

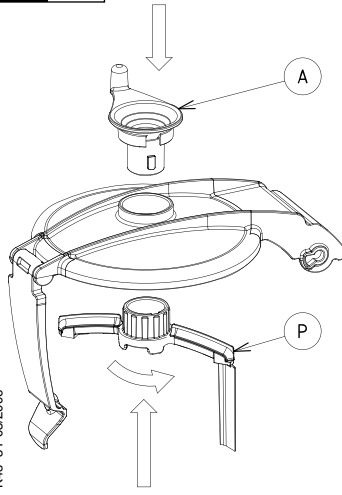

K45 31-03/2006



## Contents

Introduction	1	Maintenance	4
Installation	1	Compliance with regulations	5
Use and safety	2	Parts list - exploded view	A
Cleaning and hygiene	4	Electrical diagrams	M
Fault-finding	4		

## Introduction

The User Manual contains useful information for the user on how to work correctly and in complete safety, and is designed to make it easier to use the machine (called "machine" or "appliance" below).

What follows is in no case intended to be a long list of warnings and constraints, but rather as a series of instructions meant to improve the service provided by the machine in every respect, and particularly to avoid a series of injuries or damage to equipment that might result from inappropriate procedures for use and management.

It is essential that all the people responsible for transporting, installing, commissioning, using, maintaining, repairing or dismantling the machine should consult this manual and read it carefully before proceeding with the various operations, in order to avoid any incorrect or inappropriate handling that might be result in damage to the machine or put people's safety at risk.

It is just as important that the Manual should always be available to the operator and it should be kept carefully where the machine is used ready for easy and immediate consultation in case of any doubt, or in any case, whenever the need arises.

If after reading the Manual, there are still any doubts concerning how to use the machine, please do not hesitate to contact the Manufacturer or approved After Sales Service provider, who is constantly available to ensure quick and careful service for improved machine operation and optimum efficiency.

Note that the safety, hygiene and environmental protection standards currently applicable in the country where the machine is installed must always be applied during all phases of machine operation. Consequently it is the user's responsibility to ensure that the machine is operated and used solely under the optimum safety conditions laid down for people, animals and property.

## Introduction

### 1.1 DESCRIPTION

- This professional food processor / emulsifier can be used in the preparation of minces, blends and emulsions, in particular in a hospital environment, in gourmet catering and in dietetics. It can also be used as a food processor / mixer by removing the scraper for grinding or kneading the hardest of products.
- For special preparations which do not come under the scope of food: (PLEASE CONTACT US)



A Removable bowl-lid scraper handle with centre pourer hole

- B Removable transparent lid with centre pourer hole
- C Lid locking handle
- D Bowl handle
- E Bowl (capacity 4.5, 5.5 or 7 litres depending on model)
- F Casing
- G Non-slip pads
- H Body
- I Power supply lead
- J Control panel
- K Locking pin

## Installation



### ATTENTION!!

Machine storage: -25°C to +50°C

Ambient temperature during operation: +4°C to +40°C

This machine is for professional use and must be used by staff trained to use, clean and maintain it, in terms of reliability and safety.

Use the machine in adequately lit premises (See applicable technical standard for the country of use. In Europe, refer to standard EN 12464-1)

When handling the machine, always check that the parts taken hold of are not mobile elements: risk of dropping and injury to the lower limbs.

The machine is not designed for use in explosive atmospheres.

### 2.1 DIMENSIONS - WEIGHT (INDICATION ONLY)

A Gross packaged weight (Kg)

B Net weight (Kg)

C Packaging dimensions (mm): L x W x H

D Machine dimensions: L x W x H (mm)

E Space required for opening and removal: L1 x W x H1 (mm)

### 2.2 POSITION

- Stand the appliance on a working surface (table, base, etc.) of a height of between 700 and 900 mm. Its 4 pads provide it

with perfect stability.

- It does not need to be fixed and can easily be moved.

## 2.3 ELECTRICAL CONNECTION



### ATTENTION!!

Connection to the electrical power supply must be done according to proper professional practice by a qualified and authorised person (see current standards and legislation in the country of installation).

If an adapter is used on the socket, a check must be made that the electrical characteristics of this adapter are not lower than those of the machine.

Do not use multiple plugs

The AC power supply to the machine must comply with the following conditions;

- Maximum voltage variation:  $\pm 5\%$
- Maximum frequency variation:  $\pm 1\%$  on a continuous basis,  $\pm 2\%$  over short periods

**ATTENTION: the electrical installation must comply (for design, creation and maintenance) with the legal and standard requirements in the country where used.**

- Check that the electric mains voltage, the value shown on the specification plate and the label on the power cable are the same.
- The machine's electrical power supply must be protected against voltage surges (short-circuits and excess voltages) by using fuses or thermal relays of the appropriate gauge relative to the place of installation and machine specifications – see the specifications shown in column G of figure 2.3a

**ATTENTION: Concerning protection against indirect contact (depending on the type of power supply provided and connection of the exposed conductive parts to the equipotential protection circuit), refer to point 6.3.3 of EN 60204-1 (IEC 60204-1) with the use of protection devices for automatic shut-off of power in the event of an insulation fault with a TN or TT, system, or for the IT system, with the use of a permanent insulation or differentials controller for automatic shut-off. The requirements of IEC 60364-4-41, 413.1 must apply for this protection.**

**For example: in a TT system, a differential circuit breaker must be installed upline of the power supply, with a suitable power cut-off (e.g.: 30 mA) on the earthing installation for the place where it is planned to install the machine.**

**ATTENTION: Failure to comply with these instructions means the customer runs the risk of machine failure and/or accidents due to direct or indirect contacts.**

- This food processor is available in three versions:
  - Single speed : Single phase - one voltage only.
  - Two-speed : Three-phase - one voltage only.
  - Variable speed : Single phase - one voltage only.
- Check that the electric mains voltage and the value shown on the specification plate and the power cable label are the same.

- The machine must be protected by a residual current device (RCD) and one fuse per phase, of a rating shown in column F of the specifications.

• **Motor specifications:**  2.3

- A** Number of phases (1 = single phase or 3 = three-phase)
- B** Nominal voltage in volts
- C** Frequency (Hertz)
- D** Nominal rating (Watts)
- E** Nominal current (Amperes)
- F** Rating of the fuse protecting the electric line (Amperes)

**Single phase, one voltage, one speed only**

- A single phase 2-pole + earth wall socket rated at 16 A will be required.

**Three-phase, one tension, two speeds**

- A standard 3-phase + Earth wall socket rated at 20A will be required and an appropriate sealed plug to be fitted onto the power lead.

 Must be earthed by green/yellow wire.

- Check the direction of rotor rotation at both speeds:
  - Press the On button (see § 3.1).
- Make a visual check through the lid that the rotor turns in an anti-clockwise direction () at both speeds (see arrow etched on the rotor handle).
- If the direction of rotation is reversed, change over the 2 phase wires on the power socket.

**Single phase, one voltage, variable speed**

- The food processor is powered by single phase current up to the variable speed unit which transforms the current to power the three-phase motor.
- An easily accessible, standard 2-pole + earth sealed wall socket rated at 16 A will be required.

- Warning to the installer:  
This electronic variable speed food processor is fitted with an integral filter which does not pass through the variable speed unit. To be effective, the machine's earth must be of good quality, otherwise interference may pass through via the variable speed unit and damage it.

 Must be earthed by green/yellow wire.

- **No earth connection = no protection = risk of failure + DANGER for the user!**

*Note: The earth values are defined according to the residual differential current (See standard NFC 15100 and PROMOTELEC guide) and must be checked by an electrician.*

 Damage caused by a lack of earth will not be covered by the warranty

 In certain cases, depending on the sensitivity of the protective RCD, SI-type (Super Immunity) devices may need to be fitted to prevent unwanted tripping.

To PAT test the Electrolux Range of Food Preparation Equipment, the PCB board needs to be disconnected before any test is done. This is due to the fact that the boards are fitted with a grounding diode that can give incorrect result during such a test. Also on a standard appliance a flash test of 25 amps and up to 3000v is used but, as you would expect, to use this on equipment, which has a printed circuit, board would be quite destructive to that board. We would recommend the use of a PAT tester approved for computer systems which use a lower rate of amps.

The appliance is perfectly safe and is CE certificated. There are two ways to get overcome this problem.

- Disconnect the board as instructed and test using test for PC's,
- Or install the mixer on a fused spur (no plug) as this takes it away from being a portable appliance and the PAT test is then not needed.



## ATTENTION!!

Clean the machine properly prior to its first use

Uncontrolled closure of the lid or ram press involves a risk of crushing the fingers.



Never put a hand in the ejection area while the machine is in operation; risk of injury. It is strictly forbidden to put the safety systems out of action or modify them: Risk of permanent injury!!!!

Check that the safety devices operate correctly each time before using (see paragraph on «safety system adjustments»). Never put a hand, a hard or frozen object in the appliance

For health and safety reasons, always use a washable or disposable strong head covering that covers the hair completely.

**ATTENTION: All operations, whether using, cleaning or maintenance, present risks of cuts; never force and always keep hands a reasonable distance from cutting edges.**

**Always use appropriate protective equipment when carrying out these operations.**



### 3.1 OPERATION - SAFETY

#### • The user's safety is assured by:

- The motor stopping on releasing the lid.
- The need to have the bowl in position before it will start
- The need to press on the On button after each stoppage ("voltage loss" device).
- The braked stoppage of the motor before accessing the rotor.
- Operation by sustained pressure to check the progress of work.
- The automatic locking of the rotating rotor through its bayonet system.
- The dimension of the centre pourer hole providing the means for the addition of products in OPERATION.
- The design of the bowl (no-leak shaft).
- The easy removal of the bowl, the lid and its seal, the rotor and the scraper for cleaning them.

#### • Control panel 3.1

##### 1-speed model

- A** ON button.
- B** OFF button.
- C** ON button by sustained pressure.

##### 2-speed model

- A** ON button at low speed.
- B** OFF button.
- C** ON button by sustained pressure at low speed.
- D** ON button high speed.
- E** Display of the speed selected

#### Variable speed model

- A** ON button at the selected speed.
- B** OFF button.
- C** ON button by sustained pressure at the selected speed.
- E** Display of the selected speed
- F** To increase the speed
- G** To decrease the speed

#### • The food processor can be started up if:

- The bowl is properly in place
- The locking pin is correctly engaged (see § 3.3)
- The lid is correctly locked.

#### a) Continual operation:

Press button **A** or **D**.

For the variable-speed model, the speed can be increased or reduced while running or when at a stop by using the buttons **F** or **G**.

#### b) Operation by sustained pressure:

Press button **C** and hold down. This provides the means for controlling the progress of fine work.

#### c) Stop

Press button **B**

*Note:*

*Do not stop the food processor by releasing the lid.*

### 3.2 CHOICE OF EQUIPMENT



3.2

- The food processor / emulsifier is fitted as standard with a bowl-lid scraper and a very hard stainless steel dual-knife rotor (smooth knives for the single speed models and micro-toothed knives for the 2-speed and variable speed models).

*Note: Optional rotors suitable for other work (see table §3.5). PLEASE CONTACT US.*

- Usage as a food processor / mixer is possible by removing the scraper from the existing lid or by using a second lid with no scraper for the following types of work:

- Minced meat, vegetables, etc.
- Grinding and reduction to powder.
- Kneading dough.

### 3.3 STARTING UP



3.3A

- Before starting any work, always check the cleanliness of the rotor **R**, the bowl **E**, the lid **B** and its seal **N**, the scraper **P** and its handle **A** and the drive shaft **L**.
- To remove the lid:  **3.3B**
  - Release the lid using the handle **C**.
  - Open the lid as far as the rear stop
  - Withdraw the locking pin
  - Withdraw the lid
- Use the notch at the back of the lid to withdraw the seal **N**.
- For re-assembly, proceed in the reverse order, making sure that the locking pin is fully pushed in when the lid is in the fully open position.

- Raise the bowl **E** vertically by its handle **D**. The rotor **R** is released automatically. The rotor can also be removed separately.
  - To fit the scraper onto the lid see §3.4.
  - To equip the food processor, install:  **3.3C**
    - The bowl **E** on the centre axis, making sure the bowl locking stud is properly positioned in its housing **M**.
    - The rotor **R** on the drive shaft **L** as far as the stop. Next introduce the products to be worked (never before installing the rotor).
    - Pull down the lid **B** (fitted with its seal **N**) onto the bowl **E** and lock it with the handle **C**.
- The appliance is ready for use.

### 3.4 USING



3.4

#### • Fitting the scraper onto the lid:

- Fit the scraper **P** underneath in the lid centre hole.
- Position the handle **A** lug in the scraper housing and lower it to the stop.
- Hold the scraper hub with one hand and, while exerting pressure between the 2 parts, turn the handle clockwise (↻) (seen from above) to lock them.

- Always start at slow speed before changing to a faster speed.
- Use the speed under sustained pressure to start or finish work requiring a certain amount of surveillance or a precise degree of finishing.
- While working, turn the handle clockwise (↻) (seen from above) to clean the bowl and lid walls and to give consistency to the product. To loosen doughy products from the scraper, turn the handle sharply clockwise (↻) and then anti-clockwise (↺).

#### • To remove the scraper:

- Hold the scraper hub with one hand and, while exerting pressure between the 2 parts, turn the handle anti-clockwise (↺) (seen from above) to release them.

Note:

*The lid centre hole can be closed off with the stopper supplied with the machine when the scraper is not being used.*

Note:

- *Liquid products or ingredients may be introduced by the handle chute.*
- *The slope in the knives ensures a fast, consistent mix.*



Never introduce the hand or hard bodies into the bowl when the machine is on.

### 3.5 SOME EXAMPLES OF USE (THE QUANTITIES ARE GIVEN AS AN INDICATION ONLY)



Do not work hard products (whole vegetables, chunks of meat, etc.) with the scraper - risk of damaging it.

	Qty	Type of knife	Quantity by weight of finished product								
			K45 1-Sp	K45 2-Sp	K45 V-Sp	K55 1-Sp	K55 2-Sp	K55 V-Sp	K70 1-Sp	K70 2-Sp	K70V-Sp
Sausage meat	min.	Smooth	100 g			100 g			200 g		
	max.	Smooth	1,5 kg			2 kg			2,5 kg		
Minced steak / steak tartare	min.	Smooth	100 g			100 g			200 g		
	max.	Smooth	1,5 kg			2 kg			2,5 kg		
Onion	min.	Smooth	150 g			150 g			150 g		
	max.	Smooth	1 kg	1,5 kg		1,3 kg à 1,5 kg	2 kg		2 kg	2,5 kg	
Parsley	min.	Smooth	1 bunch (approx. 100 g)			1 bunch (approx. 100 g)			1 bunch (approx. 100 g)		
	max.	Smooth	3 bunches (approx. 300 g)			4 bunches (approx. 400 g)			5 bunches (approx. 500 g)		
Mayonnaise	min.	Either	100 g			100 g			100 g		
	max.	Either	2 kg			2,5 kg			3,5 kg		
Carrot emulsion	min.	Micro-toothed		600 g		600 g		1 kg			
	max.	Micro-toothed		1 kg		1,5 kg		2,5 kg			
Garlic and parsley	min.	Smooth	200 g			300 g			300 g		
	max.	Smooth	1 kg	1,5 kg		1,2 kg	1,8 kg		1,8 kg	2,5 kg	
Shortcrust pastry	min.	Micro-toothed	350 g	160 g		350 g	160 g		350 g	160 g	
	max.	Micro-toothed	1,3 kg			1,7 kg			2,5 kg		
Dough (60 % flour)	min.	Either	160 g			160 g			160 g		
	max.	Either	2 kg			2,4 kg			3 kg		
Almonds or Hazel	min.	Micro-toothed	100 g			100 g			200 g		
	max.	Micro-toothed	1 kg			1,5 kg			2 kg		
Parmesan	min.	Smooth	100 g			100 g			200 g		
	max.	Smooth	750 g			1 kg			1,5 kg		

## Cleaning and Hygiene



### ATTENTION!!

Before dismantling any part, disconnect the appliance from the power supply.

Before using any cleaning product, be sure to read the instruction and safety instructions accompanying the product and use appropriate protective equipment.

Do not clean the machine with a pressure cleaner

Take care when handling the rotor, screens and plates. (Risk of CUTS – ELECTRIC SHOCK).



#### 4.1 BETWEEN TWO DIFFERENT SESSIONS

- Remove the bowl, the lid and its seal, the scraper and the rotor (see § 3.3 and 3.4).
- Clean the above items under a tap or in a basin with hot water with the addition of detergent/disinfectant product or a degreasing product (if working fatty products).
- Check the various items have been cleaned properly.

Note:

- Use cleaning products which are compatible with the plastic (polycarbonate) and stainless steel parts.
- Do not use abrasive products for cleaning the transparent lid.



Handle the rotor with care. (Risk of CUTS - SHOCKS).

#### 4.2 AFTER USING

- Unplug the machine.
- For bowl, lid, scraper and rotor removal and cleaning, see § 3.3 and 3.4.
- Where necessary, clean the outside of the machine with a damp sponge with the addition of a detergent/disinfectant product, paying particular attention to the rotor drive shaft, the bowl support zone and the bowl positioning stud housing and then rinse.

Note:

- Use cleaning products which are compatible with the machine component materials.
- The drive shaft and the inside of the rotor must be kept absolutely clean.

- The bowl, the lid, the scraper and the rotor may be put in a dishwasher with the knives protected against impacts.



Do not clean the machine with a pressure cleaner.

- To prevent acid stains on the rotor knives, it is recommended that they are carefully dried before storage and the rotor is put in a cold room in order to limit the development of microbes.
- After cleaning the lid, do not lock it. Leaving the air to circulate prevents condensation and the concentration of any residual odours.

## Fault finding

### 5.1 IF THE APPLIANCE WILL NOT START, CHECK THAT:

- The machine is plugged in properly.
- The socket is correctly supplied with electric power.
- The lid is locked properly (see § 3.3).
- The pin is pushed in properly (see § 3.3).
- If the food processor stops while in use:
  - The motor temperature sensor has tripped. Wait a few minutes before restarting.
  - Reduce the volume of product.

### 5.2 ABNORMAL NOISE

- Stop the machine.
- Check:
  - The bowl, the rotor and the scraper are properly in place.
  - That there are no foreign bodies inside the bowl.
- Remove, clean where necessary and refit.
- If the noise persists and the appliance lacks power, check:
  - For three-phase motors, that the motor is not running on two phases.



If the incident persists, contact your dealer's service department.

### 5.3 WORK QUALITY

- For work which is beyond reproach, quick and with no heating up:
  - Always use properly sharpened knives which are impact-free.
  - Keep an additional rotor for use on fine work (e.g.: chopping parsley with smooth knives, kneading with serrated knives).
  - Do not work with too-large volumes of products which causes heating up (meat and dough).
- Note:
  - The micro-toothed knives have the cutting qualities of a smooth and serrated knife, which reduces sharpening them.
  - Where necessary, rework the edge of the knives on the side opposite the sharp area using a sharpening stone.

## Maintenance

### 6.1 MECHANISM



Maintenance may only be carried out by persons who are qualified, trained and authorised.

- The food processor requires only minimum maintenance (the motor and mechanism bearings are greased for life).

- It is recommended that at least once a year the following are checked:
  - Grease the seal located at the base of the drive shaft with an edible fat.
  - Check the condition of the electrical connections

### 6.2 SAFETY DEVICE ADJUSTMENT

- The correct operation of the safety devices should be checked frequently. The motor should stop by braking on opening the lid in less than 4 seconds.
- If this function is not carried out:
  - Do not use the machine.
  - Have it adjusted by your dealer's service department.

### 6.3 ELECTRICAL COMPONENTS

• **Access to the electrical components:**

- Unplug the machine and turn it over.
- Remove the casing (4 nuts – 7 mm spanner).



Residual voltage on the capacitor terminals.

• The capacitors may remain electrically charged. In order to avoid any risk, on working on the machine it is recommended that these are discharged by connecting their terminals using an insulated conductor (for example, a screwdriver).

See electrical wiring diagrams at the end of this manual.

• **Wire colour identification:**

- Power circuit: black
- Control circuit: red
- Motor: **A:** red - **B:** green - **C:** yellow - **D:** white - **E:** blue - **F:** black - **G:** orange - **H:** purple - **I:** grey - **J:** brown - **K:** pink
- Phases: **L** Single phase ; **L1 - L2 - L3** Three-phase
- Neutral: **N**
- Earth: Green/Yellow **B/C**

• **Component identification:**

- S1** : Lid safety device
- S2** : Bowl safety device
- S3** : Motor probe
- S5** : Locking pin safety device
- M** : Motor
- V** : Variable speed unit
- CC** : Control card
- CPU**: Power card
- CD** : Start capacitor
- CP** : Running capacitor
- CF** : Brake capacitor
- K1** : Start relay
- B1** : Terminal block
- Fur** : Spare fuse
- X** : Power supply cord
- DT** : Dubber of tension

### 6.4 ADDRESS FOR SERVICE REQUIREMENTS

We advise you first to contact the dealer who sold you the machine.



For any requests for information or orders for spare parts, specify the type of machine, the serial number and the electrical specifications.

The manufacturer reserves the right to modify and make improvements to its products without notice.

Dealer's stamp

Date of purchase: .....

## Compliance with regulations

**The machine has been designed and manufactured in compliance with:**

- Machine directive 2006/42 CEE.
- CEM directive 2004/108 CEE.
- Low voltage directive 2006/95/CEE,
- Machine recycling directive 2002/95/CEE
- directive "WEEE" 2002/96/CEE

The "♻️" symbol on the product indicates that this product should not be considered as household rubbish. Instead, it should be taken to a recycling area for electric and electronic equipment. By making sure that the product is correctly disposed of in this way, you are assisting in preventing damage to the environment and to the health of persons which may result following uncontrolled disposal of this product. For further information on recycling this product, please contact the sales department or the product retailer, the after-sales department or the waste treatment department in question.

- directive "Waste" 2006/12/CEE

The machine is designed in such a way that it does not contribute, or contributes as little as possible, to increasing the quantity or noxiousness of waste and the risks of pollution.

Make sure you respect the recycling conditions.

- directive "Packaging and packaging waste" 94/62/CEE

The machine packaging is designed in such a way that it does not contribute, or contributes as little as possible, to increasing the quantity or noxiousness of waste and the risks of pollution.

Make sure you eliminate the various parts of the packaging in the appropriate recycling points.

• **European standards:**

EN 12852- Food processors. Instructions relating to health and safety.

**This compliance is certified by:**

- The CE conformity mark, affixed on the machine,
- The relevant CE declaration of conformity, associated with the warranty.
- This instruction manual, which must be given to the operator.

**Acoustic specifications:**

- The acoustic pressure level measured in accordance with the test code EN ISO 3743.1-EN ISO 3744 < 70 dBA.

**Protection indices according to standard EN 60529-2000:**

- electrical controls IP55
- machine overall IP34

**Integral safety:**

- The machine has been designed and manufactured respecting the regulations and standards relating to it indicated above.
- The operator must be trained before using the machine and informed of any residual risks.

**Food hygiene:**

The machine is made from materials that conform to the following regulations and standards:

- Directive 1935/2004/CEE: materials and objects in contact with foodstuffs,
- Standards EN 601-2004: cast aluminium alloys in contact with foodstuffs.
- Directive EN 1672-2 : Prescriptions relating to hygiene

The surfaces of the food area are smooth and easy to clean. Use detergents which are approved for food hygiene, observing the instructions for their use.