



Ice & Water Dispenser

Model Number

DISP-500-IND



FEATURES

- Foot pedal activated ice dispensing and two manual water spigot stations
- Timed agitation
- Single water inlet connection
- Meets OSHA Requirements and Complies with California T8CCR-3395
- Seamless polyethylene liner with coved corners
- 48" wide cooler drip tray with removeable shelf
- 1 ½" foamed in-place polyurethane insulation
- Fully welded stainless steel auger and agitator
- 1/2 HP motor(s) with torque overload and recovery
- 110 volt, single phase, 15 amp power 50/60 hz
- Adjustable flanged feet
- Factory installed drain
- **Not to be used with softer ice such as Flake, Nugget or Chewlet Ice**



NAFEM

North American Association of
Food Equipment Manufacturers

Toll Free Phone: 1-800-346-3246

Local Phone: (303) 761-1615

E-mail: sales@kloppenberg.com

www.kloppenberg.com

APPLICATIONS

- Factory/
Manufacturing
- Mining
- Agriculture
- Sports Venue
- Golf Course
- Public Works
- Construction
Site
- Water/
Amusement
Park

Model Number

DISP-500-IND

Ice & Water Dispenser

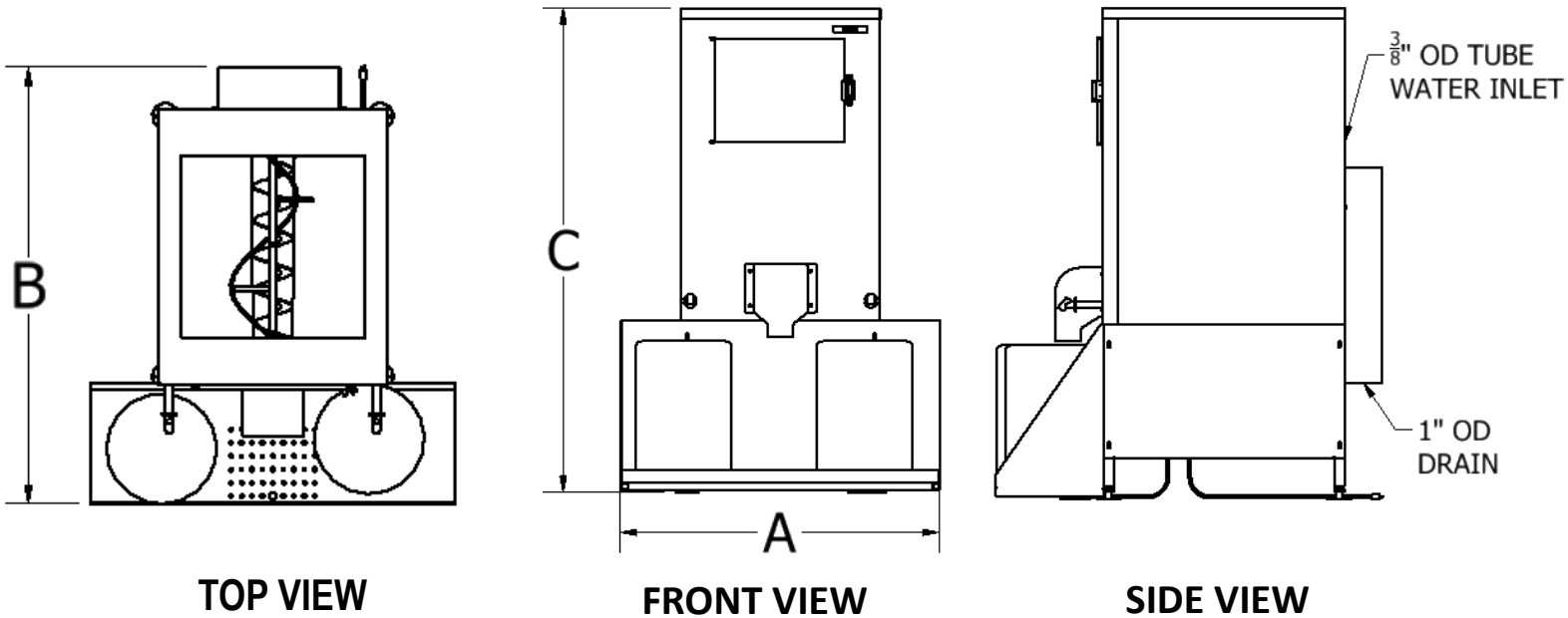

Model Number	Capacity lbs (kg)	A-Width in (mm)	B-Depth* in (mm)	C-Height in (mm)	Minimum Door Clearance in (mm)	Ship Weight lbs (kg)
DISP-500	500 (227)	48 (1,219)	59 (1,499)	72 (1,829)	48 (1,219)	585 (266)

*Depth includes 23" for the electrical components, ice chute, & shelf

OPTIONS:

- Stainless steel liner
- Fully welded stainless steel liner (coved corners)
- Power Conversion

AVAILABLE ACCESSORIES:

- Bagger Kit
- Scoops
- Totes
- Carts

Toll Free Phone: 1-800-346-3246 Local Phone: 303-761-1615

Email: sales@kloppenberg.com

Please send all PO's to purchaseorders@kloppenberg.com