



# HC2A-FS-FS/-HS-HS

Two Section Full Stainless Pass-Thru Heated Cabinet



HC2A-FS-FS/-HS-HS  
11/07/23  
Item # 13682

Item #: \_\_\_\_\_  
 Project: \_\_\_\_\_  
 Qty: \_\_\_\_\_  
 AIA#: \_\_\_\_\_

**W x D x H**  
55" x 35.75" x 79.5"\*  
\*with 4" casters

HC2A-FS-FS

HC2A-HS-HS



## Features

- ▶ Interior top-mounted heating element with fan to circulate heat through cabinet; heat shield foamed in next to heating element
- ▶ Additional storage fits 36 sheet pans
- ▶ Maximum interior storage capacity with smallest external footprint
- Stainless steel interior with stainless exterior front, sides, and top
- Energy efficient interior LED light
- Solid state digital controller with temperature alarms and LED display (Fahrenheit or Celsius)
- Cabinet and doors are insulated with 2-3/8" of CFC free, foamed in place polyurethane
- Exclusive stepped door design to protect recessed door gasket (magnetic snap-in gasket)
- Self-closing doors with stay open feature
- One piece, full length, chrome handle
- Sturdy 8 gauge stainless steel hinge plate with welded hinge pin
- Field reversible doors
- Doors locks are standard
- Stainless steel shelf supports
- (6) epoxy coated wire shelves are standard
- Standard with 4" casters (two with brakes)
- Stackable (two units high) to conserve warehouse floor space
- 10 ft. cord and plug



### Dimensions / Capacity

#### Two Section

	HC2A-FS-FS	HC2A-HS-HS
Interior Storage Capacity (CF) (AHAM)	52.4 ft <sup>3</sup>	52.1 ft <sup>3</sup>
Overall Width x Depth	55" x 35.75"	55" x 35.75"
Height (including 4" casters)	79.5"	79.5"
Door Opening Width x Height	21.75" x 59.25"	21.75" x 27.75"
Depth with Both Doors Open at 90° (front and back)	87.25"	87.25"
Adjustable Shelves	6	6
Shelf Dimensions (W x D)	21.25" x 30.75"	21.25" x 30.75"
Adjustable Center Shelves	3	3
Center Shelf Dimensions (WxD)	21.25" x 30.75"	21.25" x 30.75"
Crated Shipping Weight	625 lbs	625 lbs
Crated Length x Depth x Height	58" x 38.5" x 81"	58" x 38.5" x 81"

### Electrical / Refrigeration

#### Two Section

#### HC2A-FS-FS/HC2A-HS-HS

Voltage	208-230/60/1
HACR Breaker	20 Amps
Electrical Connection (NEMA)	L14-20P
Voltage Range	208-254
Ambient Temp. Range	45° to 100°F
Control Setpoint Range	140° to 180°F
Amperage	9 (208v) /10 (230v)
Energy Consumption (w) @ASTM F2140-11	305.40

### Options

- Additional epoxy shelves
- Stainless steel shelves
- Pan slides 1 set (2 vol. HS-3557)
- Pan slides 3 sets (6 vol. HS-5081)
- Pan slides 4 sets (8 vol. HS-3558)
- Foot pedal
- Wire slides 1 set (HS-5092)
- Wire slides 4 sets (HS-5093)
- 6" Adjustable legs
- Center Shelves 1 pack (HS-5388)
- Center Shelves 3 pack (HS-5389)



Valid in United States, Canada, Puerto Rico and U.S. Territories. Contact factory for warranty in other countries.

If GFCI is required, a GFCI breaker MUST be used in lieu of GFCI receptacle

Hoshizaki reserves the right to change specifications without notice.



# HC2A-FS-FS/-HS-HS

Two Section Full Stainless Pass-Thru Heated Cabinet



HC2A-FS-FS/-HS-HS

11/07/23

Item # 13682

## FRONT VIEW

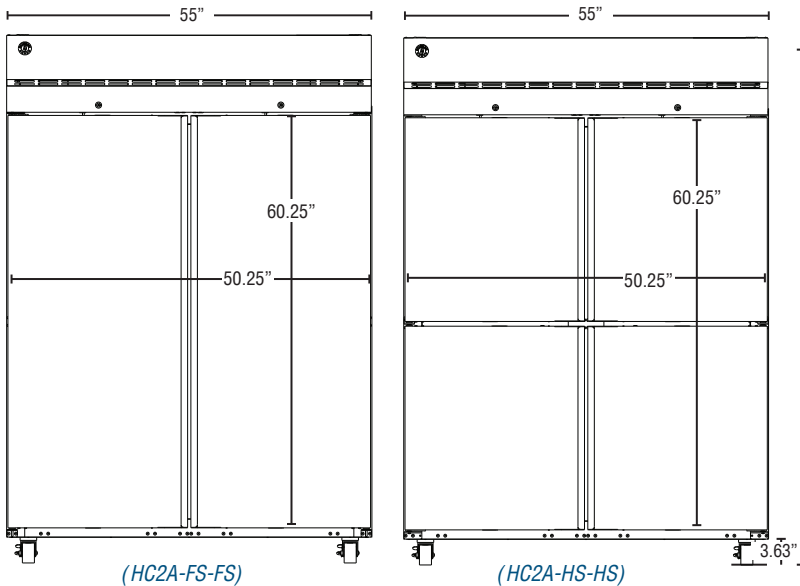

## SIDE VIEW

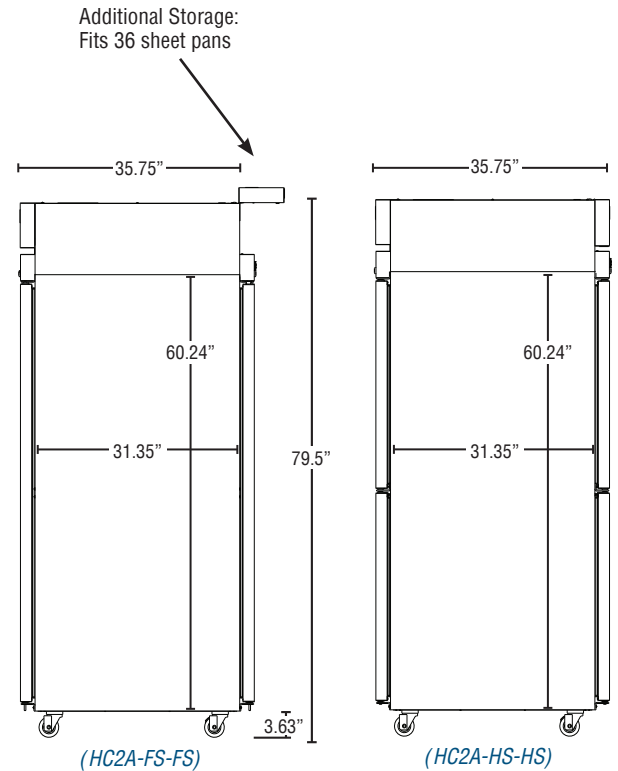

## PLAN VIEW

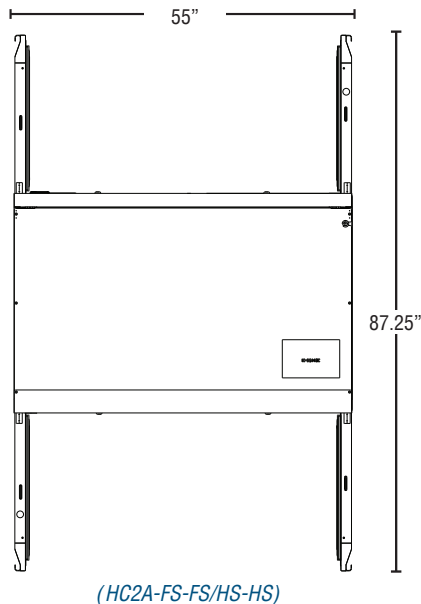

### Cabinet Construction

The exterior cabinet front, sides, and top are constructed of high quality stainless steel. The exterior back, and bottom are constructed of coated steel. The cabinet interior is constructed of stainless steel with a unique ducted air flow system. Three (3) heavy duty epoxy coated shelves per section are standard. Mounted on stainless steel pilasters shelves are adjustable in 1" increments. Cabinet walls and doors are insulated with 2-3/8" of environmentally friendly, CFC free, foamed in place polyurethane. 4" polyolefin, casters (two with brakes) are standard.

### Door Construction

Doors are constructed of a high grade stainless steel exterior and interior and are standard with locks. Hoshizaki's exclusive "stepped" design protects the recessed gasket while product is being removed from the cabinet. Doors are provided with a one piece, full length extruded aluminum flush mount handle and are mounted on eight (8) gauge stainless steel hinge plates with a welded hinge pin. Spring assisted self-closing doors are equipped with a stay open feature past 90 degrees. Snap-in magnetic door gaskets are easily removed for cleaning. Door hinging is field reversible.

### Operating System

The heating system consists of a high temperature fan which pulls air from the cabinet space and blows it across a resistive heater. From there, the air passes through a duct, which disperses the air equally across the height and depth of the cabinet through a carefully engineered louver pattern. A built-in ceramic heat shield adjacent to the heating element protects the blown foam insulation from contracting in the locally hot temperatures, maintaining the cabinet's structural integrity. A 6000 K LED lighting system illuminates the interior of the cabinet when the door is opened. Specialty high-temperature rated gaskets are recessed from the interior of the door, protecting them. Solid state digital controls monitor the operation and maintain proper temperature of the cabinet space. The controls provide visual high and low temperature and high and low voltage alarms. The LED display shows the cabinet temperature and is adjustable to Fahrenheit or Celsius. The 1-sections are 115 volts and the 2 sections are 208/230 volts.