



900RX SERIES

Heavy Duty Gas Griddles



SELL SHEET

Model 948RX



SPECIFIER STATEMENT

Low profile heavy duty gas griddle, Vulcan Model No._____. Stainless steel front, sides and front top ledge. Fully welded stainless and aluminized steel body frame. 11" low profile cooking height on 4" legs. 1" thick polished steel griddle plate with 12 gage, 4" stainless steel back and tapered side splashes. Grease chute is fully welded to stop grease migration. One 27,000 BTU/hr. "U" shaped aluminized steel burner and mechanical snap action thermostat for each 12" of griddle width. Chrome thermostat knob guards. Temperature adjusts from 200° to 550° F. One pilot safety for every two burners. Manual shut-off valve. 3½" wide stainless steel grease trough. 120V 50/60Hz 1 Amp single phase electric ignition circuit. Plug type is NEMA 5-15 USA. ¾" rear gas connection and gas pressure regulator.

Exterior Dimensions:

_____ "w x 33" d x 15½" h on 4" legs.

CSA design certified. NSF listed.

SPECIFY TYPE OF GAS WHEN ORDERING
SPECIFY ALTITUDE WHEN ABOVE 2,000 FT.

Project _____

AIA # _____ SIS # _____

Item # _____ Quantity _____ C.S.I. Section 114000

MODELS

- 924RX:** 24" w x 24" d griddle plate
- 936RX:** 36" w x 24" d griddle plate
- 948RX:** 48" w x 24" d griddle plate
- 960RX:** 60" w x 24" d griddle plate
- 972RX:** 72" w x 24" d griddle plate

STANDARD FEATURES

- Stainless steel front, sides and front top ledge with "Cool Bullnose" design
- Fully welded stainless and aluminized steel chassis frame
- 11" low profile cooking height on 4" adjustable legs
- 1" thick polished steel griddle plate with 12 gage, 4" stainless steel back and tapered side splashes
- Spatula wide 3½" grease gutter and chute is fully welded for easier cleaning and to stop grease migration
- One 27,000 BTU/hr. "U" shaped aluminized steel burner for every 12" of griddle width
- One embedded snap action thermostat per burner with temperature adjust from 200°F to 550°F
- Large 6 quart stainless steel grease drawer (2 drawers on 60" and 72" models)
- Heavy duty chromed thermostat knob guards
- One pilot safety valve for every two burners; safety will completely shut off gas to pilot and burners if pilot extinguishes
- Manual shut-off valve for gas inlet
- Dual (manual/electric) ignition
- Bottom heat shields
- ¾" rear gas connection and gas pressure regulator
- 120V 50/60Hz 1 Amp single phase with NEMA 5-15 USA plug
- One year limited parts and labor warranty

OPTIONS

- Hexavalent chrome plated cooking surface
- 30" deep plate
- Stainless steel stand with marine edges and casters
- Cutting board, condiment rail, plate rail and banking strip accessories
- Full or partially grooved griddle plate

900RX SERIES – Heavy Duty Gas Griddles

Approved by _____ Date _____ Approved by _____ Date _____

INSTALLATION INSTRUCTIONS INSTALLATION MANUAL

1. A gas pressure regulator supplied with the unit must be installed;
Natural Gas 4.0" (102 mm) W.C.
Propane Gas 10.0" (254 mm) W.C.
2. All models require a 6" (152 mm) clearance at both sides and rear adjacent to combustible and 0" from non-combustible constructions. All models require a 4" (102mm) bottom clearance and must be installed with minimum 4" legs.
3. These units are manufactured for installation in accordance with ANSI/NFPA-70, National Electrical code.

An adequate ventilation system is required for Commercial Cooking Equipment (NFPA No. 96). Information may be obtained by writing to the National Fire Protection Association, Batterymarch Park, Quincy, MA 02169.

4. These units are manufactured for installation in accordance with National Fuel Gas Code, ANSI-Z223.1/NFPA #54 (latest edition). Copies may be obtained from The American Gas Association, Accredited Standards Committee Z223 @ 400 N. Capital St. NW, Washington, DC 20001, or the Secretary Standards Council, NFPA, 1 Batterymarch Park, Quincy, MA 02169-7471.

NOTE: In The Commonwealth of Massachusetts

All gas appliances vented through ventilation hood or exhaust system equipped with a damper or with a power means of exhaust shall comply with 248 CMR.

5. This appliance is manufactured for commercial installation only and is not intended for home use.

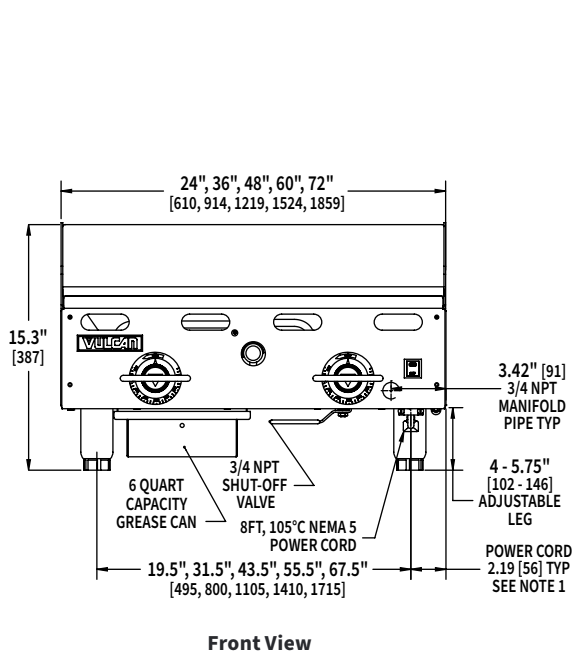

- NOTES:**
1. 2.19" FROM RIGHT FOR 24", 36" & 48" GRIDDLES
30.00" FROM RIGHT FOR 60" & 72" GRIDDLES
 2. ADJUSTABLE LEGS ARE 2" IN DIAMETER.
LEGS ARE RECESSED 1/4" FROM EACH SIDE.

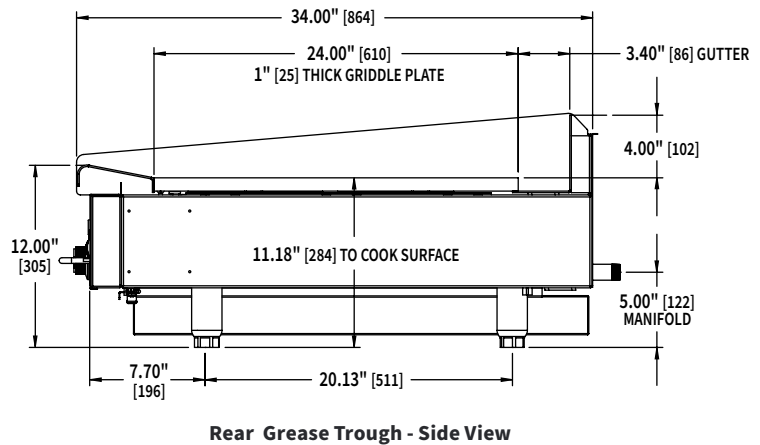
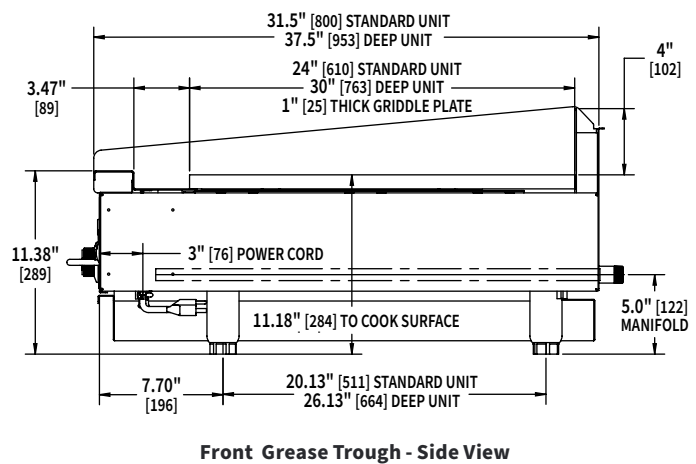

▶ CAD and/or Revit Files Available

Model	Width	Depth	Overall Height*	Working Height*	Number of Burners	Total BTU/Hr.	Number of Drawers	Approximate Shipping Weight
924RX	24"	31½"	15¼"	11⅞"	2	54,000	1	285 lbs./129 kg.
936RX	36"	31½"	15¼"	11⅞"	3	81,000	1	400 lbs./181 kg.
948RX	48"	31½"	15¼"	11⅞"	4	108,000	1	480 lbs./218 kg.
960RX	60"	31½"	15¼"	11⅞"	5	135,000	2	650 lbs./295 kg.
972RX	72"	31½"	15¼"	11⅞"	6	162,000	2	790 lbs./358 kg.

*These are nominal dimensions and can vary by +1.75" with adjustable legs.

As continued product improvement is a policy of Vulcan, specifications are subject to change without notice.