



Project \_\_\_\_\_  
 AIA # \_\_\_\_\_ SIS # \_\_\_\_\_  
 Item # \_\_\_\_\_ Quantity \_\_\_\_\_ C.S.I. Section 114000

## VEKT SERIES

### Electric Counter Kettle Table



Model VEKT26/6



### SPECIFIER STATEMENT

Electric counter kettle table Vulcan Model No. VEKT\_\_\_\_\_. Stainless steel top with marine edge on sides and rear, drain trough, sides, front, legs, flange and feet. Drain tray fits into the full length drain trough. Kettle(s) and braising pan(s) are field installed.

Classified by UL to NSF Std. #4.

### MODELS

- VEKT26/6** 26"w – one K6ETT – Electric Counter Tilting Kettle
- VEKT50/66** 50"w – two K6ETT – Electric Counter Tilting Kettle
- VEKT64/612** 64"w – one K6ETT and K12ETT – Electric Counter Tilting Kettle
- VEKT64/126** 64"w – one K12ETT and K6ETT – Electric Counter Tilting Kettle
- VEKT64/1212** 64"w – two K12ETT – Electric Counter Tilting Kettle
- VEKT80/666** 80"w – three K6ETT – Electric Counter Tilting Kettle

### STANDARD FEATURES

- Electric counter kettle table, stainless steel top with marine edge on sides and rear, drain trough, sides, front, legs, flange and feet.
- Drain tray fits into the full length drain trough.
- Kettle(s) are field installed.
- One year limited parts and labor warranty.

VEKT SERIES – Electric Counter Kettle Table

Approved by \_\_\_\_\_ Date \_\_\_\_\_ Approved by \_\_\_\_\_ Date \_\_\_\_\_

### SERVICE CONNECTIONS:

- A Electrical connections refer to appropriate spec sheet.
- B Drain for waste.
- C Water for swing faucet dual temperature, 3/8" IPS.

### NOTES

- Dimensions which locate the above connections have a tolerance of + or -3" (+ or -75 mm).
- Installation of backflow preventers, vacuum breakers and other specific code requirements is the responsibility of the owner and installer. It is the responsibility of the owner and installer to comply with local codes.

### IMPORTANT:

1. This appliance is manufactured for commercial installation only and is not intended for home use.
2. Refer to the appropriate spec sheet for a list of options and accessories:
  - Model K6ETT & K12ETT – F37450
  - Model VECTS12 – F31687
  - Model VECTS16 – F32279

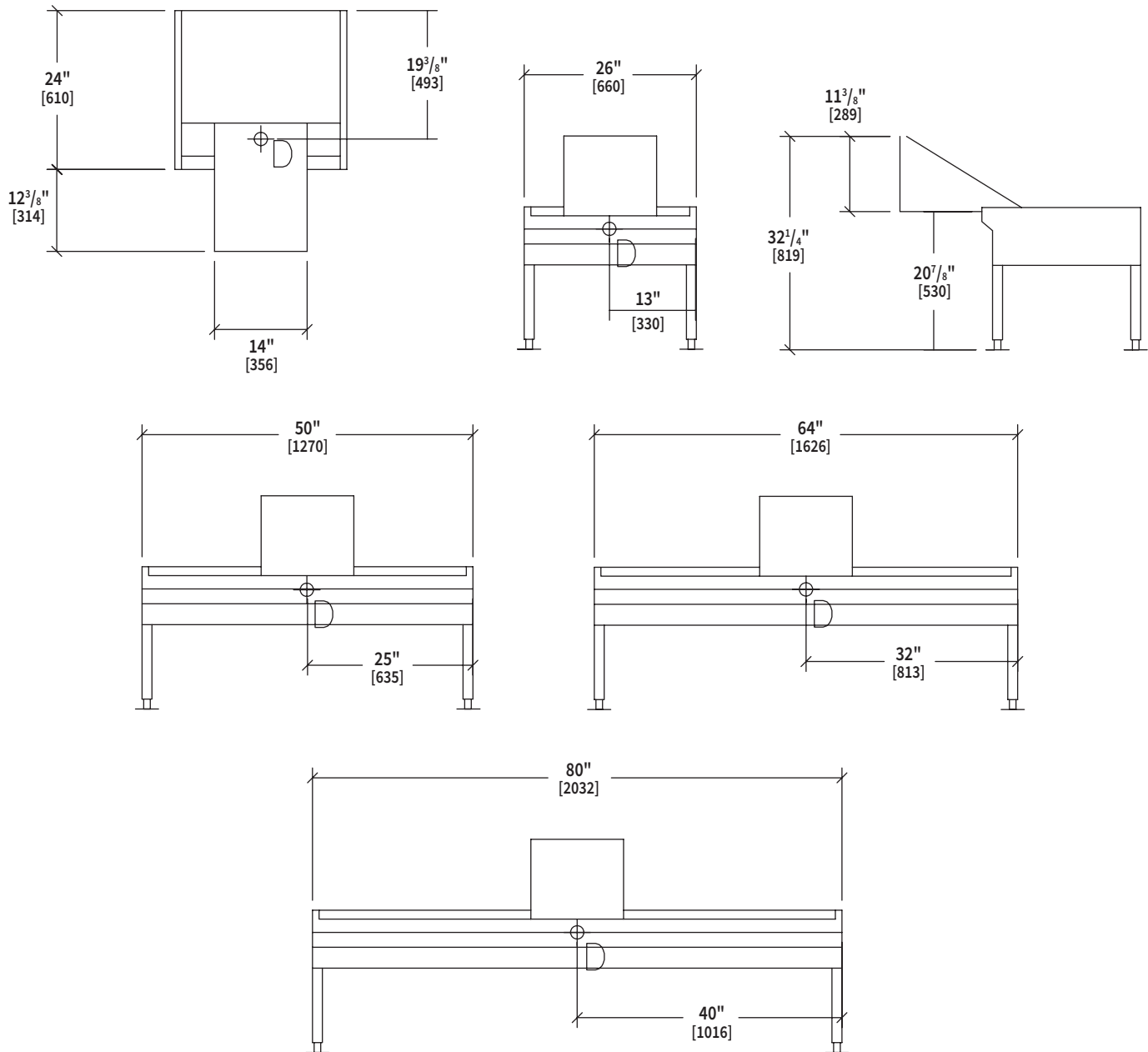

CAD and/or Revit Files Available

As continued product improvement is a policy of Vulcan, specifications are subject to change without notice.