

Converge® Multi-Cook Oven

UL Listed

Converge® Multi-Cook Ovens combine the flexibility of a multi-cook oven, power of Structured Air Technology®, and the versatility of combi cooking in each oven chamber. Controlled humidity to execute an all-day menu and boost production capacity. Increase production capacity without increasing labor. Two or three independent ovens in one give you the freedom to steam, air fry, bake, grill and more at the same time without flavor transfer—all in a ventless, self-cleaning design.

Control the temperature, fan speed, humidity level and cook time in each individual oven chamber.

Exclusive Structured Air Technology® delivers focused heat for faster, more even cooking and consistent, high-quality results.

Reduce labor by eliminating extra steps in food production and the need to watch and rotate pans.

An advanced control—designed intentionally simple—features an intuitive, user-friendly interface and programmable recipes to ensure consistency with each cook.

ChefLinc™, cloud-based remote oven management software, streamlines processes and maximizes profits with data-driven insights (deluxe control only).

ISO 9001:2015-certified.

Standard features

- Three cooking modes—steam, convection, and combination
- Single-point probe on Deluxe control models
- Programmable, touchscreen control
- Easy recipe upload/download via USB port
- Four fully automated cleaning cycles
- Integrated catalyst wash
- Front-accessible and retractable rinse hose
- LED illuminated door handle is designed for the needs of the busy kitchen, and provides visual notification of the oven status
- Absolute Humidity Control™ allows for selection any humidity level from 0-100% to maximize food quality, texture, and yield
- EPA 202 compliant



CAPACITY

- 2** CMC-H2H: 2 shelf, 2 full-size steam pans—20-3/4" x 12-3/4" x 4" [2 GN 1/1 pans—530mm x 325mm x 100mm] or 2 half-size sheet pans—18" x 13" x 1" [2 GN 2/3 pans—354mm x 325mm x 25mm]
- 3** CMC-H3H: 3 shelf, 3 full-size steam pans—20-3/4" x 12-3/4" x 4" [3 GN 1/1 pans—530mm x 325mm x 100mm] or 3 half-size sheet pans—18" x 13" x 1" [3 GN 2/3 pans—354mm x 325mm x 25mm]



ALTO-SHAAM.



CMC-H3H



CMC-H2H

Configurations (select one)

Models

- CMC-H2H CMC-H3H

Control

- Deluxe Simple

Door swing

- Right hinged Left hinged

Electrical CMC-H2H

- 208–240V, 1PH, 50A, NEMA 6-50P plug
 208–240V, 3PH, 30A, NEMA 15-30P plug

Electrical CMC-H3H

- 208–240V, 3PH, 50A, NEMA 15-50P plug

Accessories (select all that apply)

Casters and legs

- Mobile base with 3" [76mm] casters [5031664]
 4" [110mm] adjustable legs, set of four [5031908]
 Seismic legs, set of four [5032087]

Cookware

- Pan, pizza screen 14" [PN-47175]
 Pan, grill, corrugated [PN-47173]
 Pan, egg, 6-count [PN-47177]
 Pan, egg, 9-count [PN-47178]
 Probe, T-shape [PR-37158]

Cleaning

- Automatic tablet-based cleaning system, standard
 Cleaner, non-caustic, 90 count tablet [CE-47853]
 Catalyst wash, descale, 30 count tablet, [CE-47859]

Water treatment

- RO system OPS175CR/5 [5031203]

Plumbing and Electric kit

- CPVC, 30A [5032853]
 CPVC, 40A [5032854]
 Copper, 30A [5032855]
 Copper, 40A [5032856]

Plumbing only kit

- CPVC [5033029]
 Copper [5033030]

Installation options (select one)

- Alto-Shaam Combination Factory Authorized Installation Program—available in the U.S. and Canada only
 Installation Start-Up Check—available through an Alto-Shaam authorized service agency

Converge® Multi-Cook Oven



CMC-H2H

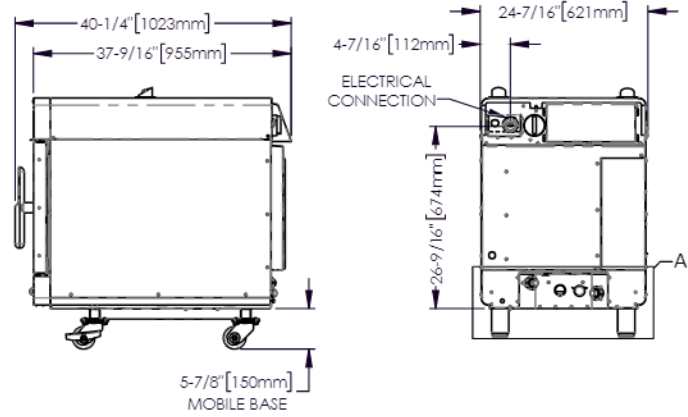
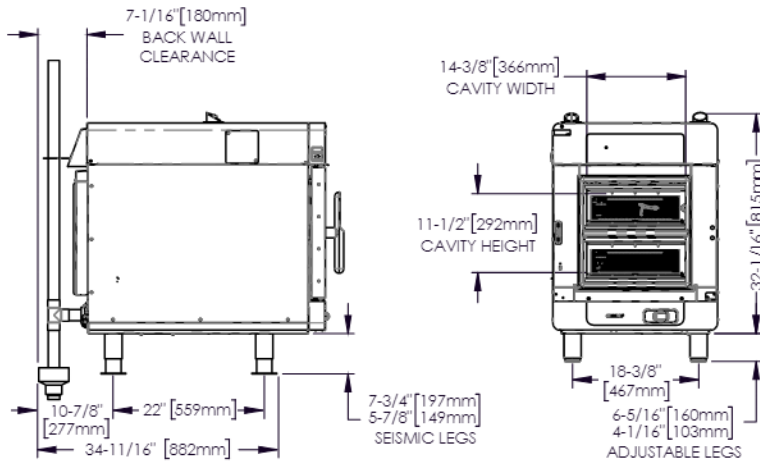
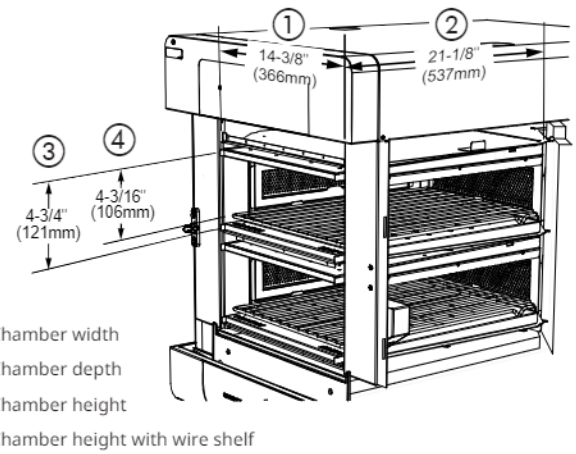
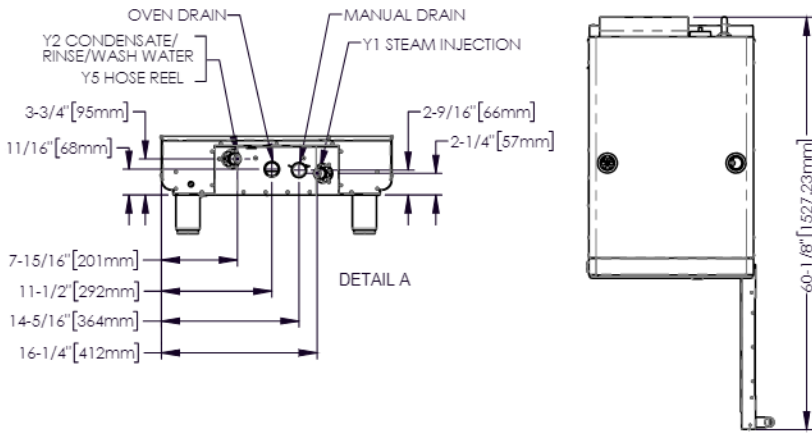

Model CMC-H2H **Exterior (H x W x D)**
 38-3/8" x 24-7/16" x 40-1/4" [975mm x 621mm x 1023mm]

Interior (H x W x D)
 11-1/2" x 14-3/8" x 21-1/8" [292mm x 366mm x 537mm]

Net Weight
 304 lb [138 kg]

Model CMC-H2H **Ship Dimensions (L x W x H)***
 48" x 29" x 56" [1219mm x 737mm x 1422mm]

Ship Weight
 400lb [181 kg]



CMC-H2H	V	Ph	Hz	Awg	IEC	A	Breaker (A)*	kW	Plug Configuration**
208-240V	208	1	50/60	6	—	32	50	6.7	NEMA 6-50P
	240	1	50/60	6	—	37	50	8.9	NEMA 6-50P
208-240V	208	3	50/60	8	—	19	30	6.7	NEMA 15-30P
	240	3	50/60	8	—	22	30	8.9	NEMA 15-30P

**Electrical connections must meet all applicable federal, state, and local codes.

* For use on individual branch circuit only.

Converge® Multi-Cook Oven



CMC-H3H

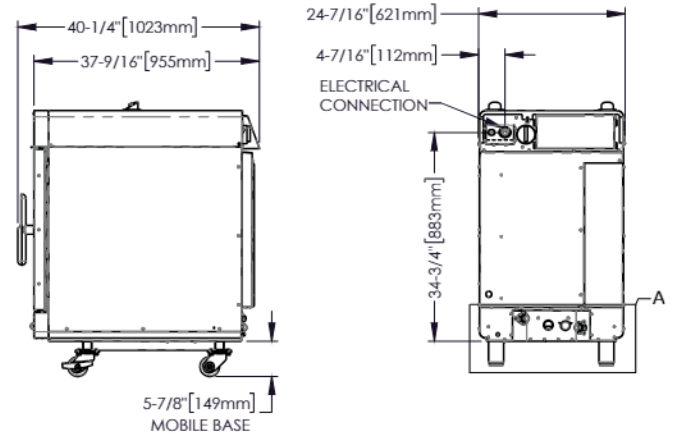
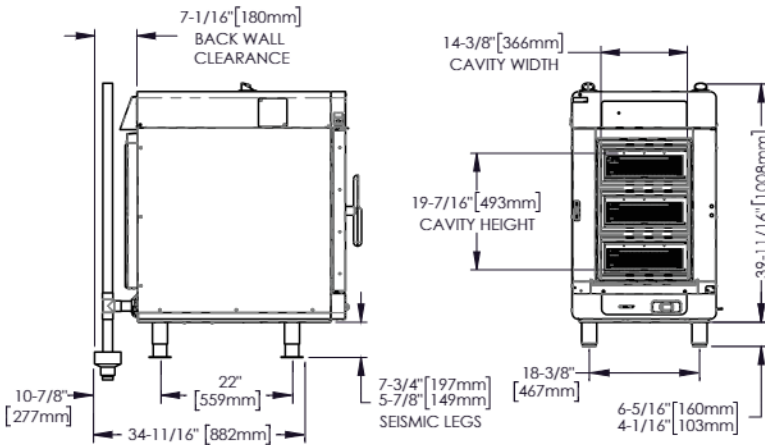
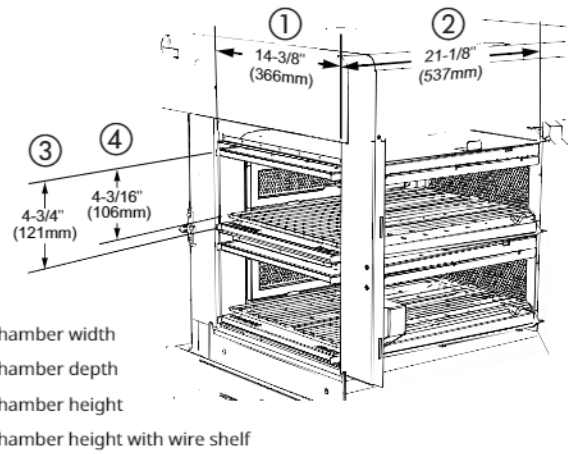
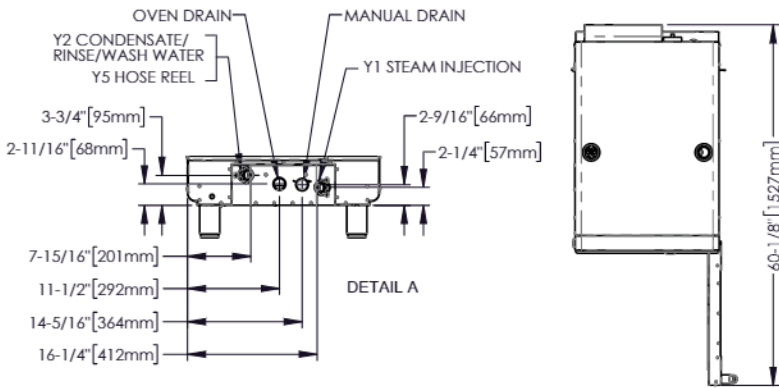

Model Exterior (H x W x D)
CMC-H3H 46" x 24-7/16" x 40-1/4" [1168mm x 621mm x 1023mm]

Interior (H x W x D)
19-7/16" x 14-3/8" x 21-1/8" [366mm x 373mm x 537mm]

Net Weight
394 lb [179 kg]

Model Ship Dimensions (L x W x H)*
CMC-H3H 48" x 29" x 56" [1219mm x 737mm x 1422mm]

Ship Weight
490 lb [222 kg]



CMC-H3H	V	Ph	Hz	Awg	IEC	A	Breaker (A)*	kW	Plug Configuration**
208-240V	208	3	50/60	6	—	28	50	10.1	NEMA 15-50P
	240	3	50/60	6	—	32	50	13.4	NEMA 15-50P

**Electrical connections must meet all applicable federal, state, and local codes.

* For use on individual branch circuit only.



CLEARANCE

- Top: 2" (51mm)*
- Left: 2" (51mm)
- Right: 2" (51mm)
- Front: 20" (508mm)
- Back: 7-1/16" (179 mm)

* 18" (457mm) recommended for service access



CHECK FIRST

- The oven must be installed level.
- Water supply shut-off valve and back-flow preventer when required by local code.
- Drain must not be located directly underneath the appliance.
- Oven not intended for built-in installation.



HEAT

Heat of rejection

	Heat Gain qs, BTU/hr	Heat Gain qs, kW
CMC-H2H	471	0.14
CMC-H3H	706	0.21



NOISE

Noise emissions

Without hood system, a maximum 63.3 dBA was measured at 3.3 ft [1 m] from unit.



WATER

Water requirements (per oven)

- Two cold water inlets - drinking quality
- One treated water inlet: 3/4" NPT male connection. Line pressure 30 psi [200 kPa] minimum dynamic and 145 psi [1000 kPa] maximum static—at a minimum flow rate of 0.16 gpm [0.6 L/min].
- One untreated water inlet: 3/4" NPT male connection. Line pressure 30 psi [200 kPa] minimum dynamic and 145 psi [1000 kPa] maximum static at a minimum flow rate of 4 gpm [15 L/min].
- Water drain: 1-1/2" [40mm] connection with a vertical vent to extend above the exhaust vent. Materials must withstand temperatures up to 200°F [93°C].
- Water supply connections to be 3/4" NPT male fittings.

Water Quality Standards

It is the sole responsibility of the owner/operator/purchaser of this equipment to verify that the incoming water supply is comprehensively tested and, if required, a means of "water treatment" provided that would meet compliance requirements with the published water quality standards shown below. Non-compliance with these minimum standards will potentially damage this equipment and/or components and void the original equipment manufacturer's warranty. Alto-Shaam recommends using the Alto-Shaam Reverse Osmosis System to properly treat your water.

Inlet Water Requirements		
Contaminant	Treated Water	Untreated Water
Free Chlorine	Less than 0.1 ppm (mg/L)	Less than 0.1 ppm (mg/L)
Hardness	30-70 ppm	30-70 ppm
Chloride	Less than 30 ppm (mg/L)	Less than 30 ppm (mg/L)
pH	7.0 to 8.5	7.0 to 8.5
Silica	Less than 12 ppm (mg/L)	Less than 12 ppm (mg/L)
Total Dissolved Solids (tds)	50-125 ppm	50-360 ppm



CLEARANCE

Clearance requirements for water filtration system

Do not install a water filtration system behind unit.

CONTACT US

W164 N9221 Water Street | Menomonee Falls, Wisconsin 53051 | U.S.A.
 Phone: 262.251.3800 | 800.558.8744 U.S.A./Canada | Fax: 262.251.7067 | alto-shaam.com