

MOTAK

Double, Full-size Gas Convection Oven

Model #: **MCO-1-DBL**

This double, full-size gas convection oven is ideal for any high volume restaurant or food service establishment. Constructed of stainless steel, this oven operates with a forced air, two-speed fan motor system with a cool down feature. The interior of each oven has a 10-position rack guide and fits full size sheet pans. Electronic controls featuring 60-minute timers and manual temperature knobs. The double pane glass doors have an interlock switch that automatically turn the fan and burners off when they are opened. Includes stacking kit and casters.

Not suitable for installation in non-commercial or residential applications.



Product Details

Details below are for single convection ovens only. This is a double unit, so some details will vary.

Construction

- Stainless steel front
- Double pane thermal glass windows on doors
- Doors have an interlock switch that automatically turns the fan and burners off when open
- 3/4" rear NPT gas connection

Oven Features

- Easy to Clean Full Porcelain Oven Interior
- Oven interiors measure 28.25" x 21.5" x 20"
- 1/2 HP two speed fan motors
- Cooking chambers are lined with porcelain enamel
- 10 position guide racks with 1.5" spacing in between
- 5 heavy duty adjustable chrome plated racks per oven
- Seamless interior and corners for easy cleaning

Note: Double Deck ovens are shipped as single decks.

Controls

- Accurate solid state oven thermostat with a range from 150°F - 550°F
- 60 minute continuous ring timer - manual shut off
- Temperature ready indicator light
- 6' power cord with NEMA 5-15 Plug

Warranty

1 year parts & labor

MOTAK

Model #:
MCO-1-DBL

Double, Full-size Gas Convection Oven

Plan View

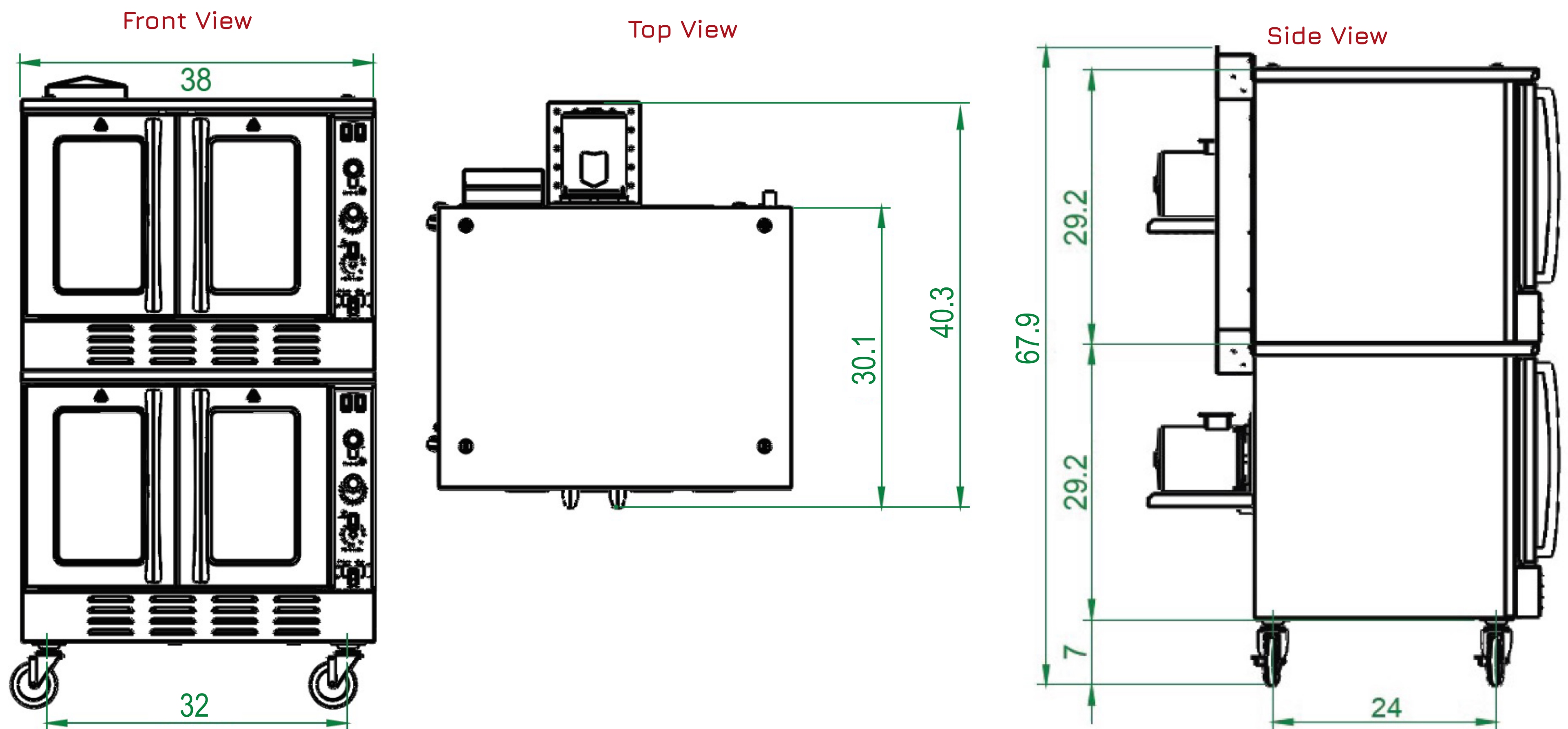

Specifications

*Specs shown below are for single convection ovens only. This is a double unit, so the specifications will vary.

Model	Racks* (per oven)	External Dimensions* (per oven)			Internal Oven Dimensions (per oven)			BTU* (Per Burner)	AMP* (per oven)	Volts (per oven)	Crated Weight* (lbs) (per oven)
		Width	Depth	Height*	Width	Depth	Height				
MCO-1-DBL	5	38"	40.3"	67.9"	28.5"	21.5"	20"	54,000	5.9	120V	605 lbs.

Not suitable for installation in non-commercial or residential applications.