

Upright Reach-Ins

BOTTOM MOUNTED CONDENSING UNIT (EB SERIES)

Refrigerators / Freezers / Dual Temps



The Bottom Mounted Upright Reach-In series offers temperature combinations and door variations in a bottom breathing design. Its deep cabinet interior is perfect for full-size baking sheet pans. It comes in solid, glass, full door, half door and drawer variations.



Blizzard R290

EPA/DOE approved, all-in-one, slide-out cooling cartridge.



Digital Control

Easy settings with audio and visual overheat alarm.



ECM Fan Motors

Electronically commutated motors require less energy.



All Stainless Steel

High quality finish with 2.5" thick thermal insulation.



Door Lock

Pre-installed, tamper-resistant, heavy-duty tumbler.



Vacuum Relief Valve

Equalizes cabinet pressure for smooth door re-entry.



Ridge-Lined Gasket

Heavy-duty door gaskets snap out/in for easy cleaning.

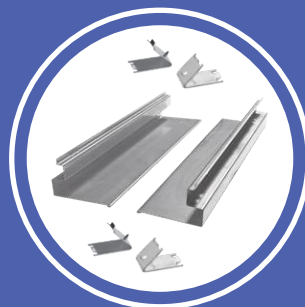

Sheet Pan Racks

Optional sheet pan rack assembly fits full-size pans..



Other Features

Self-closing door, LED lighting, 3" or 5" swivel casters.



EBWRFH2



EBSRF2



EBRF2



EBRF3

Cabinet Construction

- Heavy duty stainless steel interior / exterior with rounded corners for a hazard-free workspace.
- Insulated interior wall between refrigerator and freezer compartments.
- Galvanized steel top, bottom and rear.
- 2.5" thick high density polyurethane insulation.
- Deeper cabinet interior for more storage options.
- Four 5" swivel casters with locks on front set (six for model EBRF3). Leg stabilizers standard for all models.

Refrigeration System

- Bottom mounted, self-contained and fully retractable Blizzard R290 condensing unit uses environmentally friendly, EPA-compliant R290 refrigerant with zero (0) Ozone Depletion Potential (ODP) and three (3) Global Warming Potential (GWP). Blizzard R290 is easily replaceable and requires no on-site brazing (does not apply to model EBWRFH2).
- Electronically commutated (ECM) fan motors achieve rapid cooling with less energy consumption.
- Full-length air duct and airflow guard ensure optimal cold air circulation.
- Air circulation guard keeps floor vents from obstruction (except EBWRFH2).
- Time-initiated and temperature-terminated auto defrost heater for freezers. Air defrost for refrigerators.
- Large capacity, corrosion-resistant condenser and evaporator coils.
- Self-maintaining, energy-efficient condensate drain pan requires no external drains or electric heaters.
- High performance, auto-reverse condenser fan motor supports compressor ventilation and condenser coil cleaning.
- Pressure relief devices allow rapid cabinet re-entry.
- Pre-wired and ready to plug, 115V/60Hz/1Ph, NEMA 5-15P.

Lighting

- Energy efficient silicone coated and shatter-proof LED lighting provides bright, high color illumination with low heat output.

Doors

- Heavy duty stainless steel interior / exterior.
- 2.5" thick high density polyurethane insulation.
- Frame heaters prevent exterior moisture build up.
- Self-closing with adjustable torsion system for a positive seal.
- Snap-in magnetic gasket for ease of cleaning.
- High strength, recessed handles.
- Pre-installed locks keep your items safe from theft.
- Field reversible.

Shelving

- Epoxy coated, steel wire shelves (see table for quantity).
- Height adjustable stainless steel clips.

Temperature Control

- Multi-function digital controller with easy to read LED display.
- Factory preset temperature, 35°F for refrigerators and -4°F for freezers. Temp-set range from 33°F to 54°F for refrigerators and -10°F to 54°F for freezers.
- Audible overheat protection alarm for compressor and condenser coil.

Options

- Additional shelving.
- Baking sheet pan racks.
- 3" swivel casters with locks (does not apply to model EBWRFH2).
- 3.5" – 6" height-adjustable and interchangeable legs.
- Left hinged door.

↔ = Interior Dimensions ← = Exterior Dimensions

ABS Legs



Two additional front adjustable stainless steel clad ABS legs provide extra stability when opening and closing door, and three additional legs for EBRF3 for weight support.

Vacuum Relief



The vacuum relief valve equalizes cabinet pressure for rapid door re-entry.



Equipped with 9 ft long NEMA 5-15P plug.

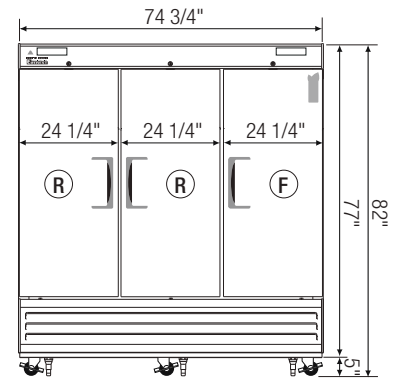
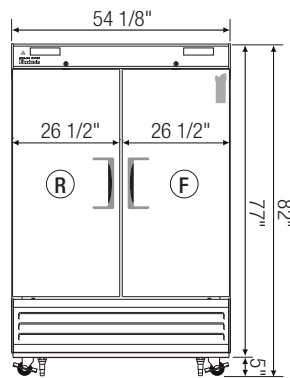
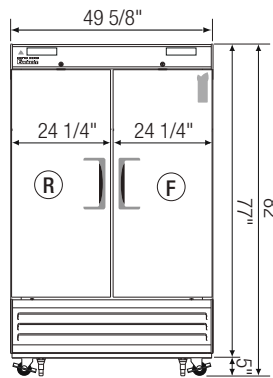
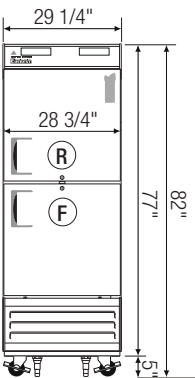
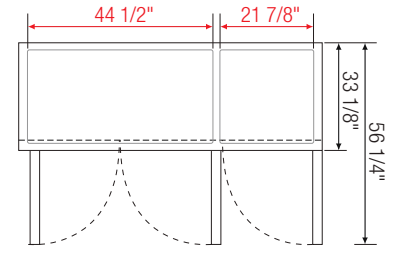
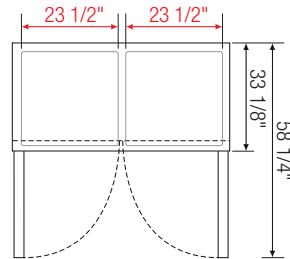
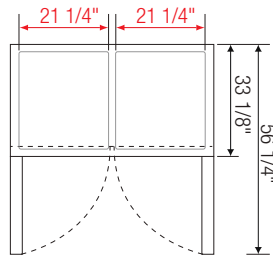
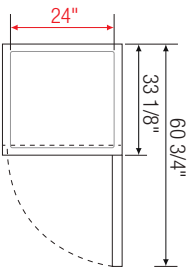
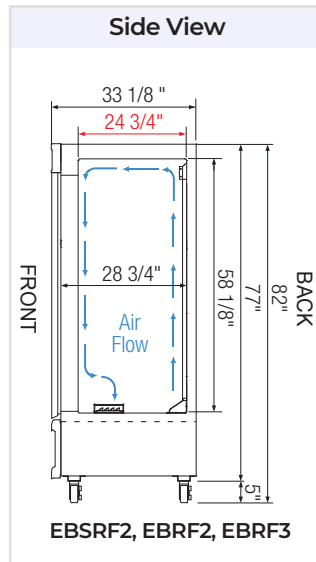
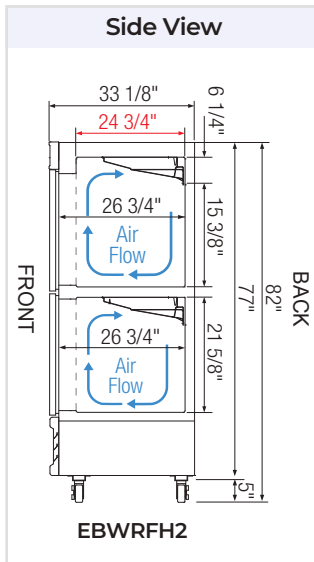

EBWRFH2

EBSRF2

EBRF2

EBRF3

Model	Ref/ Frz/ Dual	# of Doors	Capacity† (Cu. Ft.)	HP	BTU/HR †	Refrigerant	# of Shelves	Power (V-Hz-Ph)	Amps	Crated Weight (LBS)	Exterior Dimensions (Inches)		
											L	D	H*
EBWRFH2	Dual	2 (H)	11 (R) 11 (F)	1/2	1,670	R290	2	115-60-1	5	341	29 1/4	33 1/8	77
EBSRF2	Dual	2	22 (R) 22 (F)	1/4+ (R) 1/2 (F)	1,672 (R) 1,670 (F)	R290	6	115-60-1	5	546	49 5/8	33 1/8	77
EBRF2	Dual	2	22 (R) 22 (F)	1/4+ (R) 1/2 (F)	1,672 (R) 1,670 (F)	R290	6	115-60-1	8	613	54 1/8	33 1/8	77
EBRF3	Dual	3	46 (R) 22 (F)	1/3+ (R) 1/2 (F)	2,612 (R) 1,670 (F)	R290	9	115-60-1	8	698	74 3/4	33 1/8	77

* Height does not include 5" for casters.

† Based on evaporating temperature of 23°F (-5°C) & condensing temperature of 131°F (55°C).

Ref = Refrigerator | Dual = Ref & Frz Combo
(H) = Half Door | (F) = Freezer

Specifications subject to change without notice.

Product dimensions are for general purposes and not absolute value. Product capacity (†) is calculated based on standard industry figures. Slight variations may exist. If dimensions and capacity are critical, please contact Everest Refrigeration.