

# Open Air Merchandisers

**BOTTOM MOUNTED CONDENSING UNIT (EOM SERIES)**

Refrigerators



The Open Air Merchandiser series conforms to NSF 7 Type II, able to withstand a warmer maximum ambient temperature of 80°F - higher than other comparable brands. It comes fully equipped with an array of standard features that other manufacturers charge extra for. Available in vertical and horizontal styles.



**NSF7 Type II**

Withstands a warmer ambient temperature of 80°F.



**Built-In Night Curtain**

Pulls down and latches for security & energy efficiency.

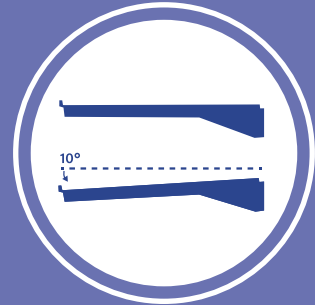

**Adjustable Shelves**

Height & tilt adjustable for better product visibility.



**Price Tag Moldings**

Keeps price tag inserts neat and organized.



**Bumper Belt**

Protects against shopping cart impact.



**Energy Efficient LED**

Under-shelf and canopy LEDs. High lumen, low heat.



**Blizzard R290**

EPA/DOE approved, all-in-one, slide-out cooling cartridge.



**Digital Control**

Easy settings with audio and visual overheat alarm.



**ECM Fan Motors**

Electronically commutated motors require less energy.

# Open Air Merchandisers – EOMV Series

Vertical / 28" Deep / Tall



EOMV-36-W-28-T



EOMV-36-B-28-T



EOMV-48-W-28-T



EOMV-48-B-28-T



EOMV-60-W-28-T



EOMV-60-B-28-T



EOMV-72-W-28-T



EOMV-72-B-28-T

## Cabinet Construction

- Black or white modern exterior has moisture-resistant panels and field-replaceable tempered glass.
- Heavy-duty stainless steel interior has perforated back wall for efficient air flow. Includes floor drains for ease of cleaning.
- Front stainless steel bumper belt protects against shopping cart impact.
- Galvanized steel top, bottom and rear.
- 2.5" thick high-density polyurethane insulation.
- Integrated retractable night curtain saves energy and provides security.
- 5" swivel casters with locks on front set. Leg stabilizers included.

## Refrigeration System

- Bottom mounted, self-contained and fully detachable Blizzard R290 condensing unit uses environmentally friendly, EPA-compliant R290 refrigerant with zero (0) Ozone Depletion Potential (ODP) and three (3) Global Warming Potential (GWP). Blizzard R290 is easily replaceable and requires no on-site brazing.
- Front air intake and rear air discharge design allows side by side installation.
- Electronically commutated (ECM) evaporator fan motors achieve rapid cooling with less energy consumption.
- High performance, auto-reverse condenser fan motor supports compressor ventilation and condenser coil cleaning.
- Large capacity, corrosion-resistant condenser and evaporator coils.
- Self-maintaining, energy-efficient condensate drain pan requires no external drains or electric heaters.
- Pre-wired and ready to plug, 115V/60Hz/1Ph, NEMA 5-20P and 230V/60Hz/1Ph, NEMA 6-20P (see table for plug types).

## Lighting

- Shielded LED bar lighting under shelves and canopy provide bright, high color illumination at lower heat output. On/off switch saves energy.

## Shelving

- Height and angle adjustable. Position it flat or slanted at 10°.
- Heavy duty stainless steel shelves include price tag moldings.

## Temperature Control

- Factory preset temperature of 35°F maintains a combined average product temperature of 40°F or less.
- Audible overheat protection alarm for compressor and condenser coil.

## Recommended Operating Conditions

- Conforms to NSF standard 7 TYPE II designed to operate in an air-conditioned environment where temperature and humidity do not exceed 80°F and 55% respectively.
- Must not be installed near ventilation systems, fans or exterior doors or windows that will disrupt the air curtain.
- Must not be installed in direct sunlight.
- In built-in applications, a distance of 6" is required on the front, back and top exterior for ventilation purposes.

## Option

- Roll-up metal shutters with security lock add an extra layer of protection.

↔ = Interior Dimensions   ← → = Exterior Dimensions

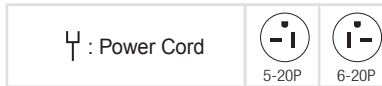
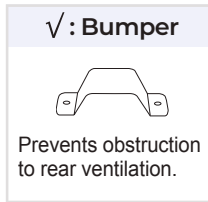
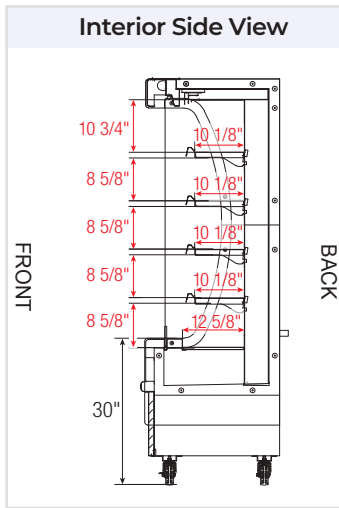
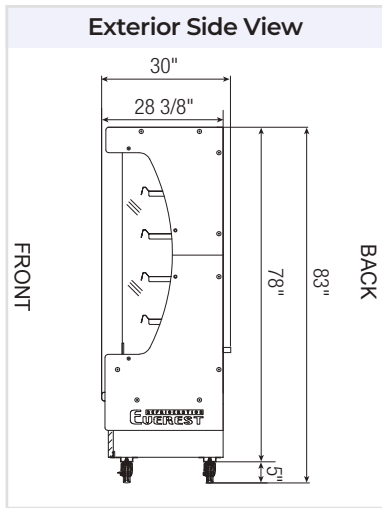

Equipped with 9 ft long NEMA 5-20P or 6-20P plug. See table below.

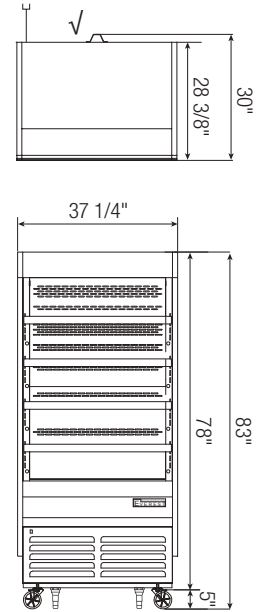

EOMV-36-W(B)-28-T

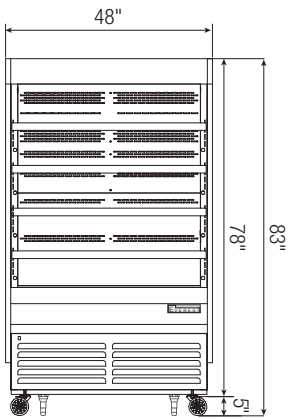
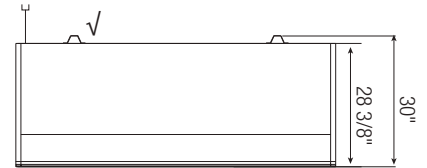
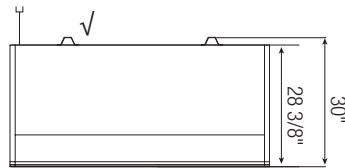
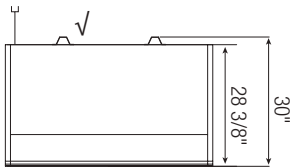

EOMV-48-W(B)-28-T

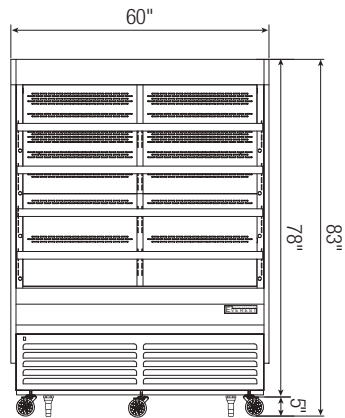

EOMV-60-W(B)-28-T

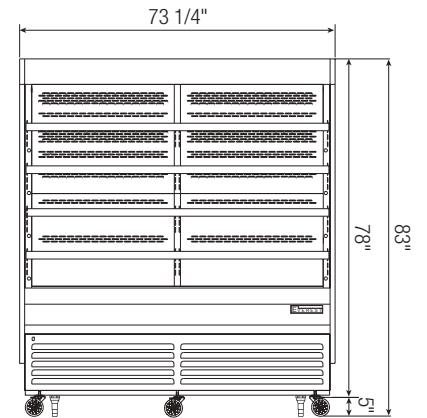

EOMV-72-W(B)-28-T

Model	Ref/ Frz/ Dual	Capacity <sup>†</sup> (Cu. Ft.)	HP	Refrigerant	# of Shelves	Power (V-Hz-Ph)	Amps	NEMA Config.	Crated Weight (LBS)	Exterior Dimensions (Inches)		
										L	D	H*
EOMV-36-W(B)-28-T	Ref	13	3/4	R290	4	115-60-1	8	5-20P	642	37 1/4	28 3/8	78
EOMV-48-W(B)-28-T	Ref	17	3/4 x 2	R290	4	115-60-1	14	5-20P	748	48	28 3/8	78
EOMV-60-W(B)-28-T	Ref	21	1x2	R290	8	230-60-1	8	6-20P	918	60	28 3/8	78
EOMV-72-W(B)-28-T	Ref	26	1x2	R290	8	230-60-1	8	6-20P	1085	73 1/4	28 3/8	78

\* Height does not include 5" for casters.

Ref = Refrigerator

Specifications subject to change without notice.

Product dimensions are for general purposes and not absolute value. Product capacity (†) is calculated based on standard industry figures. Slight variations may exist. If dimensions and capacity are critical, please contact Everest Refrigeration.