

Upright Reach-Ins

TOP MOUNTED CONDENSING UNIT (ES SERIES)

Refrigerators / Freezers / Dual Temps



The Top Mounted Upright Reach-In series offers a number of refrigerator, freezer and dual temperature combinations in solid, glass, full door, half door and drawer variations.

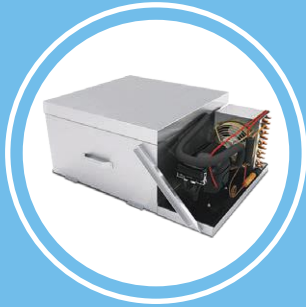

Blizzard R290

EPA/DOE approved, all-in-one, slide-out cooling cartridge.



Digital Control

Easy settings with audio and visual overheat alarm.



ECM Fan Motors

Electronically commutated motors require less energy.

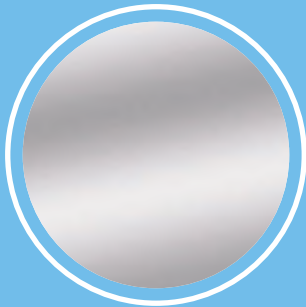

All Stainless Steel

High quality finish with 2.5" thick thermal insulation.



Door Lock

Pre-installed, tamper-resistant, heavy-duty tumbler.



Vacuum Relief Valve

Equalizes cabinet pressure for smooth door re-entry.

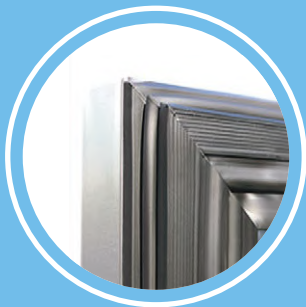

Ridge-Lined Gasket

Heavy-duty door gaskets snap out/in for easy cleaning.

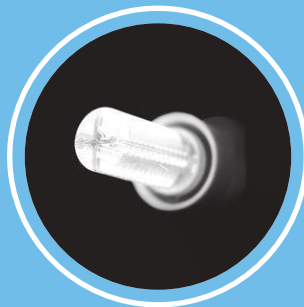

Energy Efficient LED

Silicone coated or shielded. High lumen rating, low heat.



Other Features

Self-closing doors, 3" or 5" swivel casters.

Upright Reach-In Dual Temps – ES Series

Top Mounted Condensing Unit



ESRFH2

ESRF2A



ESWRF2

ESWQ3



ESRF3

Cabinet Construction

- Heavy duty stainless steel interior / exterior with rounded corners for a hazard-free workspace.
- Insulated interior wall between refrigerator and freezer compartments.
- Galvanized steel top, bottom and rear.
- 2.5" thick high density polyurethane insulation.
- Four 5" swivel casters with locks on front set. Leg stabilizers standard for model ESRFH2..

Refrigeration System

- Top mounted, self-contained and fully detachable Blizzard R290 condensing unit uses environmentally friendly, EPA-compliant R290 refrigerant with zero (0) Ozone Depletion Potential (ODP) and three (3) Global Warming Potential (GWP). Blizzard R290 is easily replaceable and requires no on-site brazing (does not apply to model ESRFH2).
- Electronically commutated (ECM) fan motors achieve rapid cooling with less energy consumption.
- Full-length air duct and airflow guard ensure optimal cold air circulation.
- Time-initiated and temperature-terminated auto defrost heater for freezers. Air defrost for refrigerators.
- Large capacity, corrosion-resistant condenser and evaporator coils.
- Self-maintaining, energy-efficient condensate drain pan requires no external drains or electric heaters.
- High performance, auto-reverse condenser fan motor supports compressor ventilation and condenser coil cleaning.
- Pressure relief devices allow rapid cabinet re-entry.
- Pre-wired and ready to plug, 115V/60Hz/1Ph, NEMA 5-15P.

Lighting

- Energy efficient silicone coated and shatter-proof LED lighting provides bright, high color illumination with low heat output.

Doors

- Heavy duty stainless steel interior / exterior.
- 2.5" thick high density polyurethane insulation.
- Frame heaters prevent exterior moisture build up.
- Self-closing with adjustable torsion system for a positive seal.
- Snap-in magnetic gasket for ease of cleaning.
- High strength, recessed handles.
- Pre-installed locks keep your items safe from theft.
- Field reversible (does not apply to model ESWQ3).

Shelving

- Epoxy coated, steel wire shelves (see table for quantity).
- Height adjustable stainless steel clips.

Temperature Control

- Multi-function digital controller with easy to read LED display.
- Factory preset temperature, 35°F for refrigerators and -4°F for freezers. Temp-set range from 33°F to 54°F for refrigerators and -10°F to 54°F for freezers.
- Audible overheat protection alarm for compressor and condenser coil.

Options

- Additional shelving.
- 3" swivel casters with locks (does not apply to model ESRFH2).
- 3.5" – 6" height-adjustable and interchangeable legs.
- Left hinged door (does not apply to model ESWQ3).

↔ = Interior Dimensions ←→ = Exterior Dimensions

ABS Legs



Two additional front adjustable stainless steel clad ABS legs for model ESRFH2 provide extra stability when opening and closing doors.



Equipped with 9 ft long NEMA 5-15P plug.

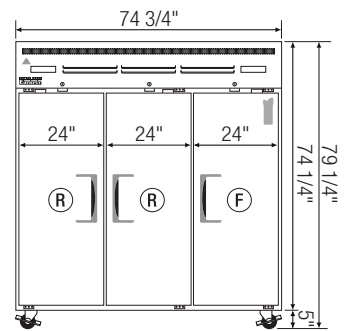
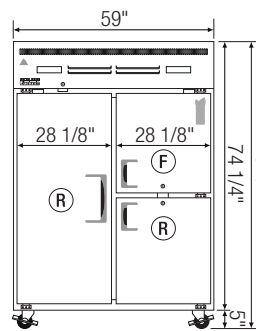
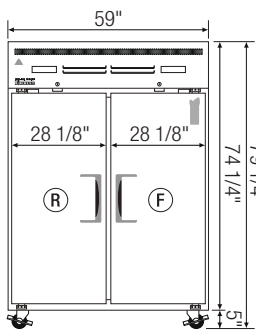
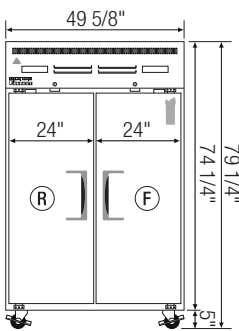
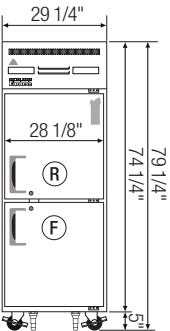
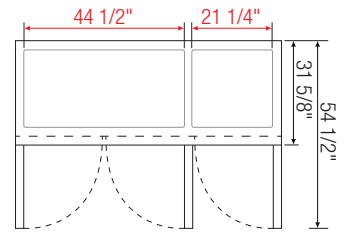
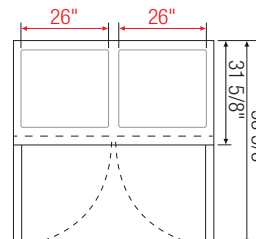
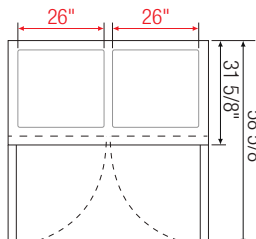
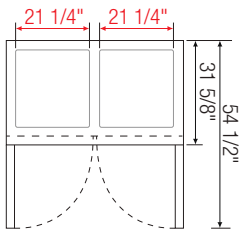
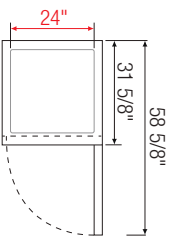
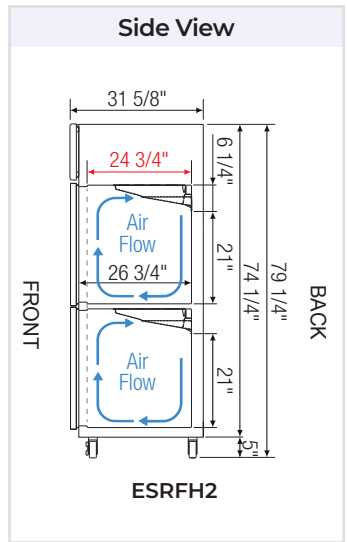
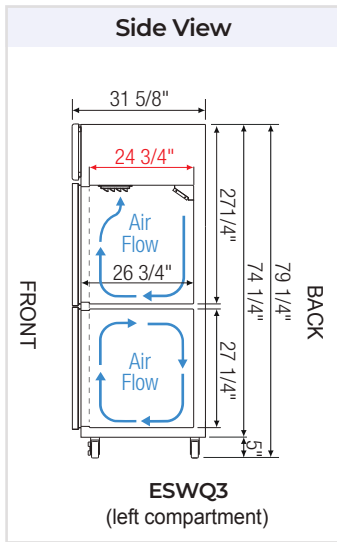
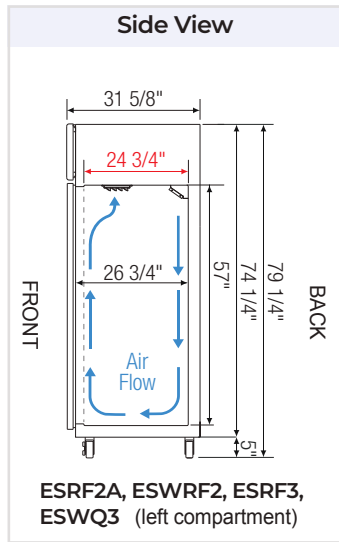

ESRFH2

ESRF2A

ESWRF2

ESWQ3

ESRF3

Model	Ref/ Frz/ Dual	# of Doors	Capacity [†] (Cu. Ft.)	HP	BTU/HR [†]	Refrigerant	# of Shelves	Power (V-Hz-Ph)	Amps	Crated Weight (LBS)	Exterior Dimensions (Inches)		
											L	D	H*
ESRFH2	Dual	2 (H)	11 (R) 11 (F)	1/2	1,670	R290	2	115-60-1	5	343	29 1/4	31 5/8	74 1/4
ESRF2A	Dual	2	22 (R) 22 (F)	1/4+ (R) 1/2 (F)	1,926 (R) 1,670 (F)	R290 R290	6	115-60-1	9	500	49 5/8	31 5/8	74 1/4
ESWRF2	Dual	2	26 (R) 26 (F)	1/4+ (R) 1/2 (F)	1,926 (R) 1,670 (F)	R290 R290	6	115-60-1	9	529	59	31 5/8	74 1/4
ESWQ3	Dual	2 (H) 1 (FD)	39 (R) 13 (F)	1/4+ (R) 1/3 (F)	1,926 (R) 1,119 (F)	R290 R290	5	115-60-1	5.5	524	59	31 5/8	74 1/4
ESRF3	Dual	3	46 (R) 22 (F)	1/4+ (R) 1/2 (F)	1,926 (R) 1,670 (F)	R290 R290	9	115-60-1	9	654	74 3/4	31 5/8	74 1/4

* Height does not include 5" for casters.

† Based on evaporating temperature of 23°F (-5°C) & condensing temperature of 131°F (55°C).

(R) = Refrigerator | (F) = Freezer | Dual = Ref & Frz Combo
(FD) = Full Door | (H) = Half Door

Specifications subject to change without notice.

Product dimensions are for general purposes and not absolute value. Product capacity (†) is calculated based on standard industry figures. Slight variations may exist. If dimensions and capacity are critical, please contact Everest Refrigeration.