

Undercounters

BACK MOUNTED CONDENSING UNIT (ETB SERIES)

Refrigerators / Freezers



The Back Mounted Undercounter series is designed to fit under counters or be used as a tabletop workspace. Its front-breathing condensing unit allows installation against walls or in counters. It comes in solid door and drawer variations.



Front Breathing

Allows installation against walls or in counters.

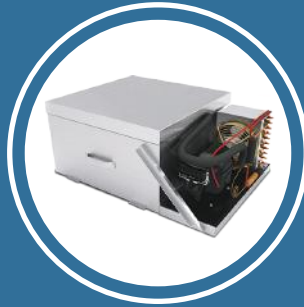

Blizzard R290

EPA/DOE approved, all-in-one, slide-out cooling cartridge.



Digital Control

Easy settings with audio and visual overheat alarm.



ECM Fan Motors

Electronically commutated motors require less energy.

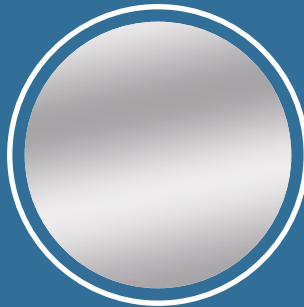

All Stainless Steel

High quality finish with 2.5" thick thermal insulation.

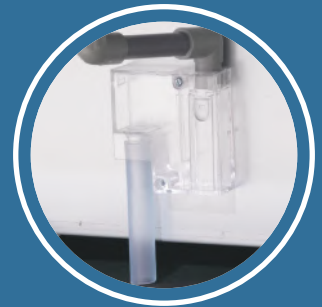

Vacuum Relief

Equalizes cabinet pressure for smooth door re-entry.

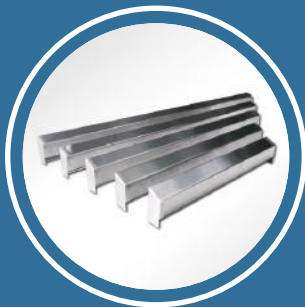

Optional Backsplash

Pre-installed & sealed 4" high stainless steel barrier.



Optional Overshelf

Stainless steel double overshelf for additional storage.



Other Features

LED lighting, lockable door, 3" or 5" swivel casters.

Drawered Undercounter Refrigerators – ETB Series

Back Mounted Condensing Unit



ETBR1-D2



ETBSR2-D2



ETBR2-D4



ETBWR2-D4



ETBR3-D2

Cabinet Construction

- Heavy duty stainless steel interior / exterior with rounded corners for a hazard-free workspace.
- Open spaced interior with no walls between compartments.
- 16 gauge, high quality stainless steel worktop.
- Galvanized steel bottom and rear.
- 2.5" thick high density polyurethane insulation.
- Four 5" swivel casters with locks on front set.

Refrigeration System

- Back mounted, self-contained and fully detachable Blizzard R290 condensing unit uses environmentally friendly, EPA-compliant R290 refrigerant with zero (0) Ozone Depletion Potential (ODP) and three (3) Global Warming Potential (GWP). Blizzard R290 is easily replaceable and requires no on-site brazing.
- Front air breathing for flexibility in installation.
- Electronically commutated (ECM) fan motors achieve rapid cooling with less energy consumption.
- Full-length air duct ensures optimal cold air circulation.
- Time-initiated and temperature-terminated auto defrost cycle for seamless operation.
- Large capacity, corrosion-resistant condenser and evaporator coils.
- Self-maintaining, energy-efficient condensate drain pan requires no external drains or electric heaters.
- High performance, auto-reverse condenser fan motor supports compressor ventilation and condenser coil cleaning.
- Pressure relief devices allow rapid cabinet re-entry.
- Pre-wired and ready to plug, 115V/60Hz/1Ph, NEMA 5-15P.

Doors & Drawers

- Heavy duty stainless steel interior / exterior.
- 2.5" thick high density polyurethane insulation.
- Thick gauge, stainless steel drawer frames with low-friction ball bearings.
- Self-closing door with adjustable torsion system for a positive seal.
- Snap-in magnetic gaskets for ease of cleaning.
- High strength, recessed handles.

Shelving

- Two epoxy coated, steel wire shelves (applies to model ETBR3-D2).
- Height adjustable stainless steel clips.

Temperature Control

- Multi-function digital controller with easy to read LED display.
- Factory preset temperature, 35°F. Temp-set range from 33°F to 54°F.
- Audible overheat protection alarm for compressor and condenser coil.

Options

- 4" high stainless steel backsplash for worktop application.
- NSF certified stainless steel double overshelf (does not apply to ETBR1-D2).
- Additional shelving (applies to model ETBR3-D2).
- 3" swivel casters with locks.
- 3.5" – 6" height-adjustable and interchangeable legs.

← = Interior Dimensions ← = Exterior Dimensions

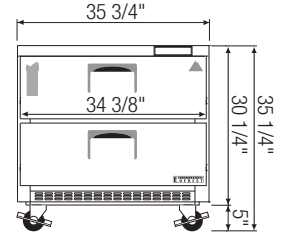
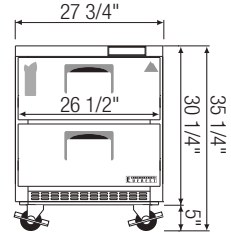
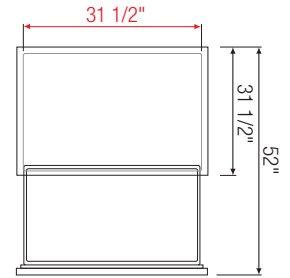
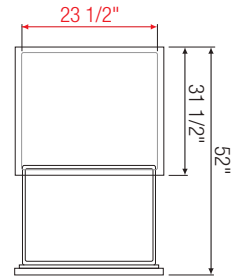
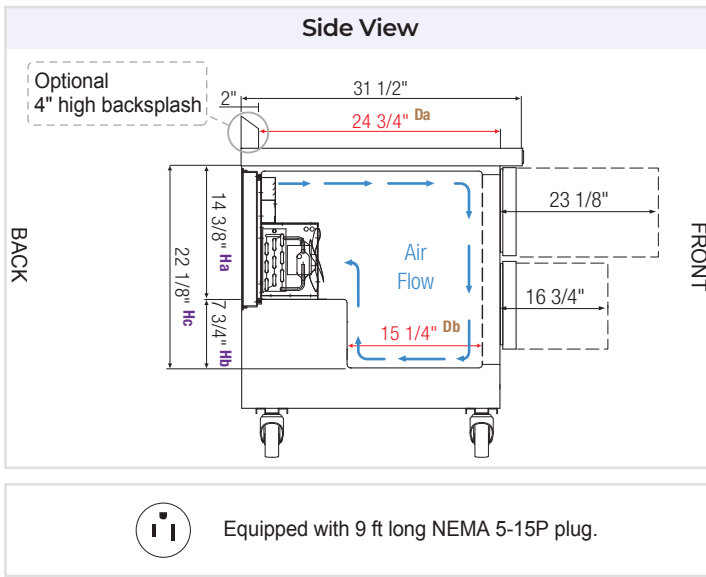

ETBR1-D2

ETBSR2-D2

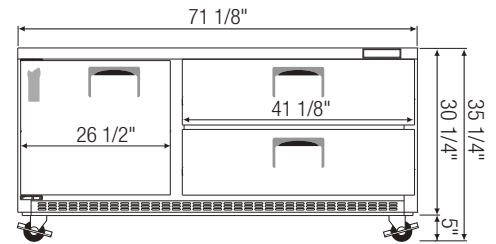
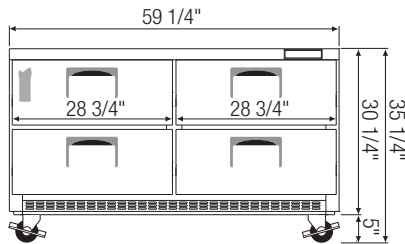
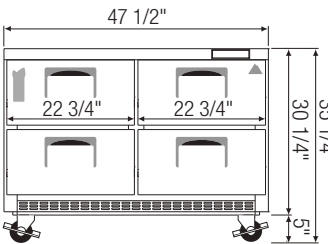
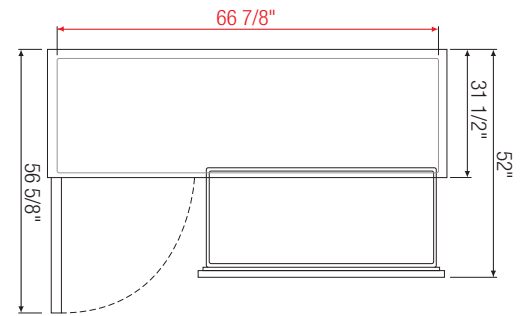
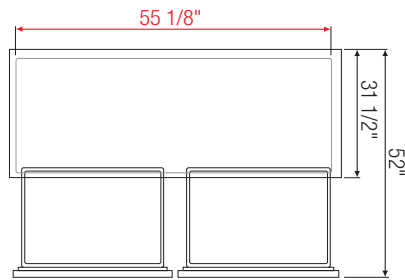
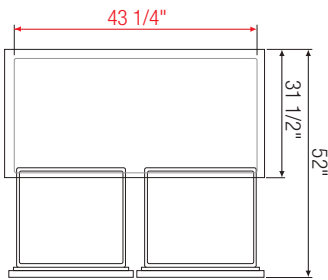

ETBR2-D4

ETBWR2-D4

ETBR3-D2

Model	Ref/ Frz/ Dual	# of Doors	Capacity [†] (Cu. Ft.)	HP	BTU/HR [†]	Refrigerant	# of Shelves	# of ^a Pans	Power (V-Hz-Ph)	Amps	Crated Weight (LBS)	Exterior Dimensions (Inches)		
												L	D	H*
ETBR1-D2	Ref	2(DR)	7.5	1/5	1,655	R290	N/A	1/2 x 4 1/4 x 2	115-60-1	2.5	204	27 3/4	31 1/2	30 1/4
ETBSR2-D2	Ref	2(DR)	10	1/5	1,655	R290	N/A	1/2x4, 1/3x2 1/4x2, 1/6x1	115-60-1	2.6	235	35 5/8	31 1/2	30 1/4
ETBR2-D4	Ref	4(DR)	14	1/5	1,655	R290	N/A	1/2x4, 1/3x4 1/4x2, 1/6x2	115-60-1	2.6	299	47 1/2	31 1/2	30 1/4
ETBWR2-D4	Ref	4(DR)	18	1/4+	1,926	R290	N/A	1/2x4, 1/3x8 1/4x2, 1/6x4	115-60-1	3.5	349	59 1/4	31 1/2	30 1/4
ETBR3-D2	Ref	1(D) 2(DR)	22	1/3	2,311	R290	2	1/2x2, 1/3x8 1/4x1, 1/6x4	115-60-1	3.7	374	71 1/8	31 1/2	30 1/4

* Height does not include 5" for casters.

† Based on evaporating temperature of 23°F (-5°C) & condensing temperature of 131°F (55°C).

^a Drawer pans are not included.

Da, Db Interior Depth Ha, Hb Interior Height

Specifications subject to change without notice.

Product dimensions are for general purposes and not absolute value. Product capacity (†) is calculated based on standard industry figures. Slight variations may exist. If dimensions and capacity are critical, please contact Everest Refrigeration.

Ref = Refrigerator | (DR) = Drawer | (D) = Door