

# MOTAK

## Chef Base Refrigerators

Model #: **MCBR72DX**

### Product Details

- Drawers with Heavy-duty sliders.
- Uses R290 refrigerant, which is eco-friendly and more efficient.
- Easy to access condenser coil for cleaning and service.
- Heavy-duty swivel casters are pre-installed.
- Electronic control system makes it easy to adjust temperature set point and defrost frequency.
- Refrigeration system keeps food at safe temperatures between 33°F and 41°F.
- Stainless steel top equipped with a marine edge enables the unit's top to contain drips and spills for easy cleanup.
- Stainless steel interior and exterior retains attractive finish longer. Matching aluminum finished back.

Not suitable for installation in non-commercial or residential applications.

### Warranty

WARRANTY: Drawers 1 year parts & labor, 2 year parts & labor warranty on the refrigeration system, and additional 3 years on compressor.

### Certifications

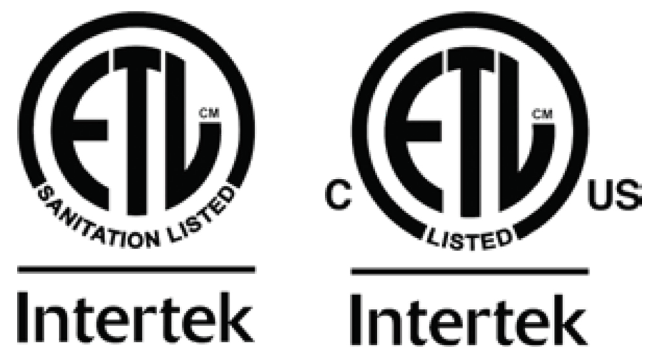

### Specifications

Model	Drawers	GN Pans	Cabinet Dims (in)			HP	Voltage	Amp	NEMA Plug	Cord Length (ft)	Ship Weight
			Width	Depth	Height						
MCBR72DX	4	8*1/1	72.375"	32.125"	25.875"	1/5	115/60/1	6.5	5-15P	10 ft.	397



### Plan View

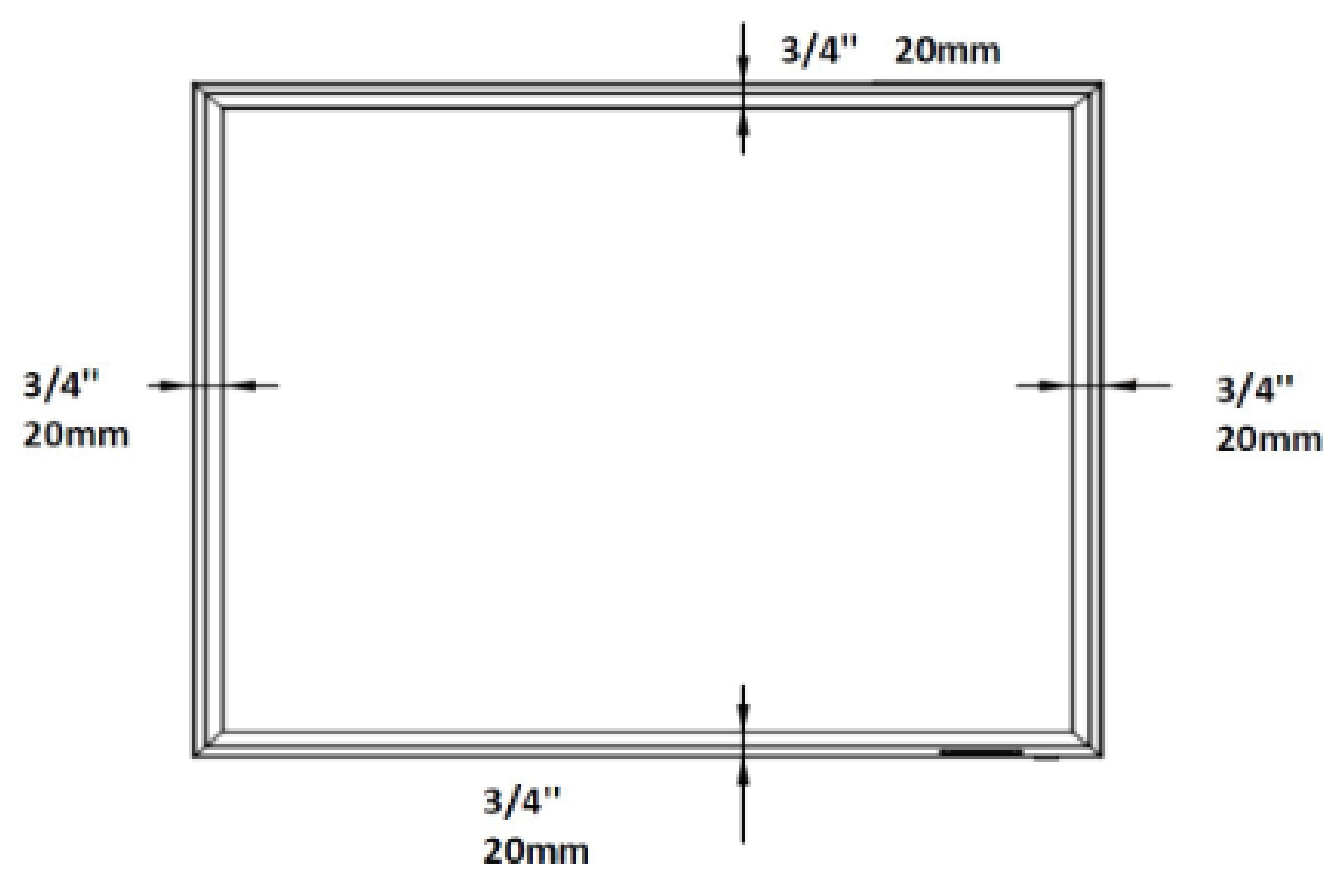
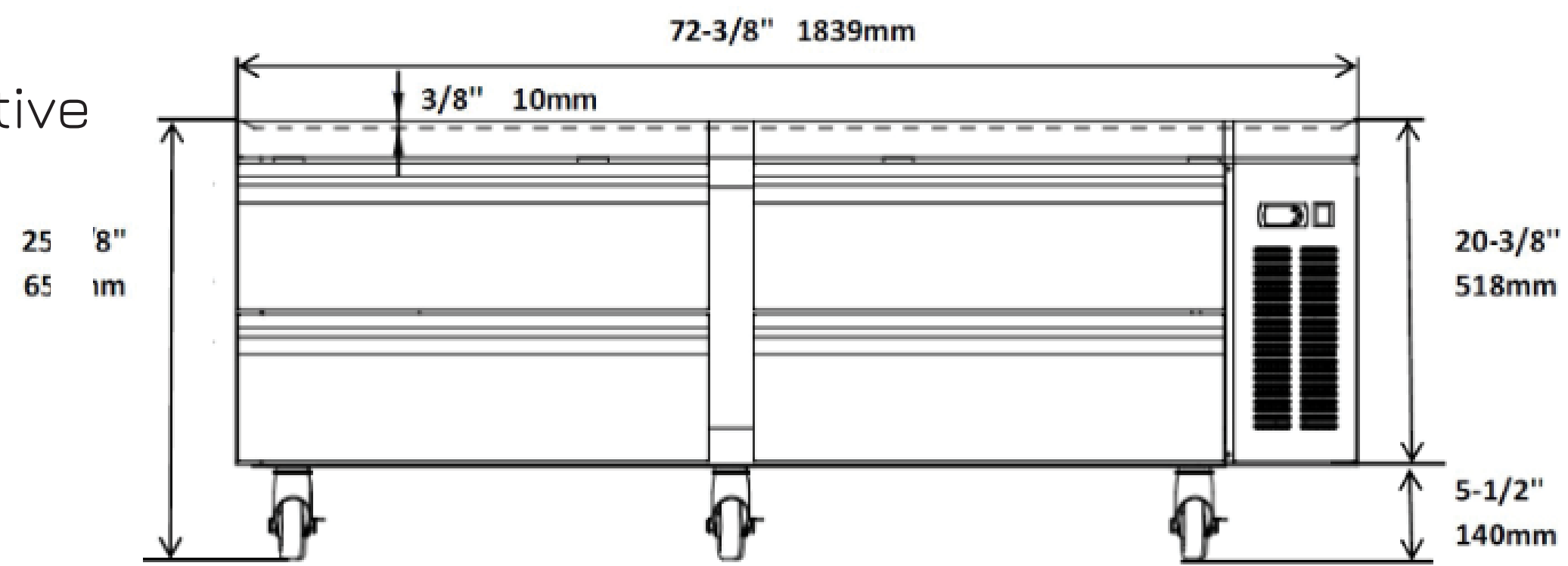

Top View

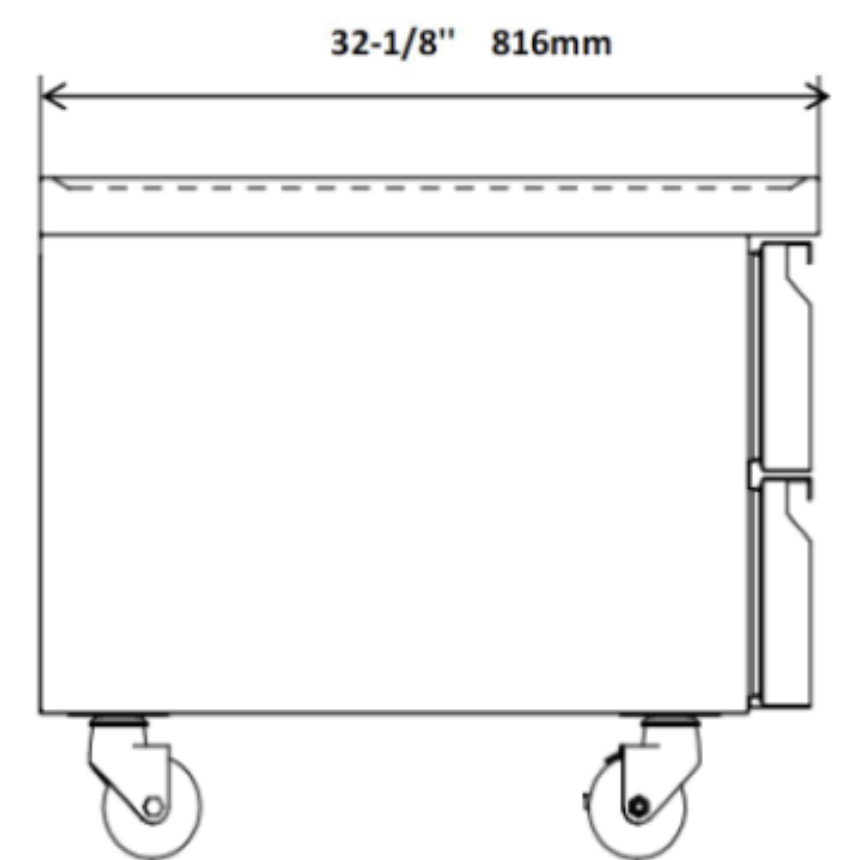

Side View