

MOTAK

Chef Base Refrigerators

Model #: **MCBR60DX**

Product Details

- Drawers with Heavy-duty sliders.
- Uses R290 refrigerant, which is eco-friendly and more efficient.
- Easy to access condenser coil for cleaning and service.
- Heavy-duty swivel casters are pre-installed.
- Electronic control system makes it easy to adjust temperature set point and defrost frequency.
- Refrigeration system keeps food at safe temperatures between 33°F and 41°F.
- Stainless steel top equipped with a marine edge enables the unit's top to contain drips and spills for easy cleanup.
- Stainless steel interior and exterior retains attractive finish longer. Matching aluminum finished back.

Not suitable for installation in non-commercial or residential applications.

Warranty

WARRANTY: Drawers 1 year parts & labor, 2 year parts & labor warranty on the refrigeration system, and additional 3 years on compressor.

Certifications

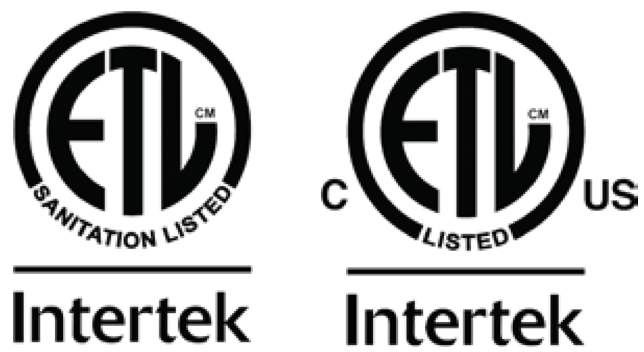

Plan View

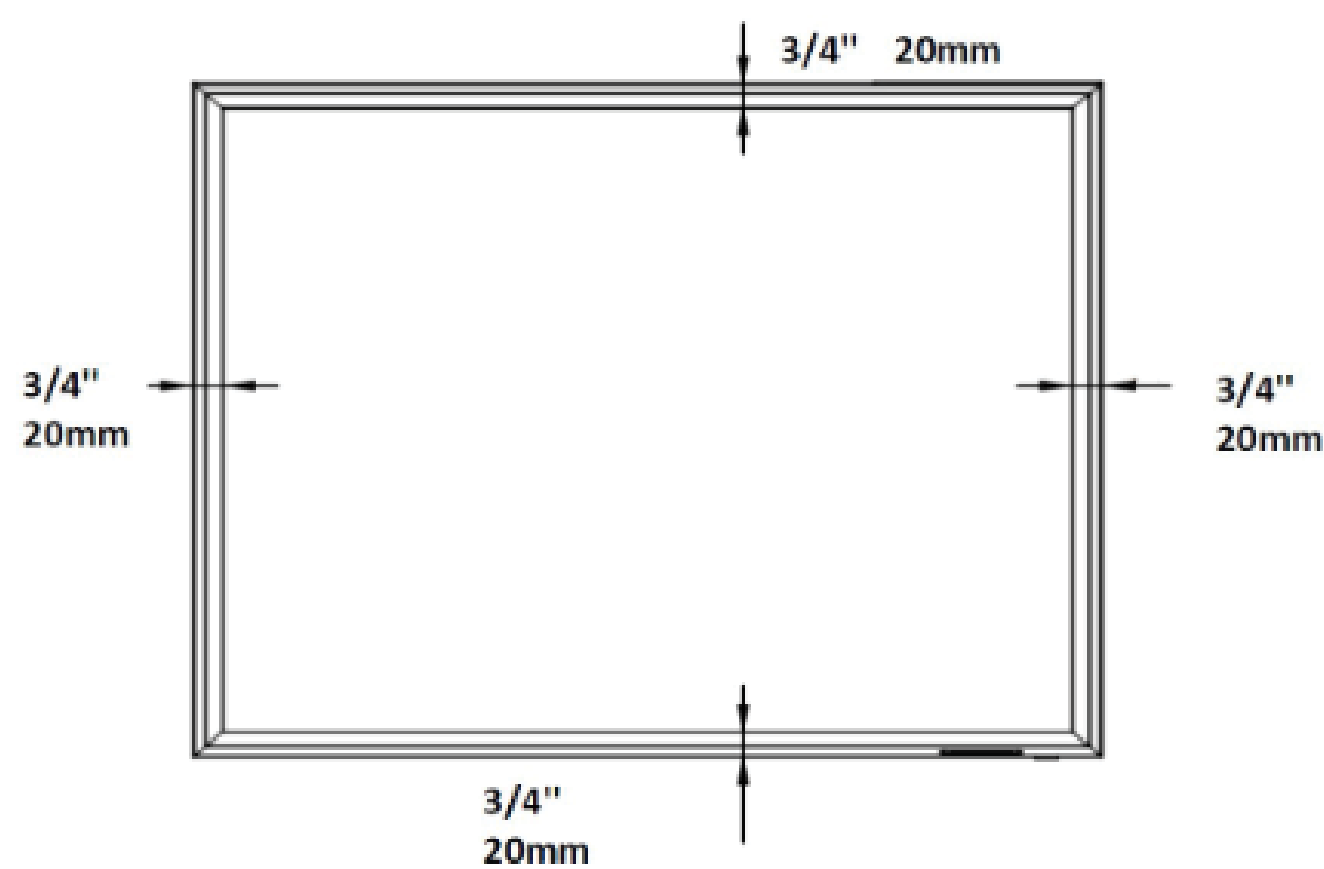
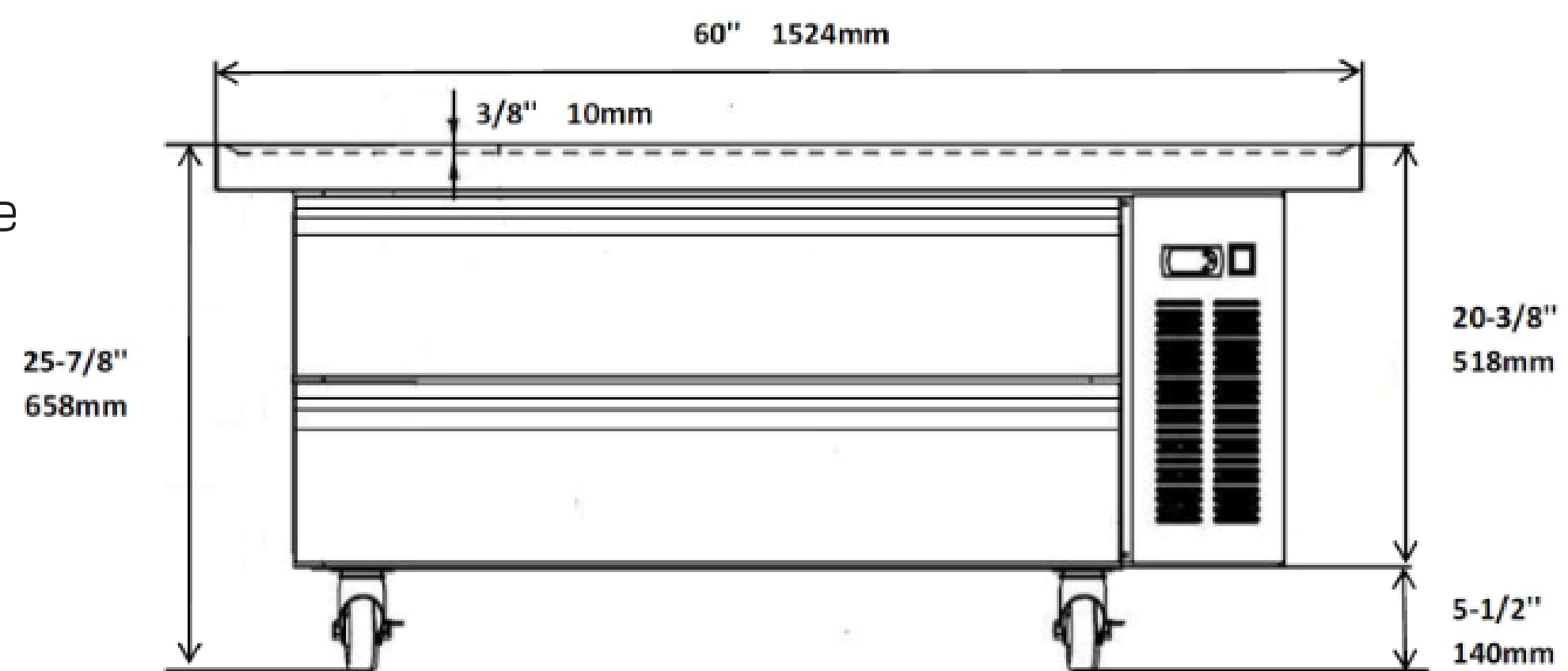

Top View

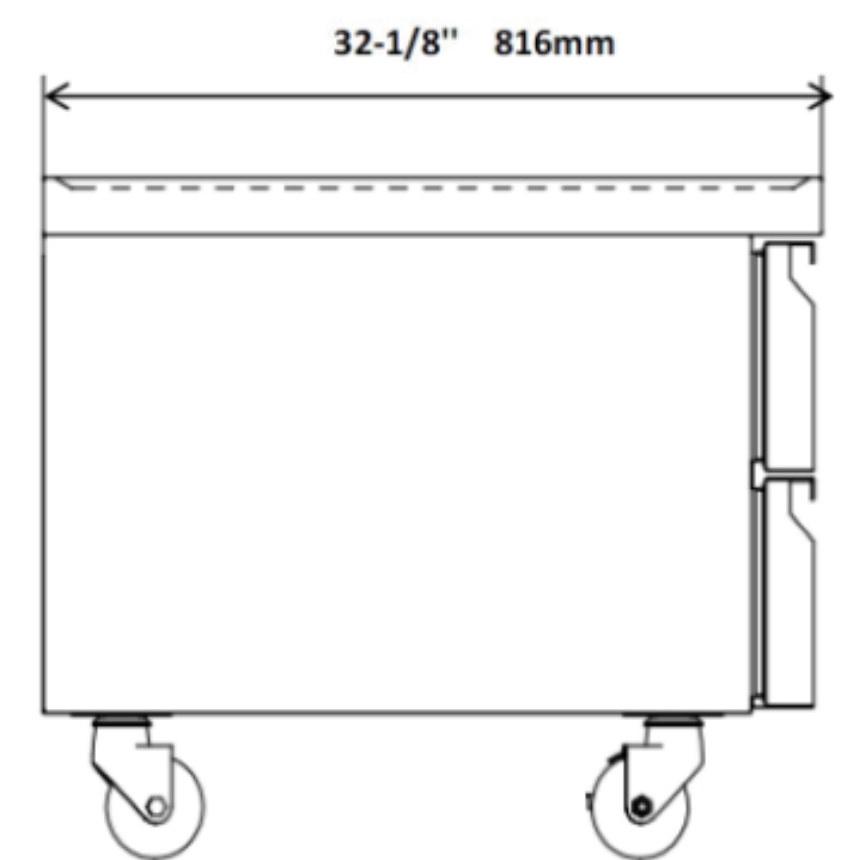

Side View

Specifications

Model	Drawers	GN Pans	Cabinet Dims (in)			HP	Voltage	Amp	NEMA Plug	Cord Length (ft)	Ship Weight
			Width	Depth	Height						
MCBR60DX	2	6*1/1+6*1/6	60"	32.125"	25.875"	1/6	115/60/1	5	5-15P	10 ft.	365

MOTAK reserves the right to make changes to the design or specifications without prior notice.