

MOTAK

Bottle Cooler

Model #: **MBST-36-X**

Product Details

- Eco friendly R290 refrigerant
- Removable bottle opener and cap catcher
- Durable stainless steel top
- Corrosion-resistant, black vinyl-covered steel exterior
- Coated aluminum interior
- Electronic control system makes it easy to adjust temperature set point and defrost frequency
- Temperature range: 33° - 38°F
- Condenser coil is easy to access for cleaning and service
- Factory-installed 3" swivel casters

Not suitable for installation in non-commercial or residential applications.



Warranty

2 years parts & labor and additional 3 years on compressor

Certifications



Specifications

Model	Doors	Dividers	12 oz. Bottles (cases)	12 oz. Cans (cases)	Cabinet Dims (in)			HP	Voltage	Amp	NEMA Plug	Cord Length (ft)	Ship Weight (lbs)
					Width	Depth	Height						
MBST-36-X	1	2	11	14.5	36"	28.125"	37.25"	1/6	115/60/1	2.28	5-15P	10 ft.	198 lbs.

Plan View

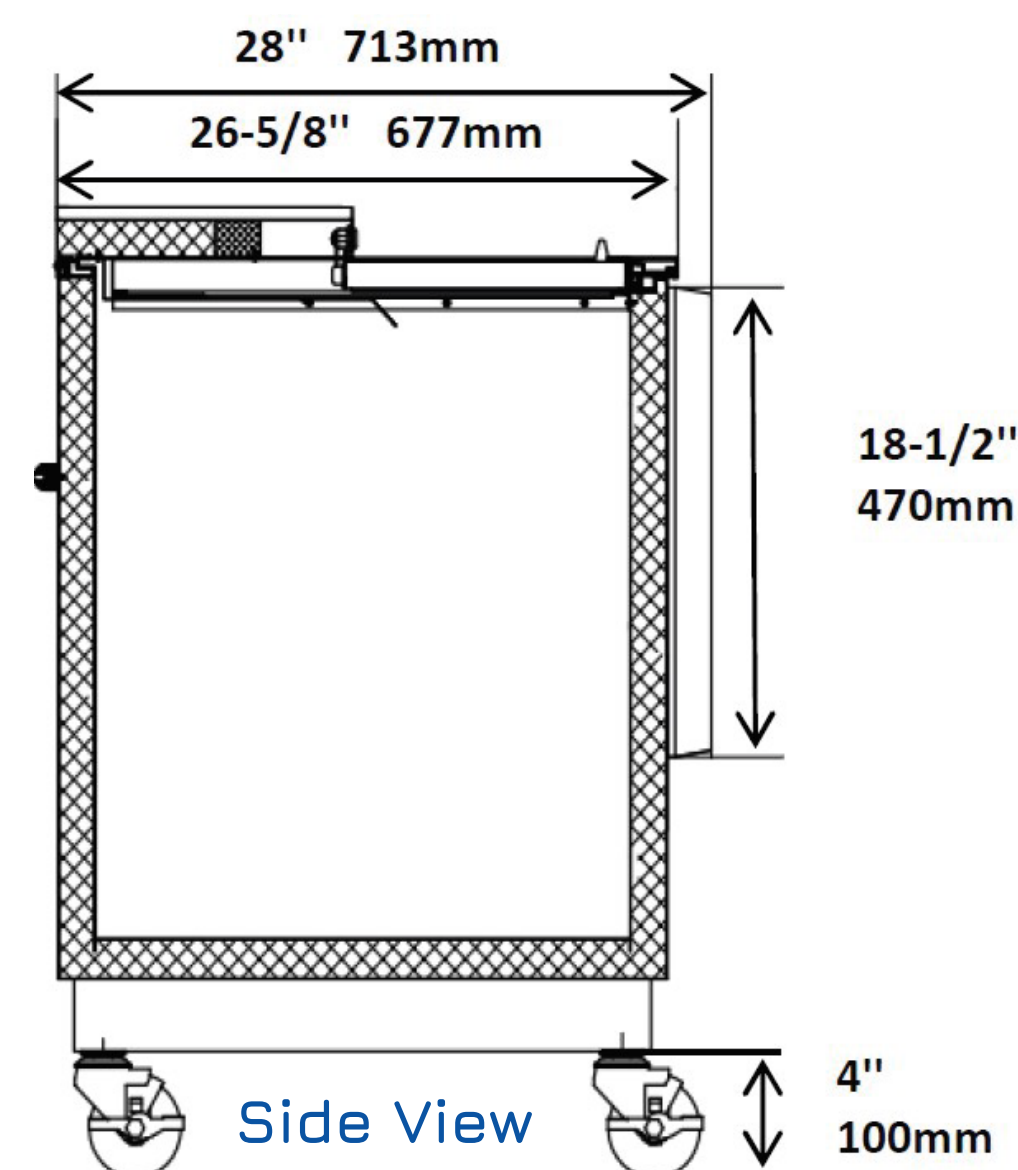
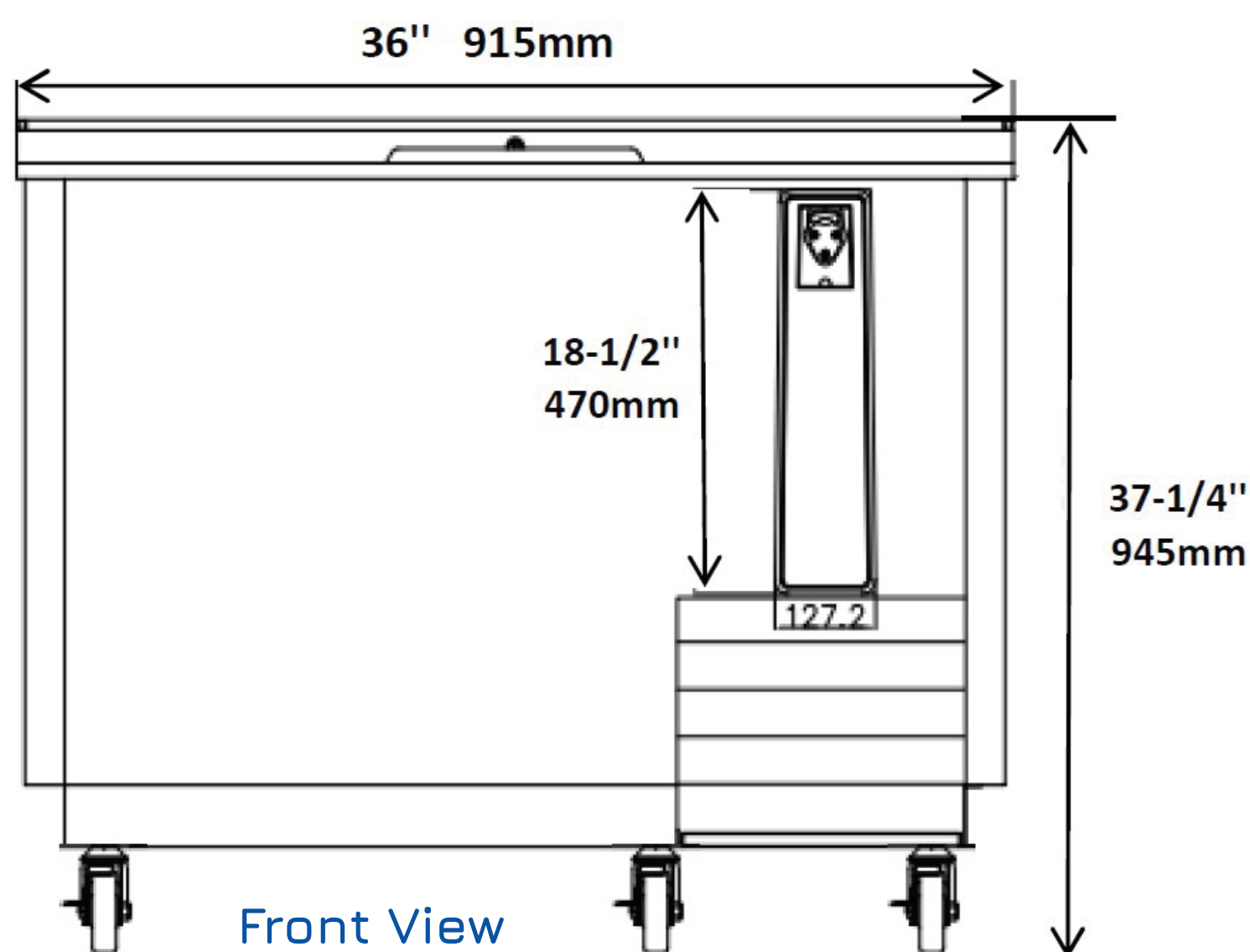

MOTAK reserves the right to make changes to the design or specifications without prior notice.

JAN0621