

MOTAK

Countertop Steamer

Model #: FSSH1800

Product Details

- Exterior is constructed of heavy duty stainless steel
- Powder coated top
- Cast aluminum well
- Water reservoir holds up to 3 quarts of water
- Simple one push button that blasts steam in excess of 212°F that rejuvenates and heats up cold, pre-cooked food inside the well.
- Illuminated On/Off rocker switch located on the front of the unit lets you know when the unit is in operation.
- Pre-heat in only 30 minutes.
- 4' power cord with NEMA 5-15 plug
- Includes half size perforated food pan
- Bakelite handle that is cool to touch
- Non-slip rubber feet for stability

Not suitable for installation in non-commercial or residential applications.

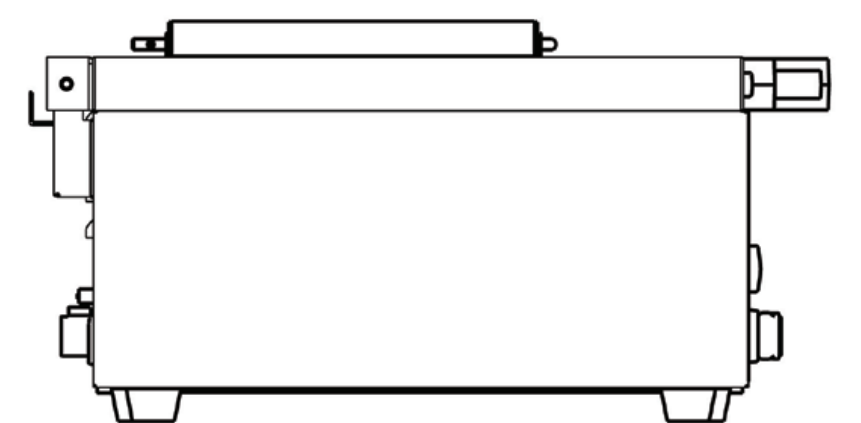
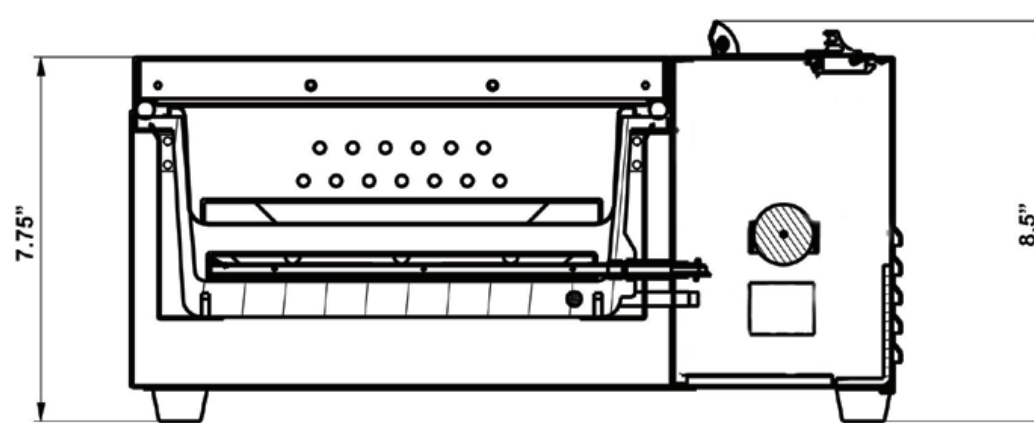
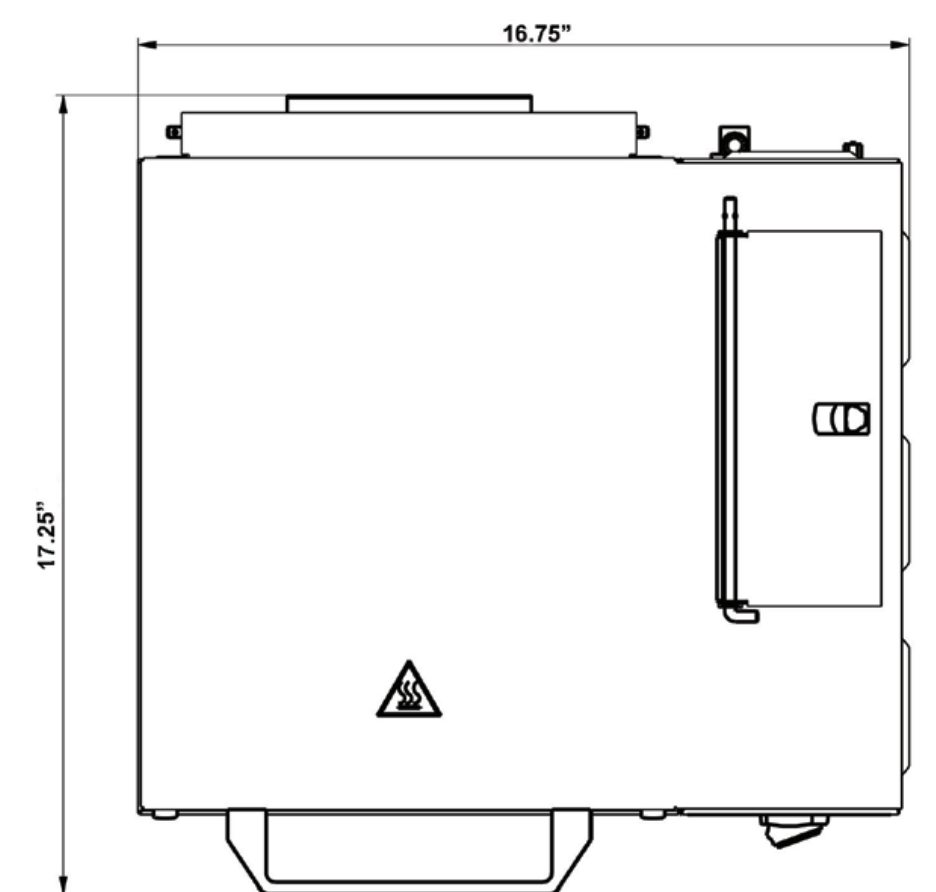

Specifications

Model	Steamer Dims (in)			Voltage	Watts	Amps	Plug
	W	D	H				
FSSH1800	16.75"	17.25"	8.5"	120V	1800W	15	NEMA 5-15P