



ITB/ITCB/HV ICB SH/DV/TWIN New Infusion Series® Platinum Edition®



SERVICE MANUAL INSTALLATION & OPERATING GUIDE

BUNN-O-MATIC CORPORATION

POST OFFICE BOX 3227
SPRINGFIELD, ILLINOIS 62708-3227
PHONE: (217) 529-6601 FAX: (217) 529-6644
www.bunn.com

To ensure you have the latest revision of the Operating Manual, Illustrated Parts Catalog, Programming Manual, or Service Manual, please visit the Bunn-O-Matic website, at www.bunn.com. This is absolutely FREE, and the quickest way to obtain the latest catalog and manual updates. For Technical Service, contact Bunn-O-Matic Corporation at 1-800-286-6070.

BUNN-O-MATIC COMMERCIAL PRODUCT WARRANTY

Commercial Warranty

Warranty statements and information can be found on our website. Please visit commercial.bunn.com/support/warranty-lookup for further details.

CONTENTS

Warranty	2
Contents.....	3
Troubleshooting	4
Diagnostic Displays.....	9
Access	10
Control Board.....	11
Membrane Switch	13
Bypass Valves	14
Brew Valves	15
Refill Valves	16
Tank Heaters	17
Limit Thermostat.....	18
Temperature Probe.....	19
DV Selector Switch	21
Power Switch.....	22
Heater Triac.....	23
SoftHeat Power	25
Transformer	26
Troubleshoot Soft Heat Feature At Brewer	27
Touch Screen (PE)	29
Wave Brew Dispense Valve (PE)	30
Air Pump (PE).....	31
Air Pump Check Valve (PE).....	32
Brew Funnel Sensing Coil	33
Funnel Lock Solenoid.....	34
I/O Board (PE).....	35
BUNNLink Board	36
Liquid Level Probe	42
Liquid Level Probe Diagnostic A/D#	43
Liquid Level Probe/Refill Calibration	44
Touch Screen Calibration	45
Error/Warning Message (PE)	46
Importance Calibrating Brew Flow Rates	49
Water Flow Calibration Menus (PE).....	50
Water Flow Calibration Steps (PE)	51
Schematic Wiring Diagrams.....	52-76

TROUBLESHOOTING

A troubleshooting guide is provided to suggest probable causes and remedies for the most likely problems encountered. If the problem remains after exhausting the troubleshooting steps, contact the Bunn-O-Matic Technical Service Department.

- Inspection, testing, and repair of electrical equipment should be performed only by qualified service personnel.
- All electronic components have ac line voltage and some have low voltage dc potential on their terminals. Shorting of terminals or the application of external voltages may result in board failure.
- Intermittent operation of electronic circuit boards is unlikely. Board failure will normally be permanent. If an intermittent condition is encountered, the cause will likely be a switch contact or a loose connection at a terminal or crimp.
- Solenoid removal requires interrupting the water supply to the valve. Damage may result if solenoids are energized for more than ten minutes without a supply of water.
- The use of two wrenches is recommended whenever plumbing fittings are tightened or loosened. This will help to avoid twists and kinks in the tubing.
- Make certain that all plumbing connections are sealed and electrical connections tight and isolated.
- This brewer is heated at all times. Keep away from combustibles.

WARNING

- **Exercise extreme caution when servicing electrical equipment.**
- **Unplug the brewer when servicing, except when electrical tests are specified.**
- **Follow recommended service procedures.**
- **Replace all protective shields or safety notices.**

Before troubleshooting this brewer, check for the following:

Control Boards

1. Make sure ribbon cable is properly attached to the control board (ALL PINS INSERTED INTO PLUG).
2. Make sure before servicing brewer that voltage is present at control board.
3. Press any warmer switch or observe if any indicator lights are glowing on the control panel. If so, proceed with testing. If not, check for voltage across pins 9 & 11 of the 14 pin connector (black and white wires). If voltage is present, replace the control board. If voltage is not present, check wiring and voltage across terminal block (black and white). Correct the problem and retest before proceeding with testing.

NOTE: In the event of board replacement, technician will need to re-program customer's settings and/or recipes, as well as re-calibrate the temperature probe in program level 2 and re-enter the serial number in level 2.

TROUBLESHOOTING (cont.)

REFILL CIRCUIT

PROBLEM

PROBABLE CAUSE

REMEDY

Will not refill

1. Power off to brewer

Press ENABLE BREW switch on control panel to determine if power is ON.

2. Water shut off

Make sure water is ON.

3. Error Message

Brewer has shut down due to malfunction (See Diagnostic Section in this manual).

4. ON/OFF Switch
(If equipped)

Make sure ON/OFF Switch is "ON" and indicator is lit.

5. Lime build up on Probe(s)

Remove the Level Probe(s) and check for lime deposit on tip. Clean and reinstall.

6. Refill Valve or Control Board

Check valve.

Refill does not shut off
Power "ON"

1. Lime build up on probe

Remove Level Probe and check for lime deposits on tip. Clean and reinstall.

2. Water Level Sensing System

Replace control board

3. Refill valve or control board

Check valve.

Refill does not shut off
Power "OFF"

1. Refill valve

Clean or replace valve as needed.

TROUBLESHOOTING (cont.)

HEATING CIRCUIT

PROBLEM

Water does not heat to proper temperature

IMPORTANT: Make sure no temperature tests are taken before the display reads ready. Tank temperature must be stabilized before readings are taken.

Spitting or excessive steaming (cont.)

Brewer is making unusual noises

PROBABLE CAUSE

1. Display's error message
2. Water not touching main (short) level probe
3. Water Level Probe Sensing System
4. Temperature Probe
5. Limit Thermostat or TCO
6. Tank Heater
7. Off Board Triac

1. Lime build up on temperature probe, tank or tank heater
2. Temperature Probe
3. Control Board

1. Plumbing lines
2. Water supply
3. Lime build up

REMEDY

Brewer has shut down due to malfunction. See Diagnostics.

Remove level probe and grommet. Look into hole on tank lid. Water must be within approximately one inch from top of tank.

Check refill circuit. Heaters will not turn on if water is not grounding level probe.

Check/replace

Check/replace

Check/replace

Check/replace

Inspect probe and tank assembly for excessive lime deposits. Delime as required.

Check/replace

Check/replace

Plumbing lines should not rest on the counter top.

The brewer must be connected to a cold water supply.

Remove the tank lid and clean inside of tank with a deliming agent, if necessary.

TROUBLESHOOTING (cont.)
BREWING CIRCUIT

PROBLEM

Brew cycle will not start

PROBABLE CAUSE

1. Display's error message
2. No water
3. No power or incorrect voltage to the brewer
4. ON/OFF switch not in the "ON" position
5. Low water temperature (Brew lockout is enabled)
6. Water not touching refill probe inside tank
7. Membrane Switch
8. Dispense valve
9. Control board

REMEDY

- Brewer has shut down due to malfunction. See Diagnostics.
- Water lines and valves to the brewer must be open.
- Check for voltage across the terminals at the terminal block.
- The indicator lamp must be lit
- Allow brewer to heat until ready, or disable the brew lockout feature.
- Water must be in contact with refill probe before brew cycle will start.
- Check/replace
- Check/replace
- Check/replace

Consistently low beverage level in the dispenser or beverage overflows dispenser

1. Brew volume
NOTE: Volume adjustments must be made with sprayhead installed.
2. Lime build up
3. Dispense Valve

- Inspect the dispense valve and sprayhead for excessive lime deposits. Delime as required.
- Remove dispense valve and clear any obstructions. Rebuild or replace valve if necessary. (See page 15)
- Check/replace

TROUBLESHOOTING (cont.)

BREWING CIRCUIT (cont.)

<u>PROBLEM</u>	<u>PROBABLE CAUSE</u>	<u>REMEDY</u>
Dripping from sprayhead	1. Lime build up	Inspect the tank assembly for excessive lime deposits. Delime as required.
	2. Dispense valve	Check/replace
Weak beverage	1. Sprayhead	A clean sprayhead must be used for proper extraction.
	2. Water temperature	Place an empty brew funnel on an empty decanter beneath the sprayhead. Initiate brew cycle and check the water temperature immediately below the sprayhead with a thermometer. The reading must not be less than 195°F (91°C). Adjust the temperature setting to increase the water temperature. Refer to Initial Set-up instructions.
	3. Filter type	BUNN® paper filters must be used for proper extraction.
	4. Coffee grind	A fine drip or grind must be used for proper extraction.
	5. Funnel loading	The BUNN® paper filter must be centered in the funnel and the bed of grounds leveled by shaking gently.
Dry coffee grounds remain in the funnel	1. Sprayhead	Make sure sprayhead is present and holes are clear and unobstructed.
	2. Funnel loading	The BUNN® paper filter must be centered in the funnel and the bed of grounds leveled by shaking gently.
Low beverage serving temperature		Preheat server
	1. Thermal server/airpot not pre-heated before brew cycle	

DIAGNOSTICS

MESSAGE	PROBABLE CAUSE	REMEDY
Temperature Too Low	1. Water temperature in the tank does not meet the ready temperature.	A) Wait for the brewer to heat to the proper temperature. B) Disable the BREW LOCKOUT function. Refer to programming section for procedure.
Heating Time Too Long	1. Tank Heater failure. 2. Control Board/Thermistor failure	Replace or repair as needed Replace or repair as needed
Fill Time Too Long	1. Water shut off to brewer 2. Supply line too small or obstructed 3. Inlet Solenoid failure 4. Control Board Failure 5. ON/OFF switch is OFF	Check water supply shut-off Replace or repair as needed Replace or repair as needed Replace or repair as needed Turn switch ON
Temp Sensor Out Of Range, Check For Bad Connections	1. Temperature Sensor Probe open	Replace or repair as needed
Temp Sensor Out Of Range, Check Wire For Shorts	1. Temperature Sensor Probe wire(s) shorted	Replace or repair as needed

COMPONENT ACCESS

This section provides procedures for testing and replacing various major components used in this brewer should service become necessary. Refer to Troubleshooting for assistance in determining the cause of any problem.

WARNING - Inspection, testing, and repair of electrical equipment should be performed only by qualified service personnel. The brewer should be unplugged when servicing, except when electrical tests are required and the test procedure specifically states to plug in the brewer.

WARNING - Disconnect the brewer from the power source before the removal of any panel or the replacement of any component.

All components are accessible by the removal of the top cover or front access panel.

Refer to wiring diagrams at the back of this manual when reconnecting wires.



FIG. 10-2 ITB/ITCB COMPONENT ACCESS



FIG. 10-1 ICB/ITCB HV COMPONENT ACCESS



FIG. 10-3 ICB/ITCB HV TWIN COMPONENT ACCESS

CONTROL BOARD

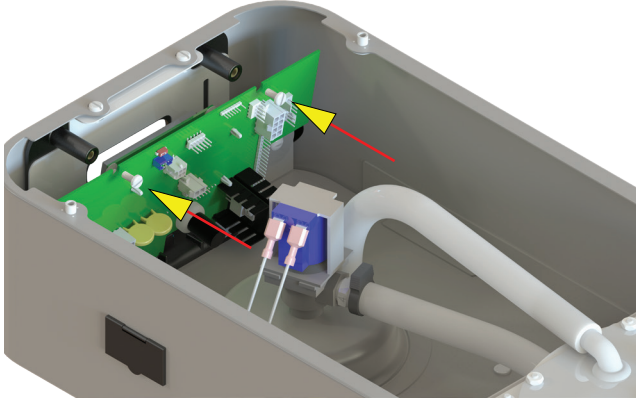

FIG. 11-1 CONTROL BOARD

Location:

The Control Board is located inside the top cover behind the front face plate.

Test Procedures:

The test procedures for the control board will vary depending upon the problems experienced by the brewer. Refer to the Troubleshooting section which is divided into three sections, Refill Circuit, Heating Circuit, and Brewing Circuit.

Check for Power to board:

1. Insert one meter lead in J17-pin 9 and the other lead in J17-pin 11.
2. With the power connected to brewer, the voltage reading to the board should be the line voltage rated for that model.

If no voltage is present, check wiring to the board. If voltage is present, and brewer does not power on, go to step 3

3. Check for line voltage at J15-1 BLK to J15-2 WHI.

If no voltage is present, replace the control board. If voltage is present, go to step 4

4. Check for 12VAC at J15-4 to J15-2 Yellow wires.

If no voltage is present, replace the transformer. If voltage is present, and brewer does not power on, replace the control board.

Removal and Replacement:

1. Disconnect brewer from power source.
2. Disconnect the wires from the relay on the control board.
3. Disconnect all of the connectors from the control board.
4. Remove the two screws securing the control board to the faceplate.
5. Tilt the control board inward to clear the display section.
6. Place the bottom edge of the new control board in the cradle, tilt the board forward, and secure with the two nuts to the hood.
7. Re-install connectors.

Faceplate Removal and Replacement:

1. Disconnect brewer from power source.
2. Disconnect the ribbon cable from the control board.
3. **Models with faucet:** Drain tank to below faucet outlet fitting. Remove hose, nut and washer from faucet. Remove faucet assembly.
4. Remove the two screws and two nuts securing the face plate to the hood.
5. Carefully pull the ribbon cable through the front opening of the hood.
6. Installation is the reverse order.

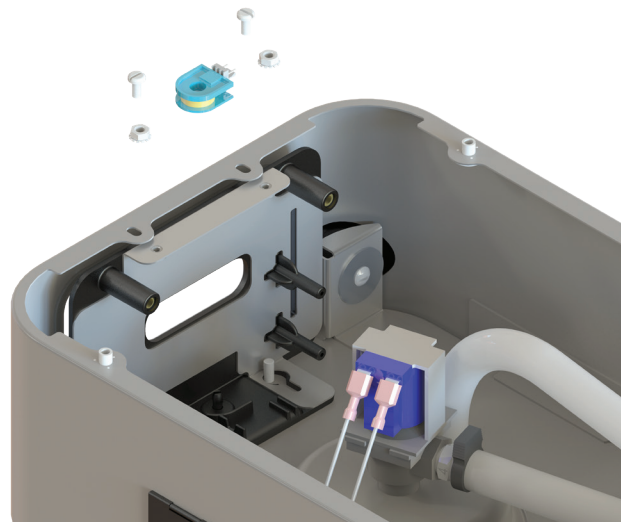

FIG. 11-2 FACEPLATE REMOVAL

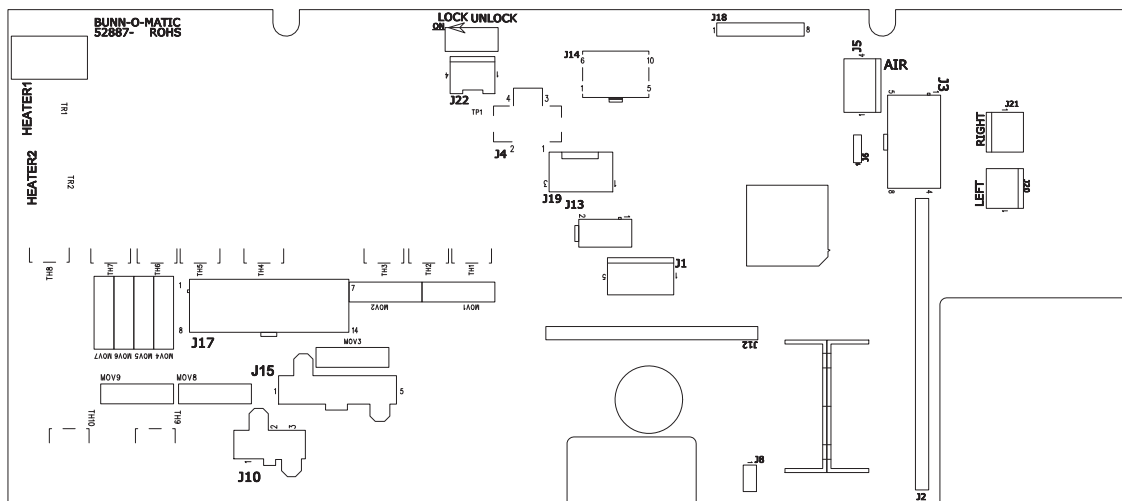

FIG. 12 TRIAC MAP

CONTROL BOARD-ICB TWIN/ITCB DV HV/ITCB TWIN HV TRIAC MAP

Triac:	Load Component:	Connector:
TH1/MOV3/BR2	Left Funnel Lock	J17-13/J17-14
TH2/MOV1	Refill solenoid	J17-5
TH3/MOV2/BR3	Right Funnel Lock	J17-6/J17-7
OFFBOARD	Tank Heaters	TR1/TR2
TH4/MOV6	Left Brew Solenoid	J17-3
TH5/MOV4	Right Brew Solenoid	J17-2
TH6/MOV5	Left Bypass Solenoid	J17-1
TH7/MOV7	Right Bypass Solenoid	J17-10

CONTROL BOARD-ICB/ITCB TRIAC MAP

Triac:	Load Component:	Connector:
TH1/MOV3/BR2	Funnel Lock	J17-13/J17-14
TH2/MOV1	Refill solenoid	J17-5
TH4/MOV6	Brew Solenoid	J17-3
OFFBOARD	Tank Heater(s)	TR1
TH6/MOV5	Dilution or Bypass Solenoid	J17-1

CONTROL BOARD-ITB TRIAC MAP

Triac:	Load Component:	Connector:
TH6/MOV5	Main or Left Dilution	J17-1
TH2/MOV1	Refill solenoid	J17-5
TH4/MOV6	Brew Solenoid	J17-3
TH7/MOV7	Right Dilution	J17-10
TH9/MOV8	Sweetner	J10-3
OFFBOARD	Tank Heater	TR1
TH1/MOV3/BR2	Funnel Lock	J17-13/J17-14

MEMBRANE SWITCH

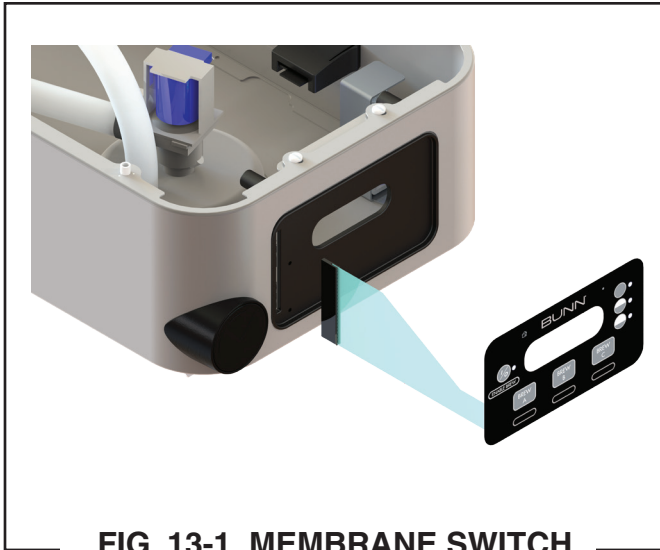

FIG. 13-1 MEMBRANE SWITCH

Location:

The Membrane Switch is located on the front face plate.

Test Procedures:

There are two methods for testing the membrane switch. The easiest method is to use the built in test mode. Refer to the Programming Section for Service Tools/Test Switches. If for some reason you can't get into the program modes, or brewer won't power up, you can test it with an ohmmeter or continuity tester. Refer to the schematic to trace the appropriate pins.

NOTE: Pin 22 is the static shield & will not provide a reading to the other pins. There are two commons in this circuit, pins 9 & 10. Disconnect brewer from power source before disconnecting ribbon cable from control board.

Removal and Replacement:

1. Disconnect the ribbon cable from the 22-pin connector on the control board.
2. Gently peel the membrane switch from the front face plate assembly.
4. Remove any adhesive that remains on the front face plate.
5. Remove the adhesive backing from the new membrane switch. Insert the ribbon cable through the slot in the front face plate and apply the membrane switch to the front face plate.
6. Connect the ribbon cable to the 22-pin connector on the control board making sure every pin on the control board is inserted into the ribbon cable connector.

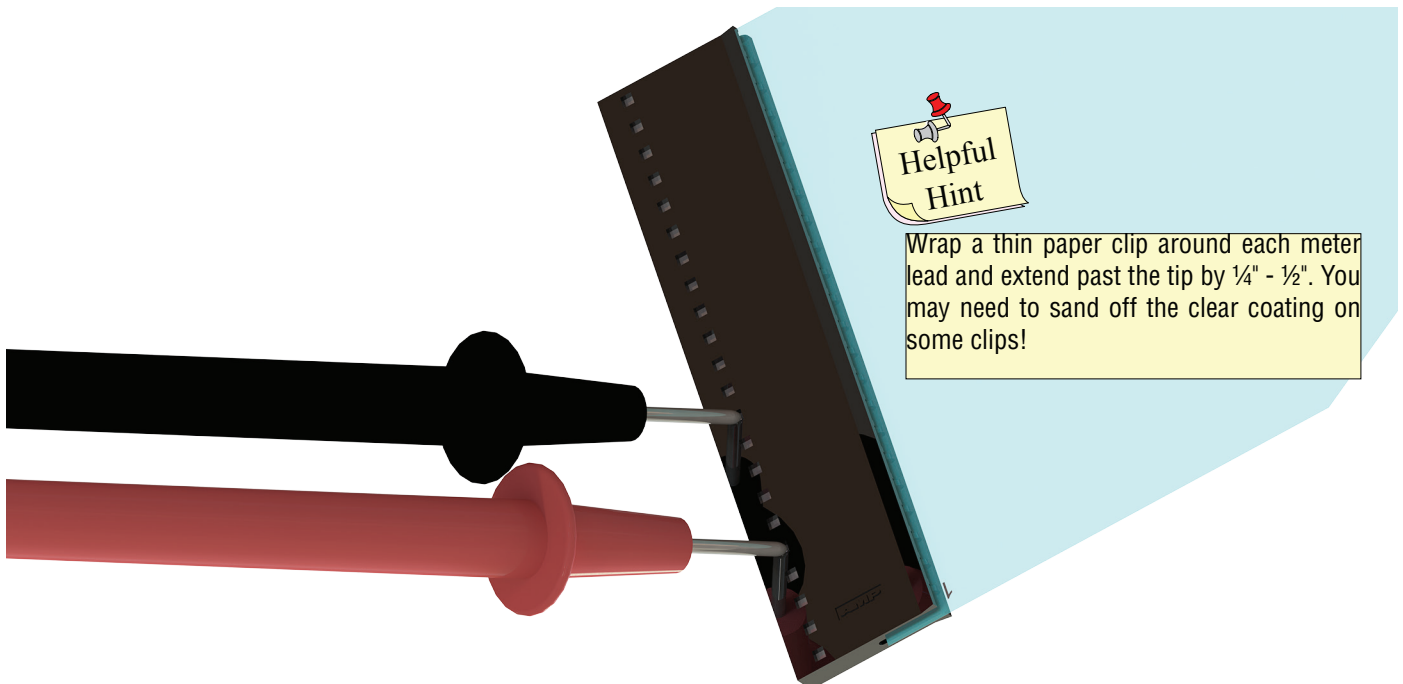

FIG. 13-2 MEMBRANE SWITCH CONTINUITY

BYPASS VALVE ON ALL ICB's

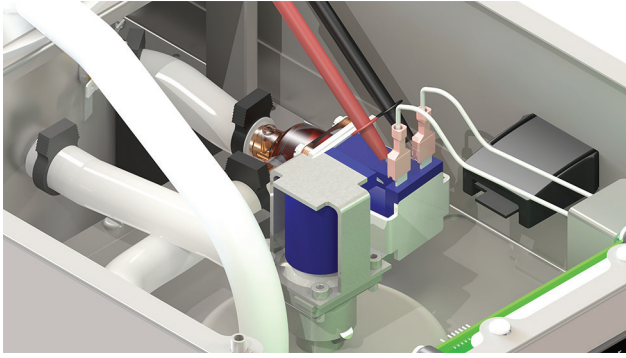

FIG. 14-1 BYPASS VALVE

Location:

The bypass valve is located inside the top cover behind the front face plate.

Test Procedures:

1. Refer to the Programming Section for Service Tools/ Test Outputs/Bypass Valve.
2. Be sure brew funnel & server are in place before activating valve.
3. Check the valve for coil action. Turn on the valve with the test mode. Listen carefully in the vicinity of the brew valve for a click as the coil pulls the plunger in.

If no sound is heard as described, proceed to #4. If the sound is heard as described, there may be a blockage in the valve, hose, tank, or sprayhead. Disconnect the brewer from the power source. Remove the valve and inspect for blockage, and de-lime all related areas.

4. Connect the voltmeter leads to the coil terminals. Turn on the valve with the test mode. The indication will be 2-3VAC off, 120VAC on. Set the meter to DC volts. The indication should be 150-160VDC when off, 0V when on. If the polarity of meter leads are reversed, reading will indicate -150-160VDC. **(Double these readings for 240 volt coils)**

If voltage is present as described, but no coil action is

observed, brew valve is defective. Replace valve and test again to verify repair.

If voltage is not present as described, refer to Wiring Diagrams and check the brewer wiring harness. Also check the control board and switch for proper operation.

Removal and Replacement:

1. Disconnect the brewer from the power source.
2. Disconnect wires from the valve.
3. Drain enough water from the tank so the water level is below the outlet.
4. Remove hoses from the valve.
5. Remove the two #8-32 nuts securing the valve to the sprayhead panel.
6. Install new valve using the two #8-32 nuts.
7. Reconnect hoses to the valve and secure in place with clamps.

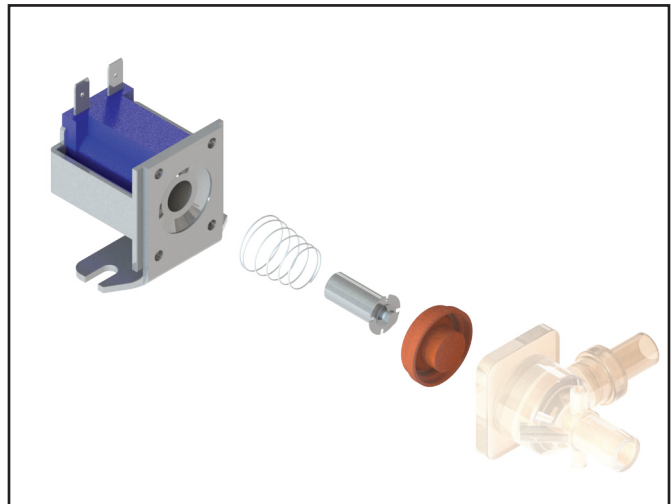

FIG. 14-2 EXPLODED VIEW



Due to the internally rectified coil, do not attempt to test this type of coil with an ohm-meter. The reading will be open or very high resistance, depending on the polarity of your meter leads.

BREW VALVE

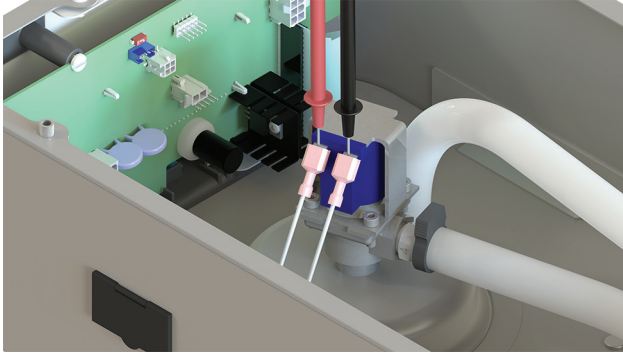

FIG. 15-1 BREW VALVE

Location:

The brew valve is located inside the top cover behind the front face plate.

Test Procedures:

1. Refer to the Programming Section for Service Tools/Test Outputs/Brew Valve.
2. Be sure brew funnel & server are in place before activating valve.
3. Check the valve for coil action. Turn on the valve with the test mode. Listen carefully in the vicinity of the brew valve for a click as the coil pulls the plunger in.

If no sound is heard as described, proceed to #4. If the sound is heard as described, there may be a blockage in the valve, hose, tank, or sprayhead. Disconnect the brewer from the power source. Remove the valve and inspect for blockage, and de-lime all related areas.

4. Connect the voltmeter leads to the coil terminals. Turn on the valve with the test mode.

The indication will be 2-3VAC off, 120VAC on. Set the meter to DC volts. The indication should be 150-160VDC when off, 0V when on. If the polarity of meter leads are reversed, reading will indicate -150-160VDC. **(Double these readings for 240 volt coils)**

If voltage is present as described, but no coil action is observed, valve is defective. Replace valve and test again to verify repair.

If voltage is not present as described, refer to Wiring Diagrams and check the brewer wiring harness. Also check the control board and membrane switch for proper operation.

Removal and Replacement:

1. Disconnect the brewer from the power source.
2. Disconnect wires from the valve.
3. Drain enough water from the tank so the water level is below the outlet.
4. Remove sprayhead and hose from the valve.
5. Remove the nut securing the valve to the sprayhead panel.
6. Install new valve using the nut from step 5.
7. Reinstall sprayhead and hose to the valve and secure in place with clamps.

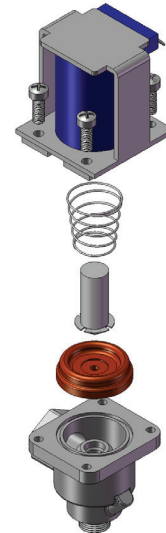

FIG. 15-2 BREW VALVE



Due to the internally rectified coil, do not attempt to test this type of coil with an ohmmeter. The reading will be open or very high resistance, depending on the polarity of your meter leads.

REFILL VALVES

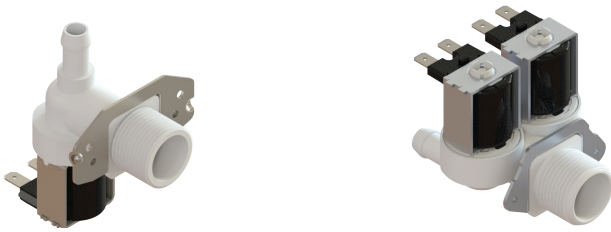

FIG. 16-1 REFILL VALVES

Location:

The refill valve is located inside the front of the brewer.

Test Procedures:

1. Enter programming level 2, scroll to "Service Tools" then scroll to "Refill Valve".

2. *Briefly* activate the refill valve in the test mode. With a voltmeter, check the voltage across the coil wires.

3. The indication must be 120 volts ac for two wire 120 volt models and three wire 120/208 -240 volt models or 230 volts ac for two wire 230 volt models.

If voltage is present, proceed to # 4.

If voltage is not present, refer to Wiring Diagrams and check main wiring harness. If harness checks ok, replace control board.

4. Check the refill valve for coil action. *Briefly* activate the refill valve in the test mode and listen carefully near the refill valve for a "clicking" sound as the magnetic coil pulls the plunger in.

If the sound is heard as described and water will not pass through the refill valve, there may be a blockage in the water line before the refill valve or, the solenoid valve may require inspection for wear, and removal of waterborne particles.

If the sound is not heard as described, proceed to # 5.

5. Disconnect the brewer from the power source. 6. Check for resistance across the coil terminals (200 Ω -2k Ω depending on which coil is being checked).

If resistance is not present as described, replace the refill valve.

If resistance is present as described, check for debris in the valve.

Removal and Replacement:

1. Remove both wires from the refill valve.
2. Verify that the white shutoff clamp between valve and tank is squeezed shut.

3. Disconnect both water lines at the valve.
4. Remove the two screws securing the valve to the component mounting bracket.
5. Using the two screws, install the new valve to the component mounting bracket.
6. Securely fasten the water lines to the valve.
7. Refer to wiring diagrams when reconnecting the wires.
8. Install access panels and covers and refer to Initial Set-up for refill and operation.

ICB & ITB

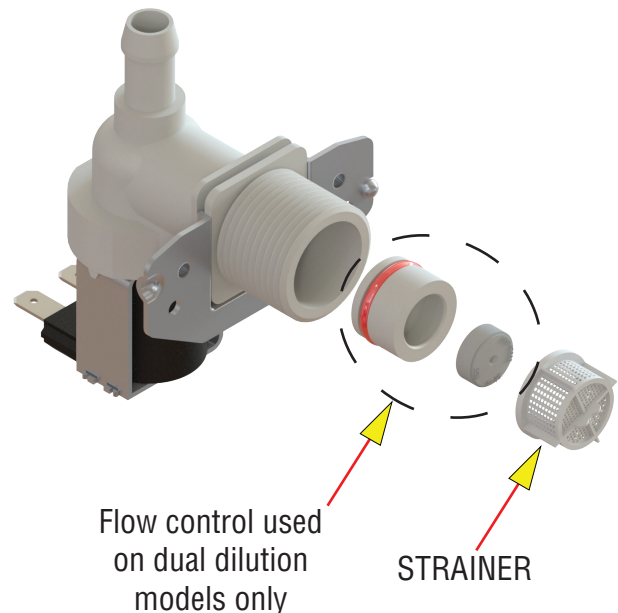

ITCB & ITB-DD



TANK HEATERS

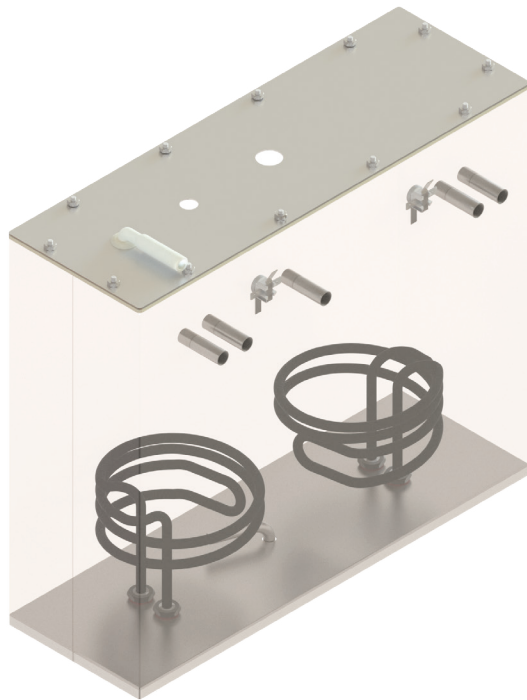

FIG. 17-1 ICB TWIN TANK HEATERS

Location:

The tank heaters are located inside the tank and secured to the tank bottom.

Test Procedures:

1. With a voltmeter, check voltage across the white wire (120V Models) or red wire (120/208-240V Models) from the terminal block and black wire from the control board. Connect brewer to the power source. The indication must be 120 volts ac for two wire 120 volt models or 208-240 volts ac for three wire 120/208-240 volt models (during a heating cycle).
2. Disconnect the brewer from the power source.

If voltage is present as described, proceed to #3.

If voltage is not present as described, refer to the Wiring Diagrams and check wiring harness.

3. Disconnect the wires from the tank heater terminals.
4. Check resistance value across tank heater terminals and compare to chart.

If resistance is present as described, reconnect the wires, the tank heater is ok.

If resistance is not present as described, replace the tank heater.

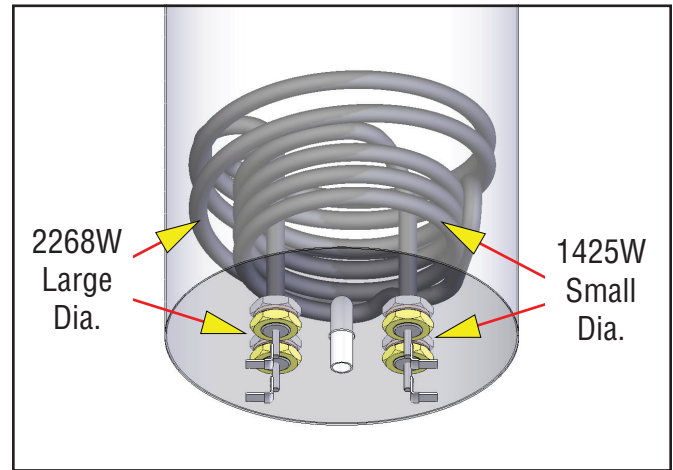

FIG. 17-2 DV TANK HEATERS

HEATER	RESISTANCE
1425W-120V	9.5-11.0 Ω
3500W-240V	15.1-17.6 Ω
1680W-120V	7.9-9.2 Ω
1800W-120V	7.4-8.7 Ω
2268W-120V	5.9-6.9 Ω
3000W-208V	12.9-15.1 Ω
3000W-240V	17.9-20.7 Ω
3500W-200V	10.5-12.2 Ω
TERMINAL TO SHEATH - INFINITE (OPEN)	

NOTE- If any resistance is read between sheath and either terminal, remove and inspect heater for cracks in the sheath.

Removal and Replacement:

1. Remove the top cover and front access panel as previously described.
2. Drain water from the tank.
3. Disconnect all the hoses from the tank.
4. Remove the temperature probe from the grommet in the tank lid.
5. Remove the level probe from it's grommet.
6. Disconnect the green wire from the tank lid.
7. Disconnect the wires from tank heater terminals.
8. Remove the nuts securing the tank lid to the tank.
9. Remove the hex nuts securing the tank heater to the bottom of the tank. Remove tank heater(s) with gaskets and discard.
10. Install new tank heater(s) with gaskets to the bottom of the tank and secure with two hex nuts.
11. Install tank lid and secure with nuts.
12. Reconnect the wires to tank heater terminals.

LIMIT THERMOSTAT

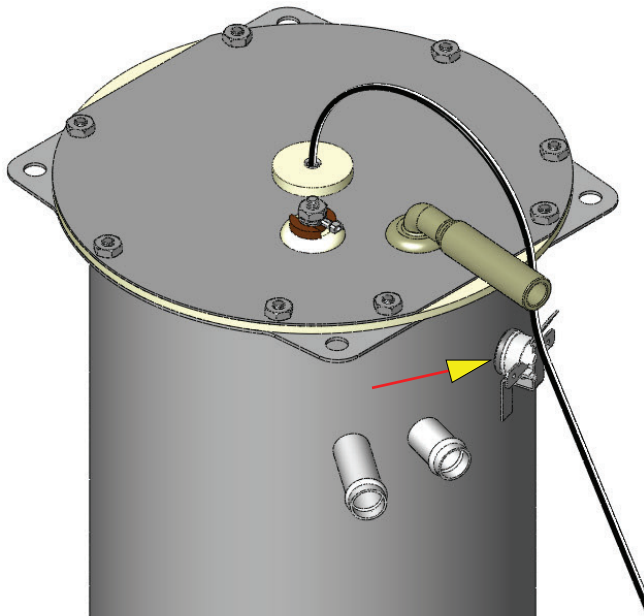

FIG. 18-1 LIMIT THERMOSTAT

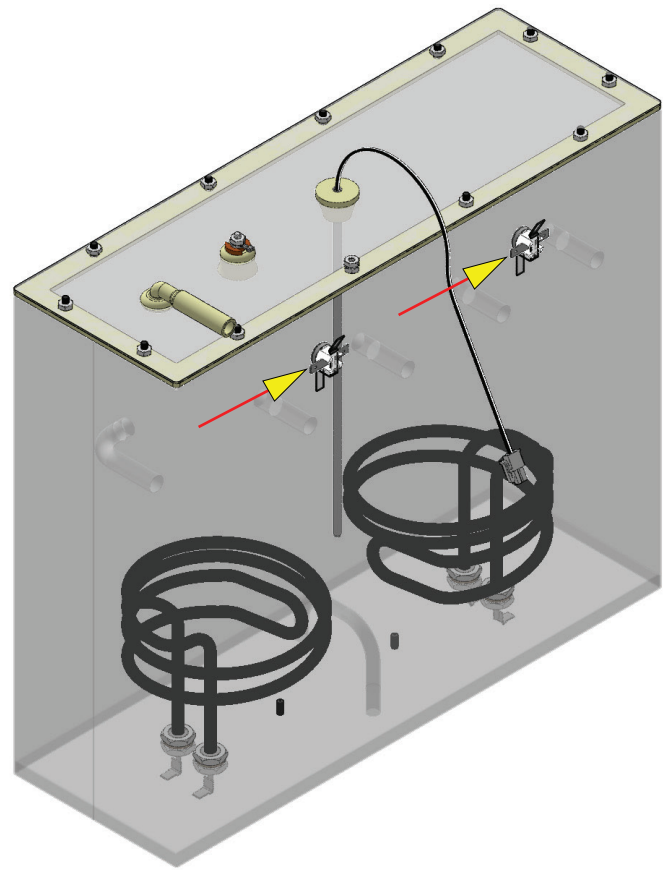

FIG. 18-2 LIMIT THERMOSTATS

Location:

The limit thermostat is located on the tank lid (on the front of the tank on twins).

Test Procedures:

1. Disconnect the brewer from the power source and allow to cool.
2. Disconnect the wires from the limit thermostat.
3. With an ohmmeter, check for continuity across the limit thermostat terminals.

If continuity is present as described, the limit thermostat is operating properly.

If continuity is not present as described, replace the limit thermostat.

Removal and Replacement:

1. Remove the wires from limit thermostat terminals.
2. Carefully slide the limit thermostat out from under the retaining clip and remove limit thermostat.
3. Carefully slide the new limit thermostat into the retaining clip. Ensure the metal face has good contact with tank.

TEMPERATURE PROBE

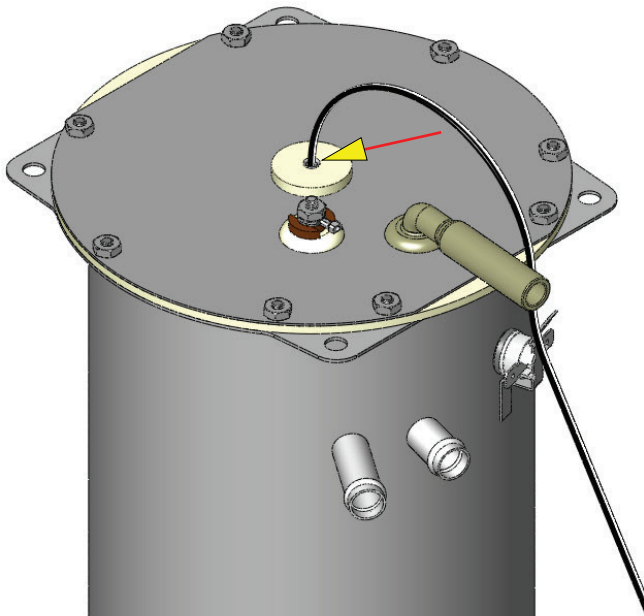

FIG. 19-1 TEMPERATURE PROBE

Location:

The temperature probe is inserted through the tank lid assembly.

Test Procedures:

1. Disconnect the brewer from the power source.
2. With a DC voltmeter, check voltage across the two wires at J13 (J3 on ITB) on control board (black probe to black wire, red probe to white wire refer to FIG 19-2). Connect the brewer to the power source. The indication should be between 4vdc (cool) to 1vdc at ready temperature.
3. Disconnect the brewer from the power source.

If voltage is present as described, circuit is working correctly.

If voltage is not present as described, proceed to #4.

4. Disconnect temperature probe from J9 on control board. Check the resistance across the two terminals of the temperature probe. The indication should be between 10.5K Ω cool to 870 Ω at ready temperature.

If resistance is to specification, replace the control board.

If resistance is not to specification, replace the temperature probe.

Removal and Replacement:

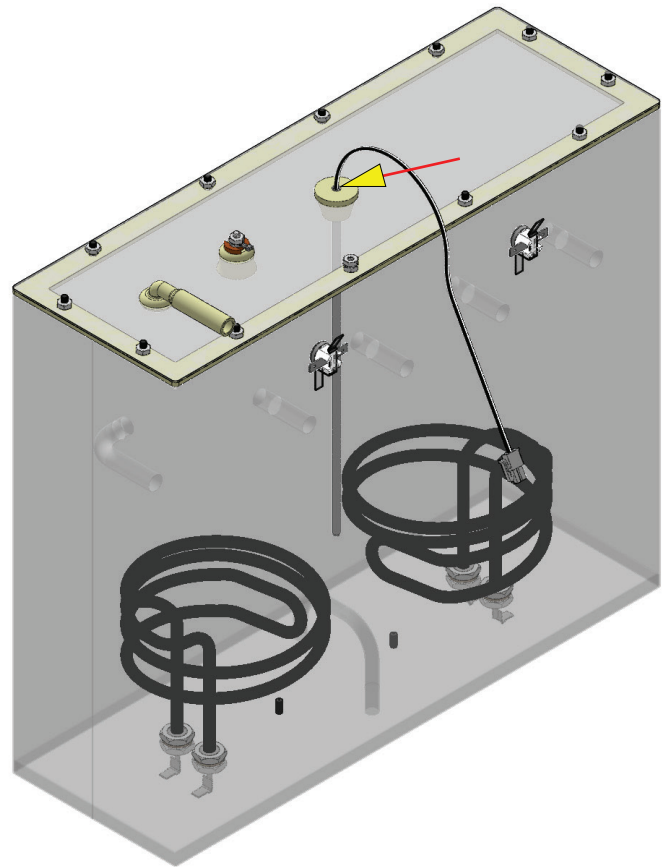

FIG. 19-2 TEMPERATURE PROBE

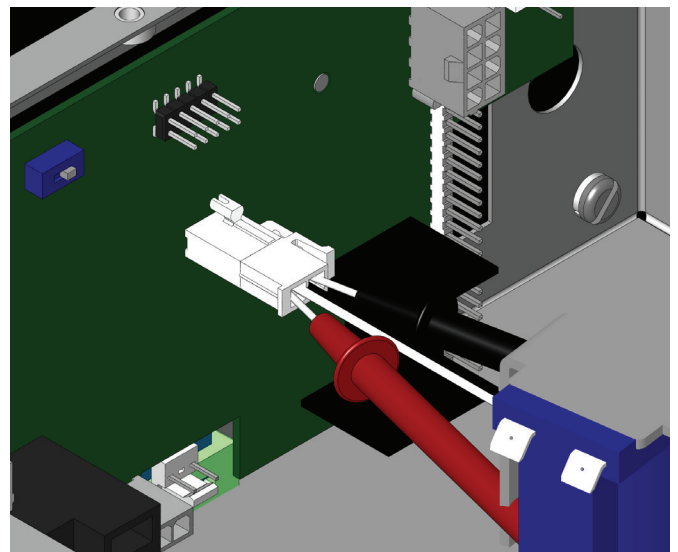

FIG. 19-3 TESTING TEMPERATURE PROBE

CONTINUED

Removal and Replacement:

TEMPERATURE PROBE

1. Disconnect the brewer from the power source.
2. Disconnect the two pin connector from J9 on control board.
3. Pull temperature probe out of it's grommet.
4. Install in reverse order.

Calibration:

1. Remove silicon vent fitting from tank lid.
2. Insert a digital temp probe through the exposed vent hole in tank lid to the same depth as the factory temp probe. FIG 20-1.
3. Press and hold the "Hidden" button until display

- reads "CAL TEMPERATURE SENSOR?" "NO/YES"
4. Select "YES". The display should show something similar to the screen below (FIG 20-2).

NOTE: Variables such as tank set temperature could show different numbers than the example shown here. Tank must be at it's ready temp before calibrating.

5. Press the + (Control) button to increase or - (Digital) button to decrease temperature reading until it matches the reading on the thermometer.
6. Exit program mode, remove thermometer, and install vent fitting. Calibration is complete



FIG. 20-1 CALIBRATE TEMP PROBE

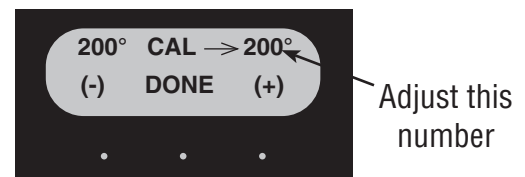

FIG. 20-2 CALIBRATION

VOLTAGE SELECTOR SWITCH



FIG. 21-1 VOLTAGE SELECTOR SWITCH

Location:

The voltage selector switch is located on the component mounting bracket on the base plate.

Test Procedure:

1. Disconnect the brewer from the power source.
2. Disconnect the wires from the selector switch. With the selector switch in the 120V position, check for continuity between the two right terminals of the switch.
3. With the selector switch in the 120/208-240V position, check for continuity between the two left terminals.

If continuity is not present as described, replace the switch.

Removal and Replacement:

1. Disconnect the brewer from the power source.
2. Disconnect the three wires from the selector switch.
3. Remove the switch mounting nut from the under side of component mounting bracket; remove switch from bracket.
4. Install new switch in component mounting bracket and secure with mounting nut.

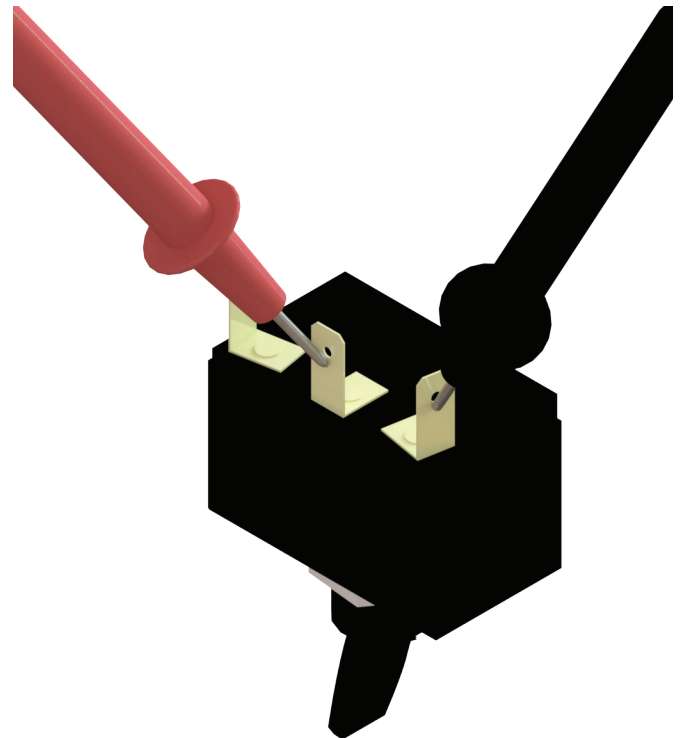

FIG. 21-2 VOLTAGE SELECTOR SWITCH TERMINALS

POWER SWITCH

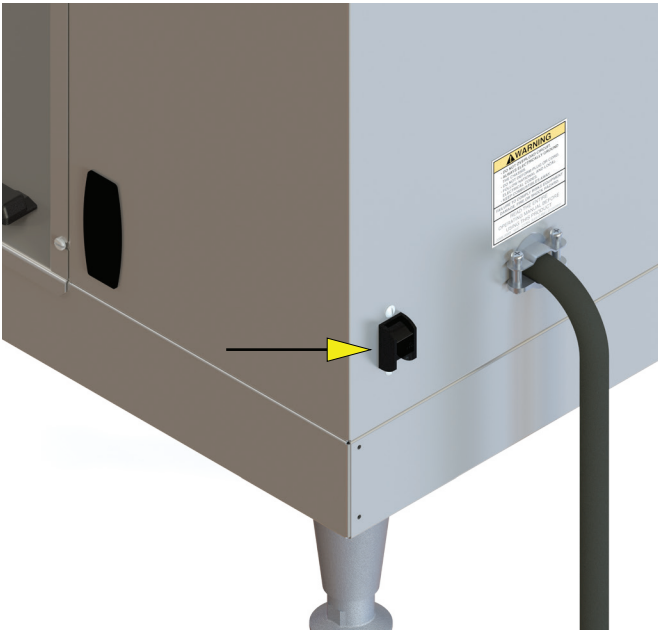

FIG. 22-1 POWER SWITCH (ICB SHOWN)

Location:

The power switch is located on the lower right side of the trunk (ICB) or lower rear panel (ITCB).

Test Procedure:

1. Disconnect the brewer from the power source.
2. Disconnect the wires from the power switch. With the switch in the ON position, check for continuity between the upper and lower terminals on each side of the switch.

There should be continuity between the two left terminals and between the two right terminals when ON, no continuity when OFF.

If continuity is not present as described, replace the switch.

Removal and Replacement:

1. Disconnect the brewer from the power source.
2. Disconnect the wires from the power switch.
3. Remove the switch mounting screws from the left side of trunk.
4. Install new switch in trunk with the two 6-32 x 1/4" mounting screws.

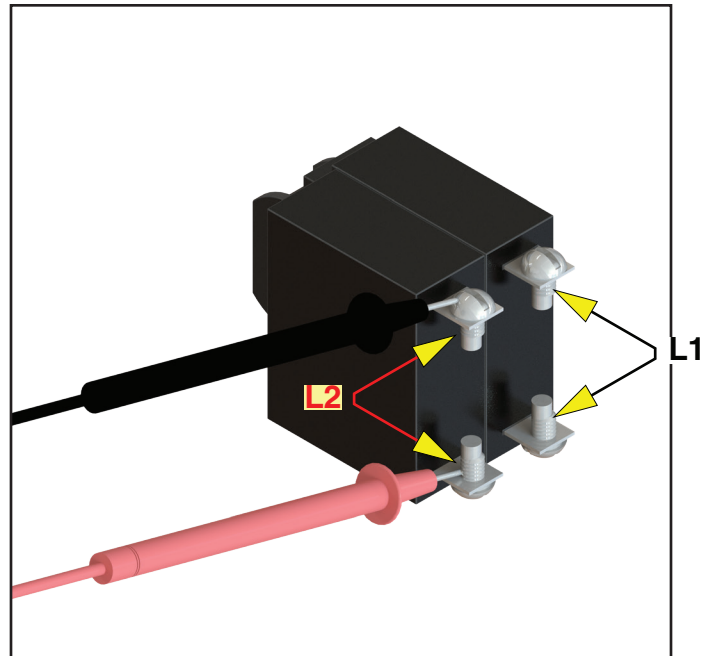

FIG. 22-2 POWER SWITCH

HEATER TRIAC W/HEAT SINK

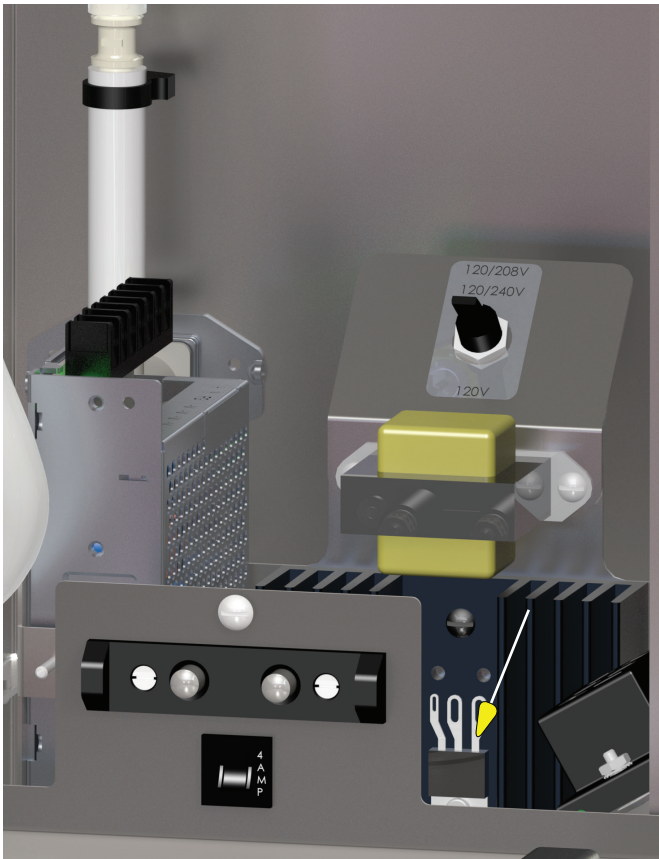

FIG. 33-1 HEATER TRIAC

Location:

The triac is located on the heat sink block located under the water tank assembly.

Test Procedure: Infusion Series®

1. Ensure programming lockout switch in unlocked on the control board. (Fig. 33-2)
2. To access the level 2 function screens press and hold the right hidden button for approximately 5 seconds.
3. The programming of the brewer is divided into four main categories: Recipes, Calibration, Settings, and Service.
4. Access "Service" menu and enter "Test Outputs" menu. (Fig. 33-3)
5. Scroll to "Tank Heater Triac" menu.
6. Install amp clamp around T1 - blue wire going to limit thermostat.

Note: No current or amp reading should be shown on amp meter until activated by the Tank Heater Triac button.

7. Touch the Tank Heater Triac button to activate triac. Current should be present on the amp meter along with the word On flashing on the screen and return to zero amp draw when flashing the word Off on screen.
8. Current shown on meter before activation could mean you have a defective control board or a shorted triac. Disconnect the Gate -Tan wire from the control board.
Current continues - replace heater triac. Also, check tank heater for shorted condition.

Removal and Replacement:

1. Disconnect the brewer from the power source.
2. Disconnect the three triac wires going to the machine components and/or harness connector.
3. Remove triac from the heat sink block.
4. Ensure the new triac has heat sink compound evenly spread on triac plate before securing triac to heat sink block.
5. Install new triac onto heat sink block and secure with screw.

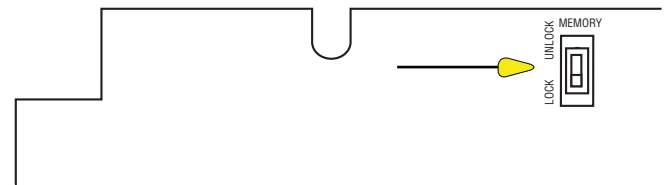

FIG. 33-2 Program Lockout Switch

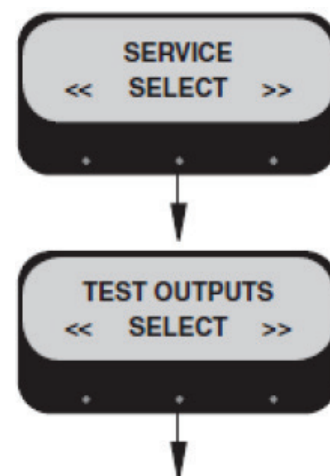

FIG. 33-3 Service Menus

HEATER TRIAC W/HEAT SINK

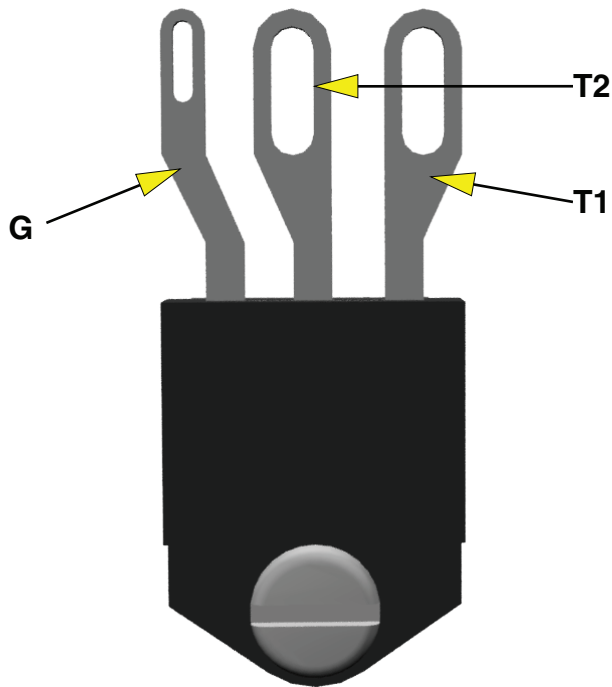

FIG. 33-4 HEATER TRIAC

Test Procedure: Platinum Edition®

1. Access Service Menu in programming. Select Test Outputs menu.
2. When the Tank Heater Triac button is selected, the user/technician will be taken to the tank heater screen. This will show current tank temperature.
3. Install amp meter clamp around triac T1 wire (blue wire going to limit thermostat).
Note: No current or amp reading should be present on amp meter until Start button is depressed. If current is shown on amp meter before depressing the Start button, this could mean that the triac has failed in a shorted condition.
 Disconnect triac Gate wire going to the I/O board.
 Current draw stops - I/O board failure
 Current draw continues - Triac failure (shorted condition)
4. Pressing start will turn the heater on (start button will gray out), the temperature will be captured in real time so the user/technician can see if the water temperature is rising to ensure the heater is functioning properly. The word "Heating" will display on the screen as another hint to let the user/technician know the machines heater is in an active state. The user/technician must shut the heater off

and ensure no amp draw is present on the amp meter before exiting this screen. When stop has been selected the text on the screen should also toggle back to say current tank temperature.

No heat or rise in temperature - Check tank heater, limit thermostat and I/O board.

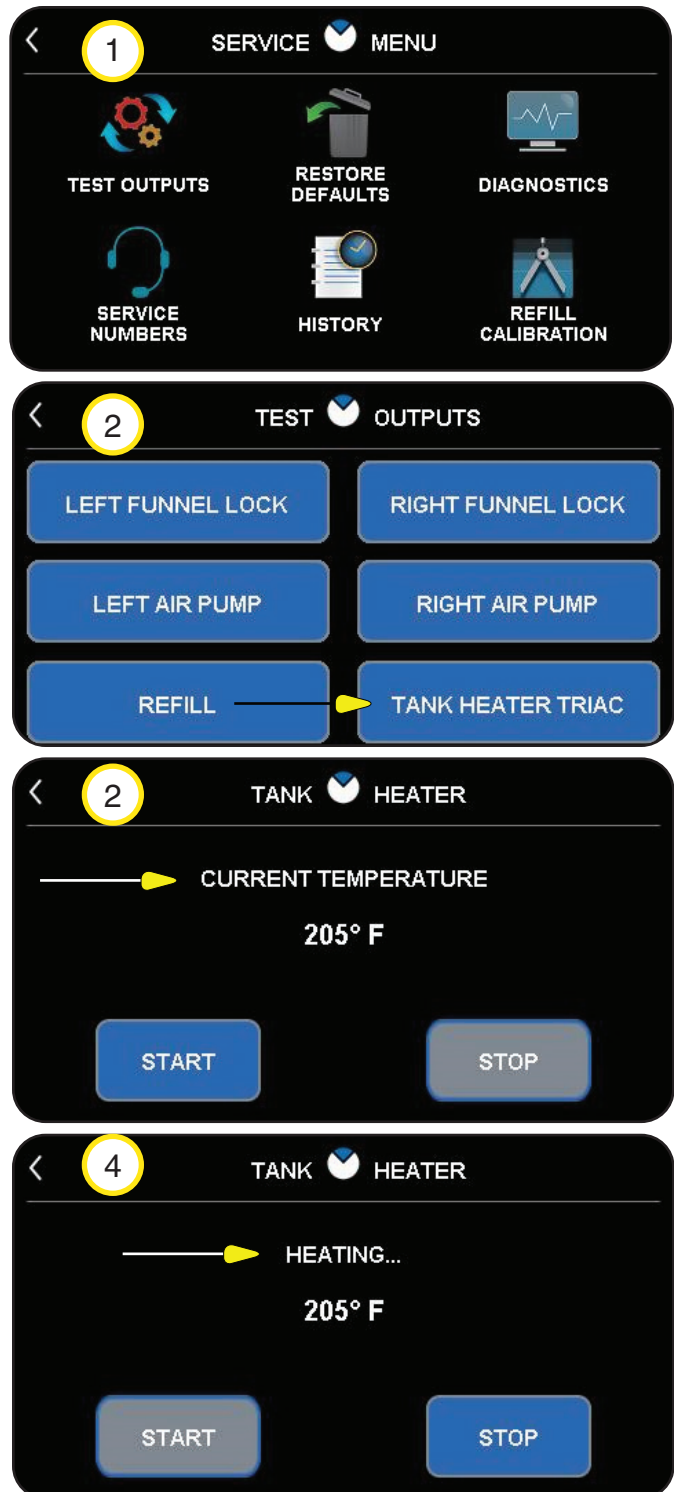

FIG. 33-5 SERVICE MENUS (PE)

SOFTHEAT POWER

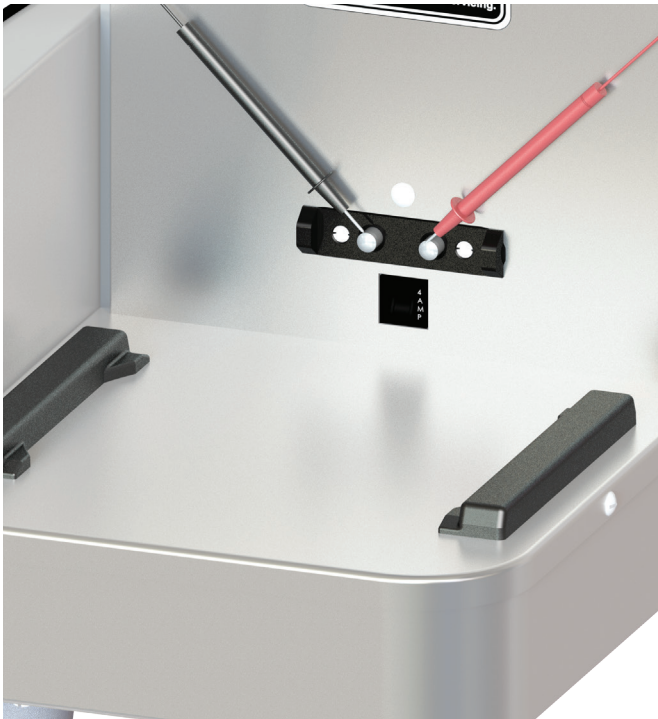

FIG. 23-1 SOFTHEAT CONTACTS

Location:

The SoftHeat contacts are located on the lower front of the trunk.

Test Procedure:

1. Check circuit breaker, reset if tripped.
2. Remove server(s).
3. Set meter to DC 24 volts scale. Check for 24VDC between the right (+) and left (-) terminals. Fig. 23-1.

If voltage is not present as described, continue to # 4.

4. Remove front panel . Verify LED is illuminated. Fig. 23-2 & 3.
5. If illuminated, Check output of power supply for 24VDC. If not illuminated, Set meter to AC 208-240 volts scale (depending on the incoming line voltage). Place the meter probes on the power supply "Line in" terminals. Voltage should read about the same as line voltage across main terminal block.

Removal and Replacement:

1. Disconnect the brewer from the power source.
2. Disconnect the wires from the power supply.

3. On the Twin, remove two screws securing power supply to base. On the single, remove two screws securing component mounting bracket to base, then remove four screws securing power supply to component mounting bracket. **NOTE:** When installing new power supply, verify the voltage selector switch is set to the proper voltage.

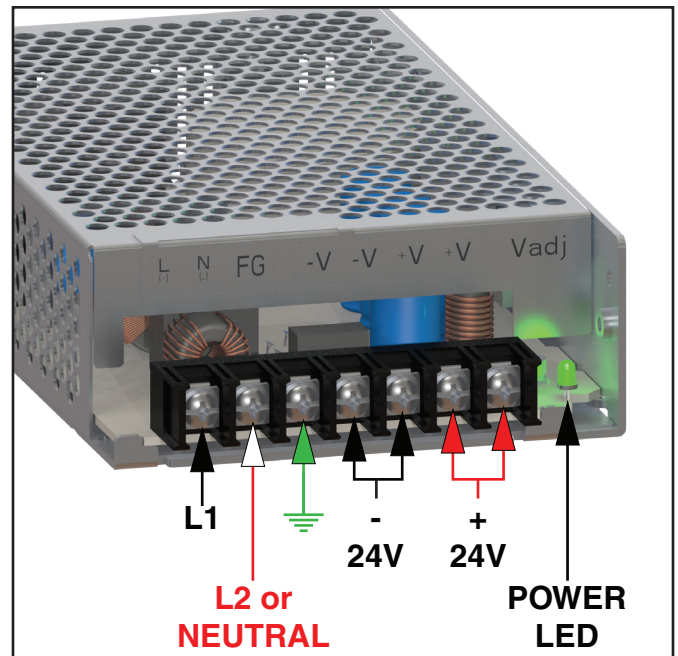

FIG. 23-2 SH POWER SUPPLY

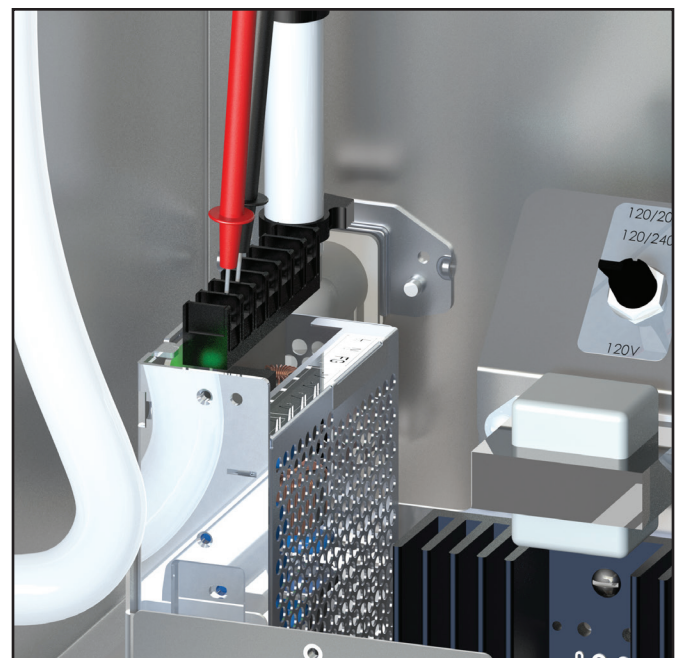

FIG. 23-3 TEST OUTPUTS

TRANSFORMER

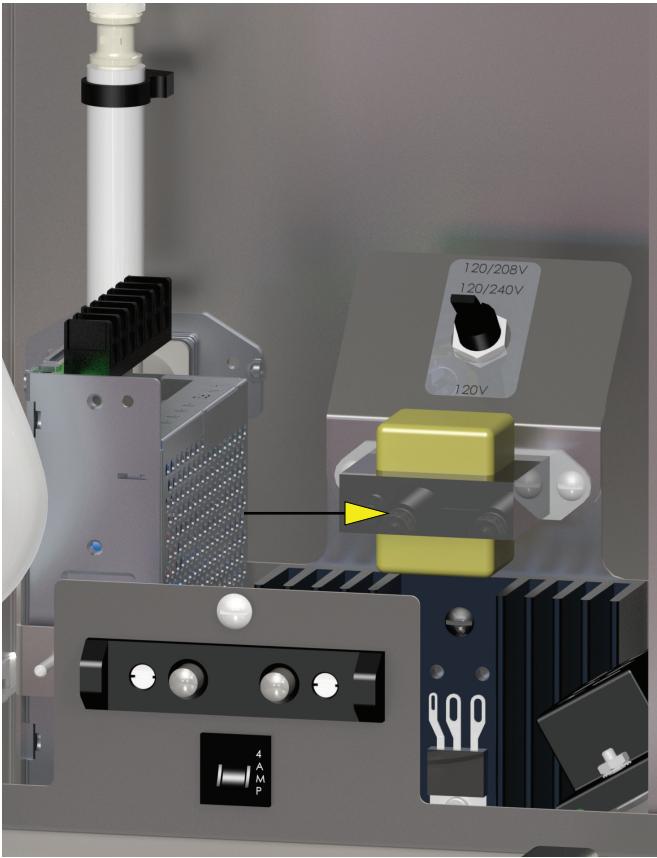

FIG. 24-1 TRANSFORMER

Location:

The transformer is located on the component mounting bracket on the base plate.

Test Procedure:

Transformer: 120VAC - Primary (Black & White)
12.0VAC - Secondary (Yellow & Yellow)

Transformer failures usually result from short circuits on the load side of the transformer which can produce internal heat, breaking down the transformer winding insulation resulting in failure. Inspect transformer visually for bulge or burn marks.

1. Primary Side: Measure voltage across the primary side of the transformer with the input wires connected and measure the input voltage across the wires when disconnected. The volt reading should relatively be the same. If the volt reading is much lower across the transformer, this is a possible indication of a faulty transformer.

2. Secondary Side: Measure voltage across the secondary side when the load is connected. The volt reading should be the expected value of the step down rating. If the step down volt reading is extremely low or zero, this is an indication of a possible shorted load component in the circuit which could damage the transformer too.

Removal and Replacement:

1. Disconnect the brewer from the power source.
2. Disconnect the transformer 5 pin wire connector.
3. Remove the transformer mounting screws to remove transformer from mounting bracket.
4. Install new transformer and secure with the screws from step 3.
5. Reconnect transformer 5 pin wire connector.

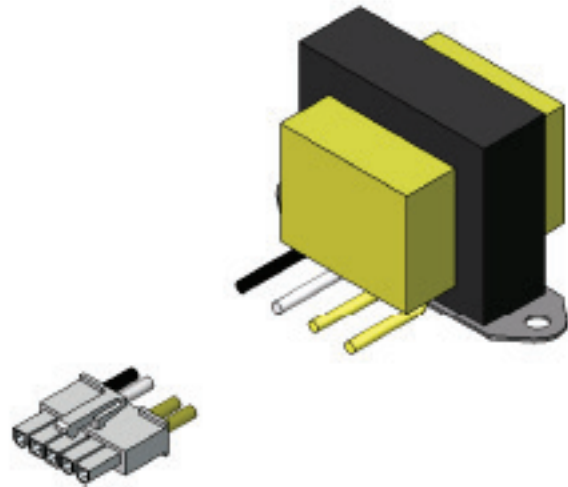

FIG. 24-2 TRANSFORMER

TROUBLESHOOTING SOFT HEAT FEATURE AT BREWER:

Issue: SH server lights not working when sitting on brewer

1. Check to make sure server is fully engaged and touching brewer contacts.
2. Check brewer contacts with multimeter, should be getting 24 VDC
3. If no power is showing up at brewer contacts remove front panel. Power off brewer, check that wiring connections to the back of the contacts are secure and not loose. Tighten if loose and power back up to confirm 24 VDC with multimeter
4. If connections are secure take off platform cover and look at PLC board. Make sure there is no water or coffee on the PLC board or other visible damage. If there is evidence of drips, please check server guide rails. They should fully tightened with a sealing washer, replace if necessary.
5. The Green LED on the 24VDC Supply, located to the right of the terminal block, should be ON.
6. Check connection J3-16 and J3-8 (red and black wire coming from power supply) are giving 24VDC to the PLC board. If not getting adequate voltage check connections on power supply, ensure L1 & L2 are supplying 208V or 240V on standard models or 120V from L1 and N if DV.
7. If voltage properly routed to power supply, but not seeing 24 VDC at J3-16/J3-8, replace power supply (ensure it is flipped to 230V for standard 208V and 240V models or 120V for DV units.)
8. Check that the terminals are fully seated in the J3 Connector.
9. On the PLC Board, the HRT LED (LED1) should be blinking, On for 1 Sec and Off for 1 Sec.
10. Check SH Server LEDs on another Brewer or Stand.

Issue: SH Server lights up, but doesn't turn solid after brew (standard slow blink)

1. Check to make sure server is fully engaged and touching brewer contacts
2. Check brewer contacts with multimeter, should be getting 24 VDC
3. Enter program mode, go to Service, and toggle to SH Version # screen. Readout should show PLC App 01.XX and PLC Boot 01.XX, if this doesn't show up on the second line, please check harness connection at J9 on main board (wht/grn/blk wires). If connections are showing good, check PLC board for any signs of damage.
4. On the PLC Board, the HRT LED (LED1) should be blinking, On for 1 Sec and Off for 1 Sec.
5. If SH Version # is reading for PLC board, next check to see if the server itself is being read. Also under service and SH Version# the screen should read SH 01.XX on the top line. Note that the SH Server must be docked at the Brewer for 10 to 20 seconds before the SH Version# screen is entered.
6. If SH version is being detected, but still blinking after brews, the conductance probes in the faucet shank of server could be dirty or covered. Empty server, remove faucet shank, and take wire brush to clean out server. Build up of coffee grounds and coffee could prevent server from seeing product and create a nuisance trip where the server thinks it is empty.

Issue: SH server blinks rapidly after brew completed.

1. SH server has an error, try brewing into it again. If failure continues to happen to this lone server, please have it replaced.

Issue: SH brewer not detecting server stand (Wireless models only)

1. Ensure server stand is a wireless model, data plate will denote model type with wireless in description. If not a wireless server stand a wireless kit will need to be ordered.
2. If the server stand is a wireless model, check first to see if contacts are showing 24 VDC.
3. Take off stand cover, check to ensure all 3 LEDs are lighting up on wireless PLC that the HRT LED is flashing On for 1 Sec, and Off for 1 Sec. The BT LED will be ON if the Stand is part of a Wireless Network or flashing if it is searching. The WIFI LED should be OFF in a Stand

TROUBLESHOOTING SOFT HEAT FEATURE AT BREWER:

4. Check to make sure nothing metal is sitting under server stand or metal walls blocking signal for server stand to brewer. (Stand may need repositioned close or away from material that will block the radio signal)

Issue: SH stand dropping from webpage dashboard (Wireless models only)

1. Check under dashboard configuration for Brewer that network is locked (Areas with high traffic of Bluetooth and wifi create potential for connectivity issues, locking network out after setup will minimize this potential)

TOUCH SCREEN/DISPLAY

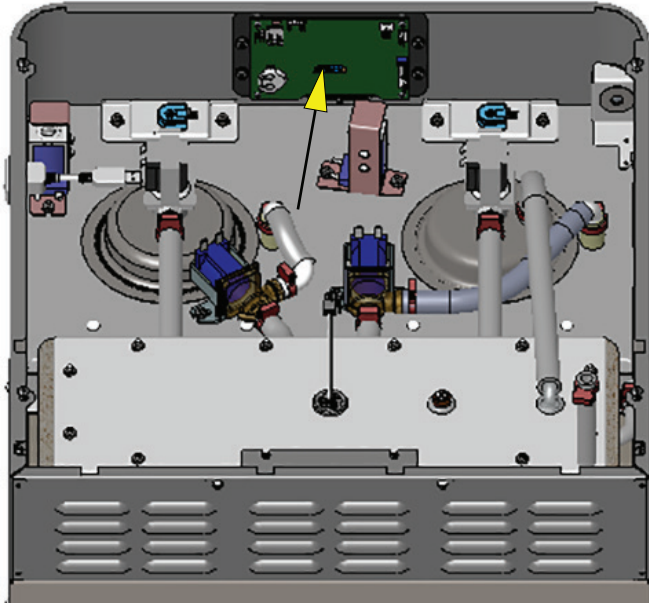

FIG. 25-1 TOUCH SCREEN

Location:

The touch screen is located front center of the hood. Access the touch screen by removing the top cover.

Test Procedure: Input D/C Voltage

1. Disconnect the brewer from the power source.
2. Remove top cover. Locate J10-4 pin connector on touch screen board (Fig. 25-2).
3. Reconnect the brewer to the power source.
4. Apply voltmeter across J10-4 (positive) and J10-2 (negative) terminals. D/C voltage reading must be 13.8VDC or higher.

Voltage input correct but screen is not illuminated, replace touch screen assembly.

Removal and Replacement:

1. Disconnect the brewer from the power source.
2. Disconnect the wire harness connectors from the board.
3. Remove the nuts from the left & right side of the board.
4. Install new touch screen assembly and secure with the nuts removed from step 3.
5. Reconnect the wiring harness connectors.

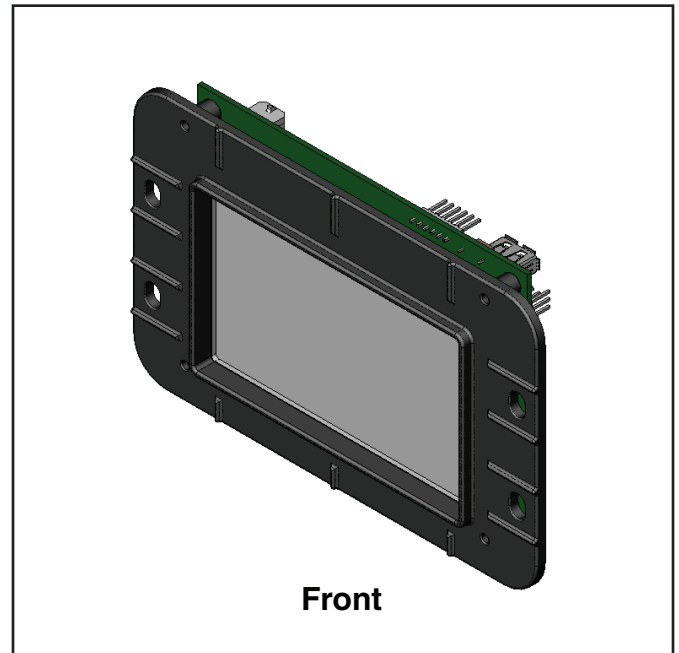
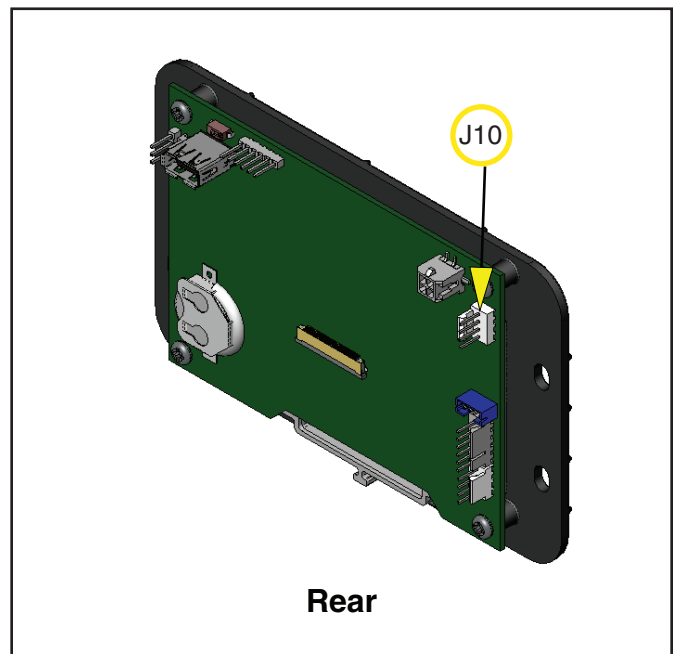

FIG. 25-2 TOUCH SCREEN



BREW/WAVE DISPENSE VALVE

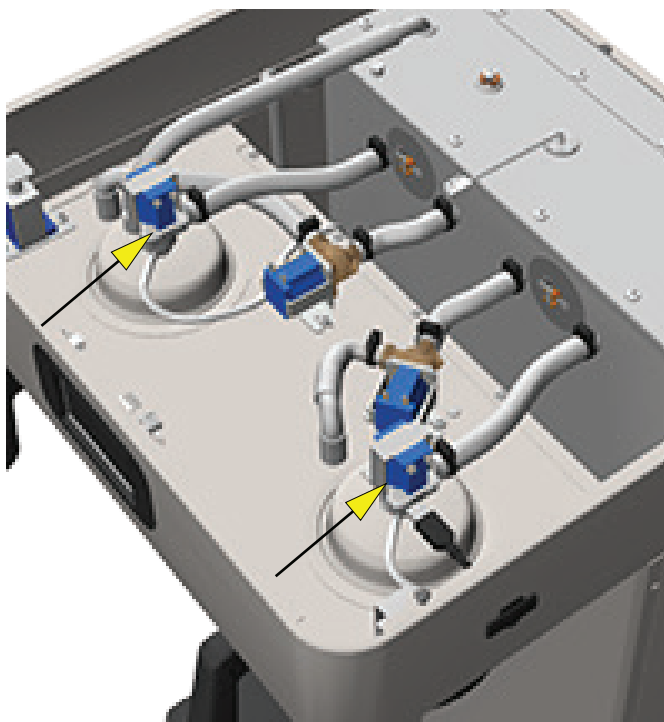

FIG. 26-1 WAVE BREW DISPENSE VALVE

Location:

The wave dispense valve is located inside the top hood behind the front face plate.

Test Procedures:

1. Go into program mode and select the "Service" icon and enter Test Outputs menu.
2. Be sure brew funnel & server are in place before activating valve.
3. Check the valve for coil action. Turn on the valve with the test mode. Listen carefully in the vicinity of the brew valve for a click as the coil pulls the plunger in.

If no sound is heard as described, proceed to #4.
If the sound is heard as described, there may be a blockage in the valve, hose, tank, or sprayhead. Disconnect the brewer from the power source. Remove the valve and inspect for blockage, and de-lime all related areas.

4. Connect the voltmeter leads to the coil terminals. Turn on the valve with the test mode. The indication will be 2-3VAC off, 120VAC on. Set the meter to DC volts. The indication should be 150-160VDC when off, 0V when on. If the polarity of meter leads are reversed, reading will indicate -150-160VDC. **(Double these readings for 240 volt coils)**

If voltage is present as described, but no coil action is observed, valve is defective. Replace valve and test again to verify repair.

Removal and Replacement:

1. Disconnect the brewer from the power source.
2. Drain the water tank below the brew dispense valve water outlet fitting.
3. Disconnect the wires from the brew dispense valve.
4. Disconnect the water inlet tube and air tube going to the brew dispense valve.
5. Unscrew sprayhead to access the nut securing brew dispense valve to the hood panel.
5. Remove the nut securing brew dispense valve.

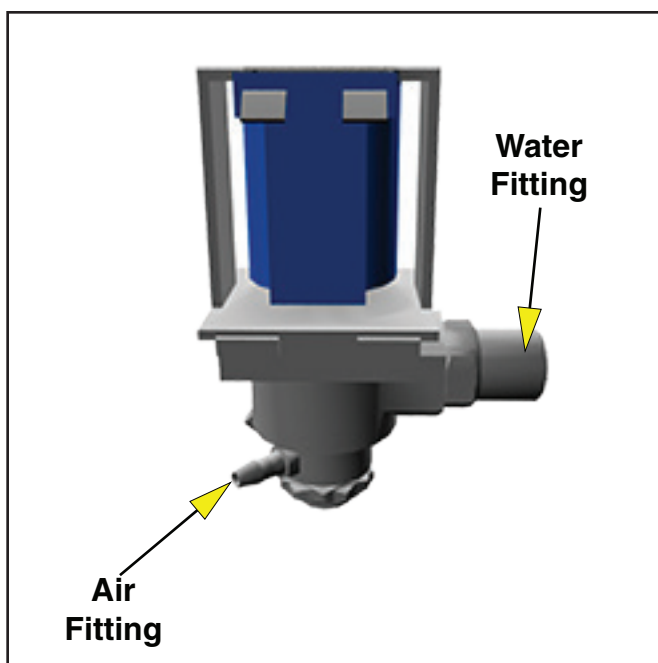

FIG. 26-2 WAVE BREW DISPENSE VALVE

AIR PUMP

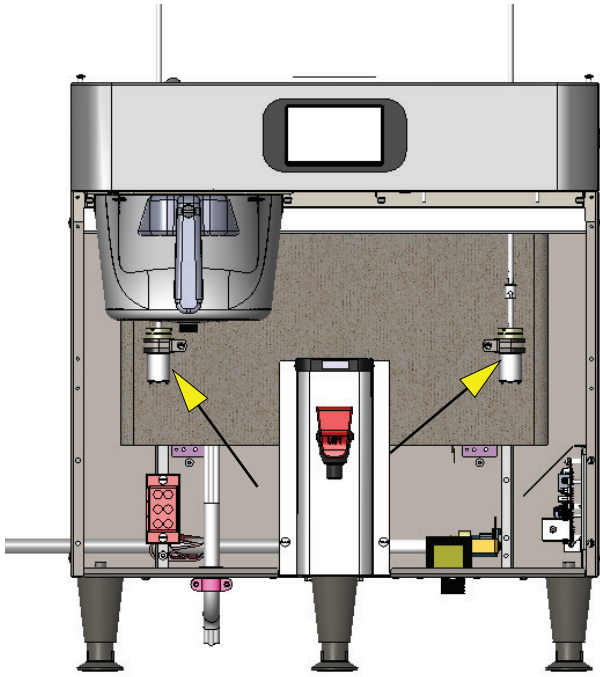

FIG. 27-1 AIR PUMP

Location:

The left & right air pump are located in front behind lower trunk panel.

Test Procedure:

1. Go into program mode and select the "Service" icon and enter Test Outputs menu.
2. Apply voltmeter leads across the air pump terminals being checked for DC voltage at J5-4 pin connector (Fig. 27-3).

J5-4 - BLU Wire: Right air pump (negative wire)

J5-3 - BLU/WHI Wire: Right air pump (positive wire)

J5-2- ORG Wire: Left air pump (negative wire)

J5-1 - ORG/WHI Wire: Left air pump (positive wire)

3. Touch the left or right air pump button to activate the air pump. The volt reading should be approximately around 12.0 to 13.5VDC.

Note: The test is a momentary voltage output.

Voltage Present: Check air pump check valve for blockage before replacing air pump.

Voltage Not Present: Replace I/O Board.

Removal and Replacement:

1. Disconnect the brewer from the power source.
2. Disconnect the air pump wire connector from the main wiring harness.
3. Disconnect tube from air pump barb fitting.
3. Loosen the air pump clamp screw and remove air pump from clamp.

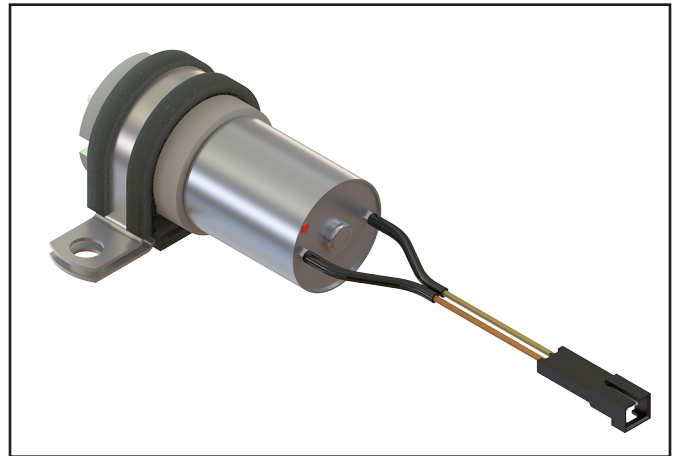

FIG. 27-2 AIR PUMP

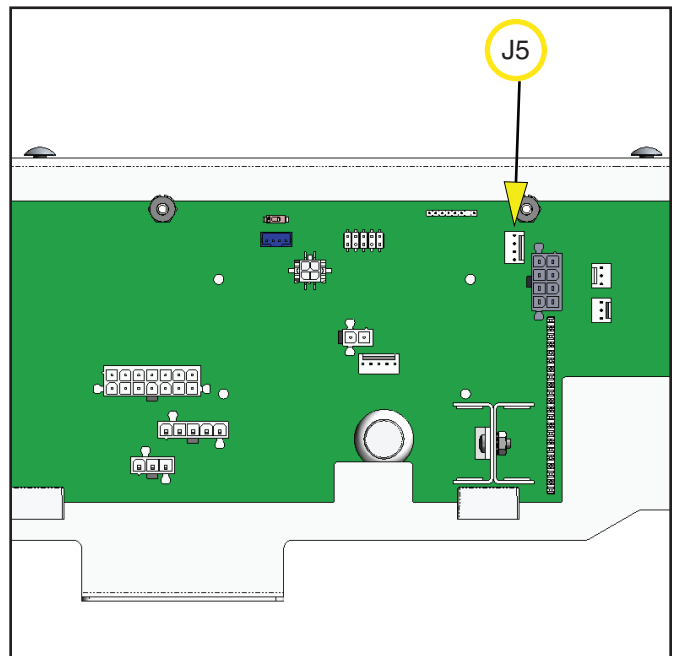

FIG. 27-3 I/O Board J5 Connector

AIR PUMP CHECK VALVE

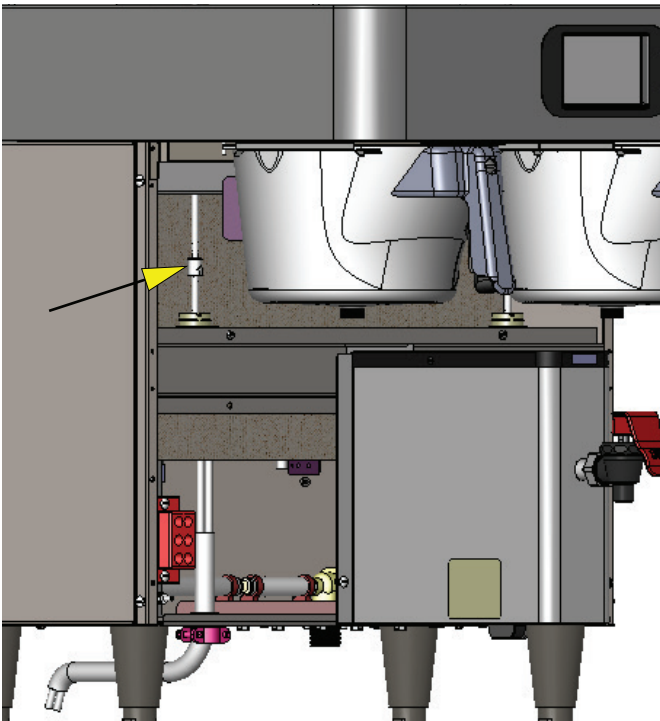

FIG. 28-1 AIR PUMP CHECK VALVES

Location:

The left & right air check valves are located in front behind lower trunk panel.

Test Procedure: Option 1 or 2

Option 1: The check valve prevents water from entering the air pump assembly.

1. Disconnect brewer power and prepare brewer for air pump check valve test by removing top panel.
2. Remove the applicable pump tube at the brew valve base being tested.
3. Reconnect brewer power. Go into program mode and select the "Service" icon and enter Test Outputs menu. Scroll (>) to Air Left & Right Air Pump button.
4. The tube removed from the valve base, place finger over tube outlet. Touch the applicable left or right air pump button. You should feel air pushing on your finger tip. Next, squeeze the end of tube or firmly place finger over tube outlet, the air pump motor will change in tone when blocking and unblocking the air tube outlet.

Option 2: Extension tube will be required for test.

5. The tube removed from the valve base, install the extension tube onto the end of this tube.
6. Place the end of the extension tube into a cup of water away from the brewer.

7. Touch the applicable left or right air pump test button.
8. The water should be bubbling from introduction of air from the air pump through the check valve.

No change in tone, air sensation or bubbling. Check air pump motor for operation and inspect for kinked air pump tube before replacing check valve.

Removal and Replacement:

1. Disconnect the brewer from the power source.
2. Disconnect the tubes from the check valve barb fittings. Replace check valve.

Note: The check valve has an arrow embossed in the valve body to show flow direction.

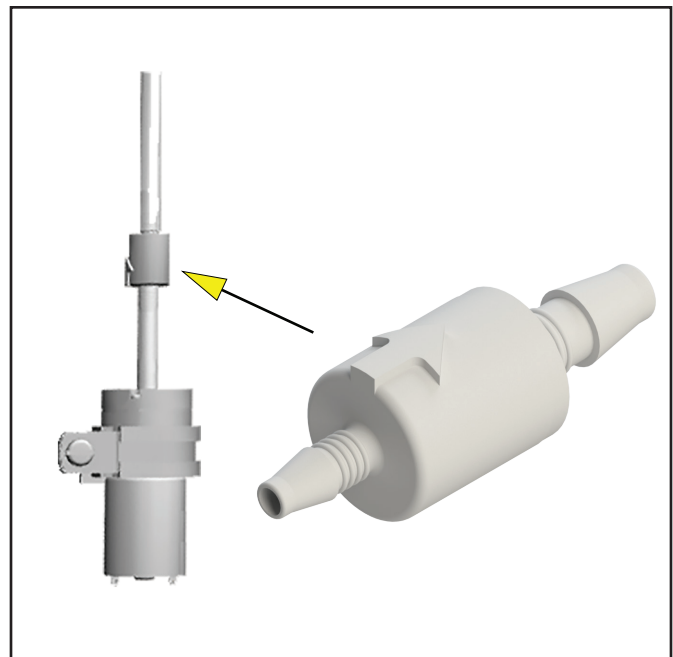

FIG. 28-2 AIR PUMP CHECK VALVE

BREW FUNNEL SENSING COIL

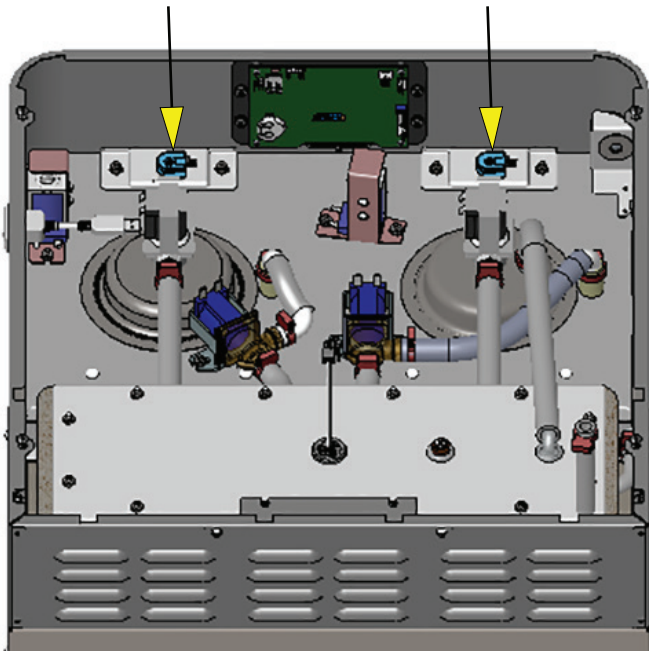

FIG. 29-1 BREW FUNNEL SENSING COIL

Location:

The brew funnel sensing coils are located inside the top hood behind the front face plate.

Test Procedure:

Note: The I/O Diagnostics menu will give current status of different operations done by the Brewer IO Board.

1. Go into program mode and select the "Service" icon and enter Diagnostics menu.
2. Select and touch the I/O Diagnostics button.
3. Use the scroll arrow (upper right corner) to move forward to the next screen.
4. The funnel sensing coil "RFID Frequency" must read between 124.0 - 127.0 kz (Fig. 29-3)

Frequency low or out of range - First, inspect harness and connector for an open connection between the funnel sensing coil and the I/O board before replacing funnel sensing coil.

Removal and Replacement:

1. Disconnect the brewer from the power source.
2. Disconnect the wire connector from the funnel sensing coil.
3. Remove the coil mounting plate nuts.
4. Release center push in fastener from funnel sensing coil. Replace sensing coil.

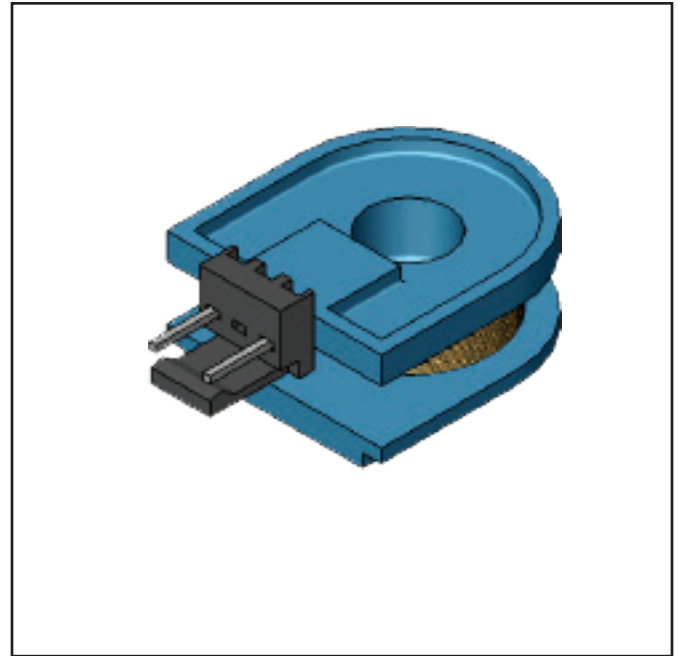

FIG. 29-2 BREW FUNNEL SENSING COIL

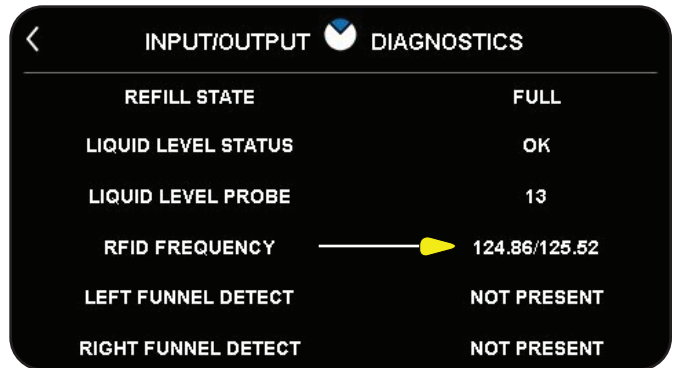

FIG. 29-3 SENSING COIL RFID FREQUENCY

FUNNEL LOCK SOLENOID

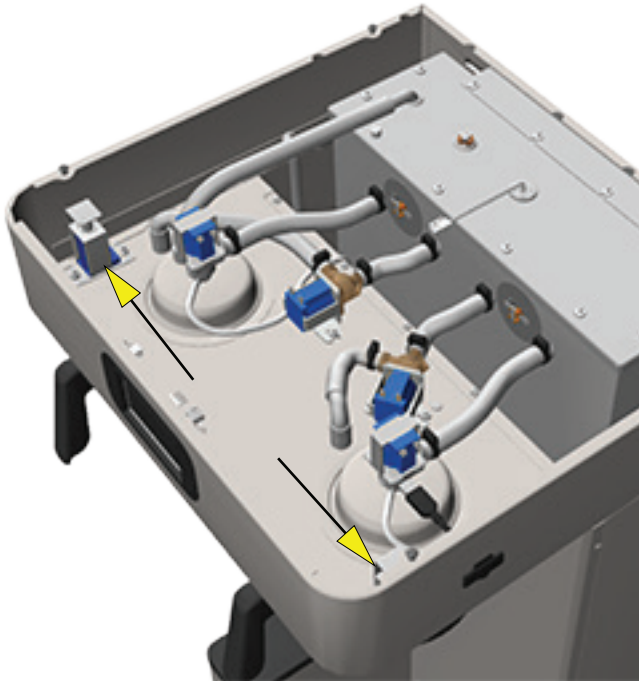

FIG. 30-1 FUNNEL LOCK SOLENOID

Location:

The funnel lock solenoid is located inside the top hood behind the front face plate.

Test Procedure:

1. Go into the software menu and select the "Service" icon and enter Test Outputs menu.
2. Be sure brew funnel & server are in place before activating funnel lock solenoid.
3. Check the funnel lock for action. Select and touch the funnel lock button to activate the funnel coil, plunger should drop down in front of brew funnel. (Fig. 30-3)
4. Install meter leads across funnel lock coil terminals while wires are still attached. Turn on funnel lock, 110.0VDC or slightly lower will be present on the voltmeter display and drop down to 85.0VDC after 2 seconds. Funnel lock turned off, voltage will go 00.0 VDC.

Voltage present & zero action: Replace funnel lock solenoid.

Voltage not present: Replace I/O board and check for shorted funnel lock coil.

Removal and Replacement:

1. Disconnect the brewer from the power source.
2. Disconnect the wires from the funnel lock solenoid coil.
3. Remove the 2 nuts securing the funnel lock solenoid to the hood plate.

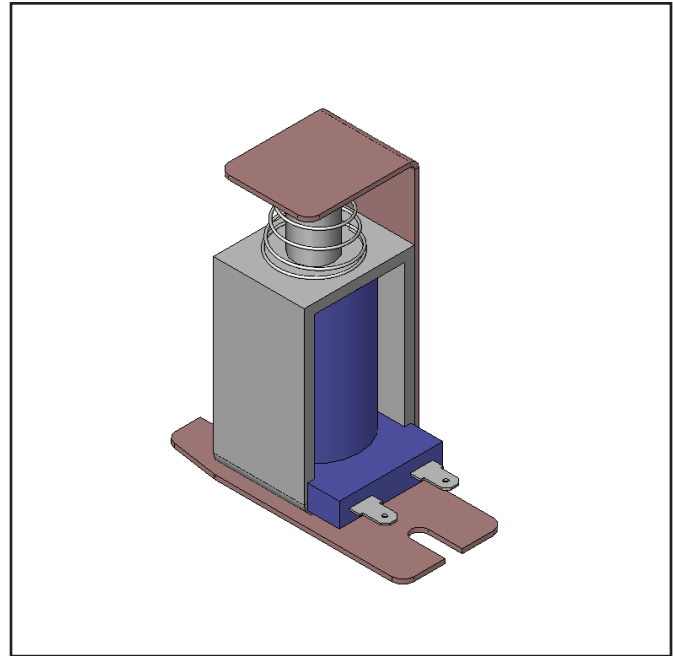

FIG. 30-2 FUNNEL LOCK SOLENOID

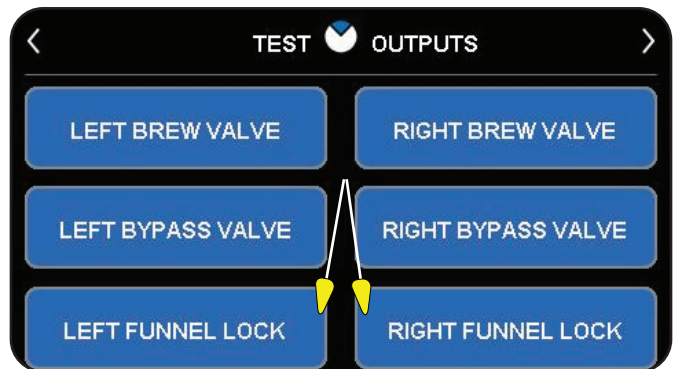

FIG. 30-3 FUNNEL LOCK SOLENOID

INPUT/OUTPUT BOARD

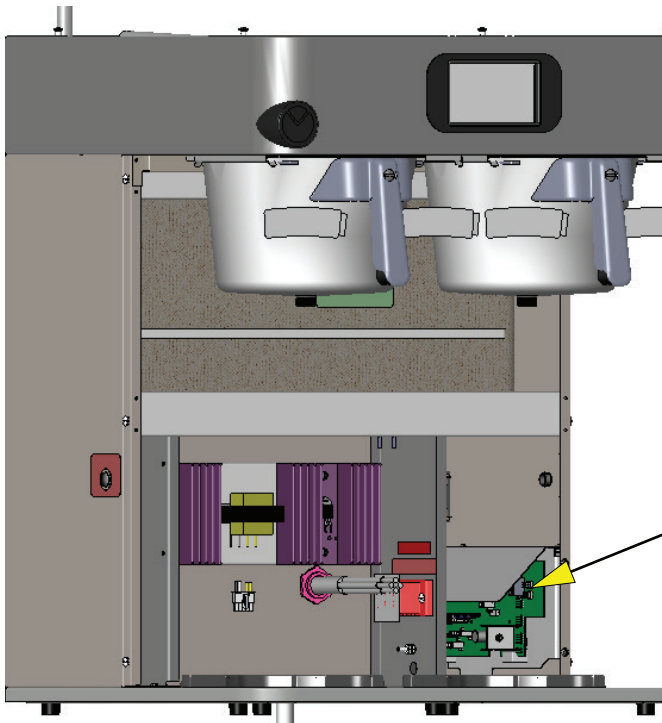

FIG. 31-1 I/O BOARD

Location:

The I/O board is located lower right front behind lower trunk panel.

Test Procedure:

Note: Ensure the main brewer On/Off switch is turned on.

1. Apply voltmeter leads across terminals J15-5 & J15-4 on the I/O board. The meter reading will be 12.0VAC.
2. Check I/O board J15-1 & J15-2 for 120VAC output going to the primary side of the transformer.
3. No 120VAC output - Replace I/O board.
4. Verify I/O board D/C output to PLC board.
5. Disconnect J4 connector from I/O board.
6. Install voltmeter leads across J4-4 (positive) and J4-2 (negative) male terminal pins on the I/O board.
7. The reading must be 15.8VDC +/- 10%.
8. Voltage not present - Replace I/O board.

I/O Board J4-4 Pin Connector

- Terminal 1: White Wire, TX
- Terminal 2: Black Wire, Negative/Ground
- Terminal 3: Red Wire, RX
- Terminal 4: Green Wire, Positive/Input

Error Message

If the board is not receiving the proper commands or a loss of communications occurs this screen will be displayed (Fig. 31-3)

Removal and Replacement:

1. Disconnect the brewer from the power source.
2. Disconnect all wiring harness connectors from the I/O board.
3. Remove the board mounting nuts. Tilt and lift board from bottom mounts.

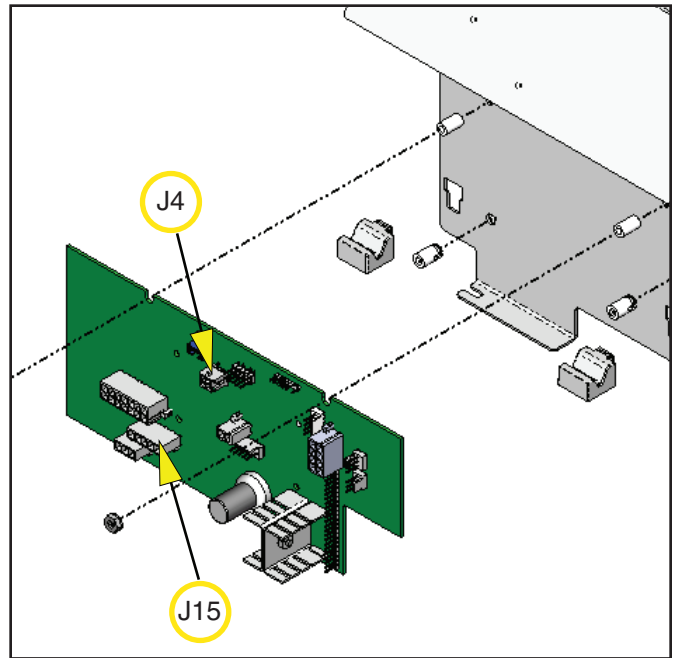

FIG. 31-2 I/O BOARD

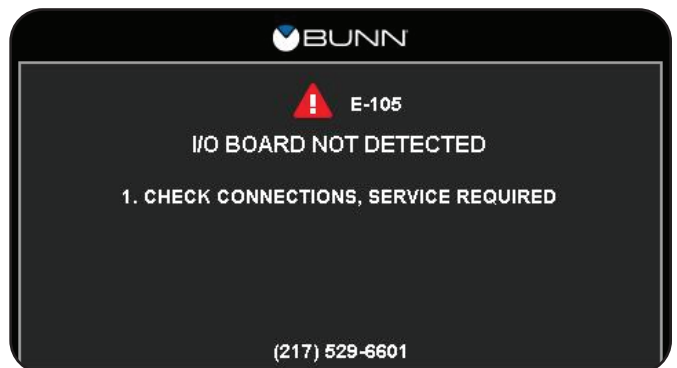

FIG. 31-3 I/O BOARD ERROR MESSAGE

BUNNLink BOARD

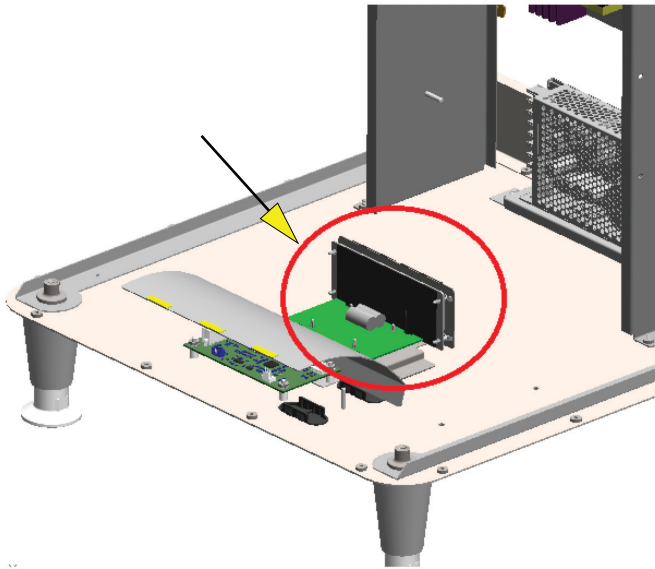

FIG. 32-1 BUNNLink BOARD

Location:

The BUNNLink board is an option that can be found in Infusion Series brewers. The board from the BUNNLink kit installs at the bottom, inside the machine under the water tank. See pictorials next page for approximate placement among Infusion Series models.

Test Procedure:

1. Locate the Qty-5 LEDs on the BUNNlink board.
2. LED #5 should be illuminated solid green to indicate power is connected.
3. LED #5 not illuminated means power is not connected or loss of power.
4. Set voltmeter on DC voltage.
5. Go to 4 pin connector and apply voltmeter leads across terminal 1 (+5V) & 4 (Ground).
6. Voltage input is 5.0VDC.
Voltage present & no LED #5 illumination - Replace BUNNLink board.

Power Input Connector:

- Pin 1 - +5V
- Pin 2 - TX (to brewer)
- Pin 3 - RX (from brewer)
- Pin 4 - Ground

LED Identification:

LED 1 - Solid Green = WiFi board is connected to the cloud.

- Flashing Green = RX/TX to the cloud is in process.
- Off = WiFi board is not connected to the cloud.

LED 2 - Solid Green = WiFi board is detecting the brewer.

- Flashing Green = WiFi board is powering down.
- Off = WiFi board is not detecting the brewer.
-

LED 3 - Not used.

LED4 - Not used.

LED 5 - Solid Green = Power is connected.

- Off = Power is not connected.

Removal and Replacement:

1. Disconnect the brewer from the power source.
2. Disconnect the wiring harness connector (red/yellow/blue/black), USB A, and USB B micro cable.
3. Depress standoff snaps to release board.
4. Assemble new BUNNLink board over the top of the standoff snaps and push to fully secure into place.
5. Reconnect the wiring harness connector (red/yellow/blue/black), USB A, and USB B micro cable.
6. Go to BUNNLink Activation pages for instruction.

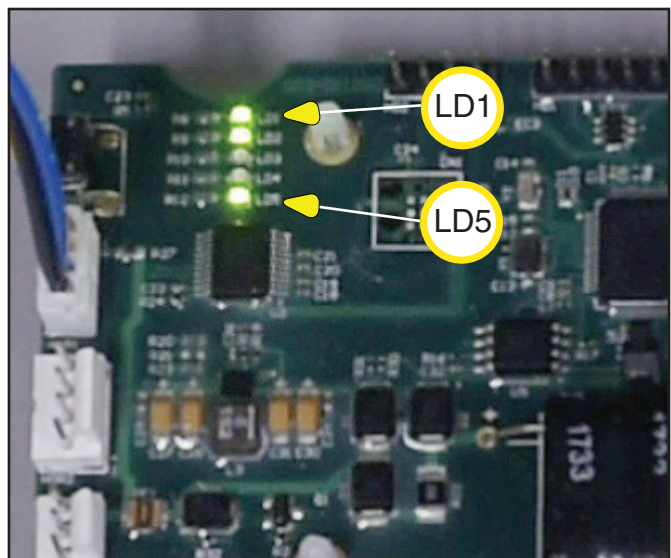

FIG. 32-2 FUNNEL LOCK SOLENOID

FIG. 30-5

PLATINUM EDITION
BUNNLink BOARD - MODEL PLACEMENT

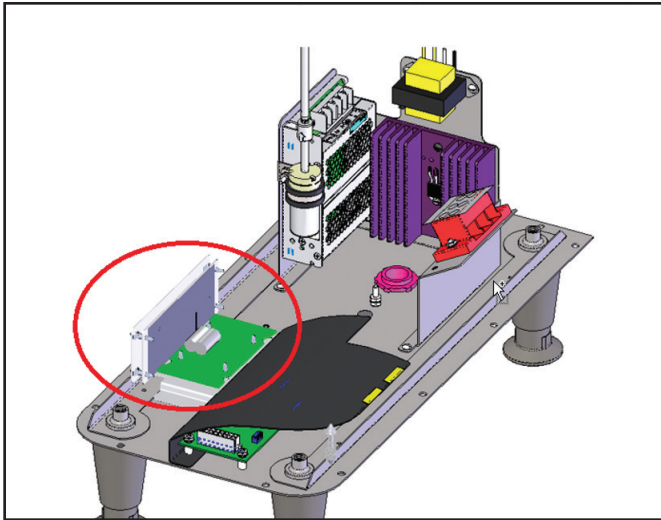

FIG. 33-2 52100.0100 ICB SH PE, 120/240V

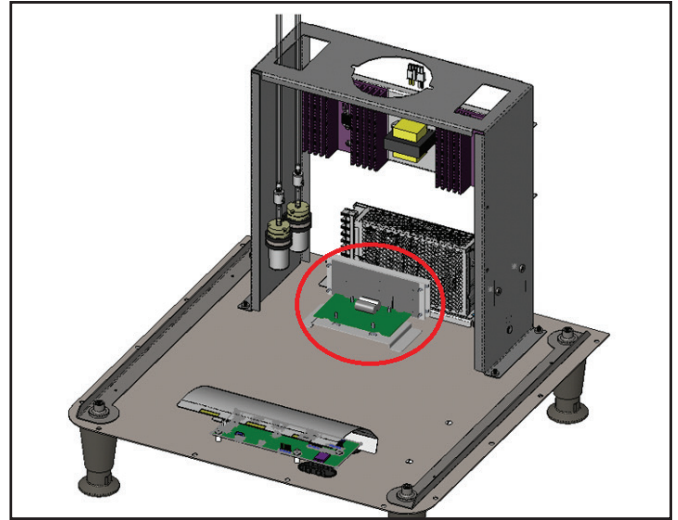

FIG. 33-2 53600.0100 ICB TWIN SH PE, 120/240V SST

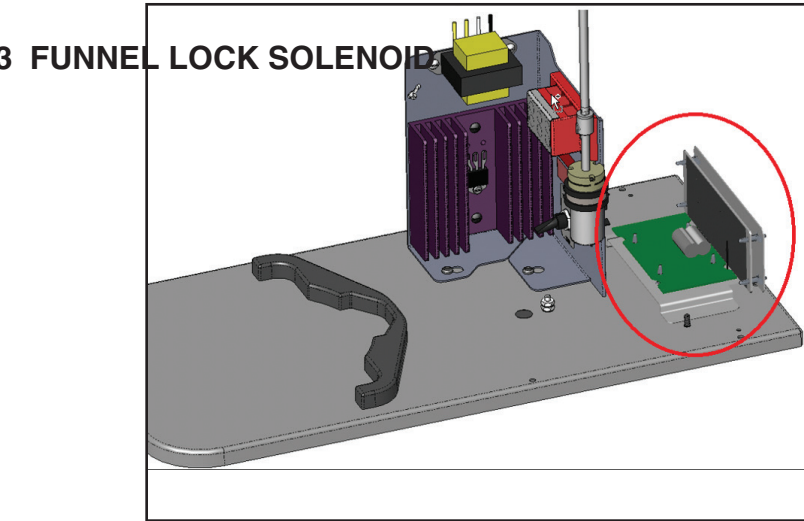

FIG. 33-2 53300.0100 ICB-DV PE, 120V

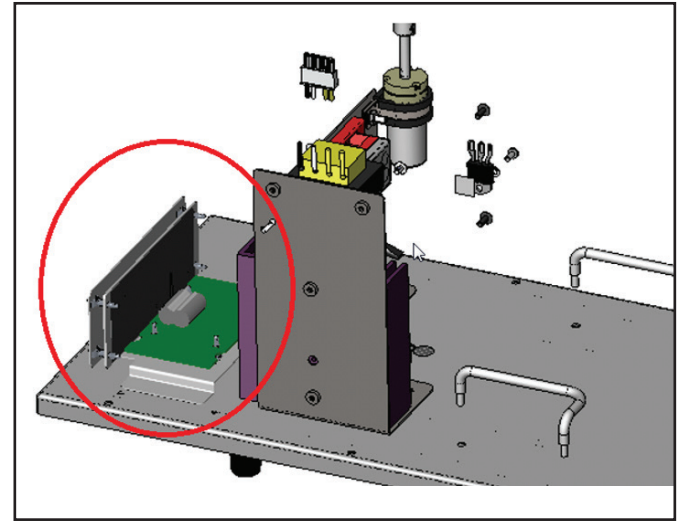

FIG. 33-2 54000.0100 ITCB-DV HV PE, 20/208-240V

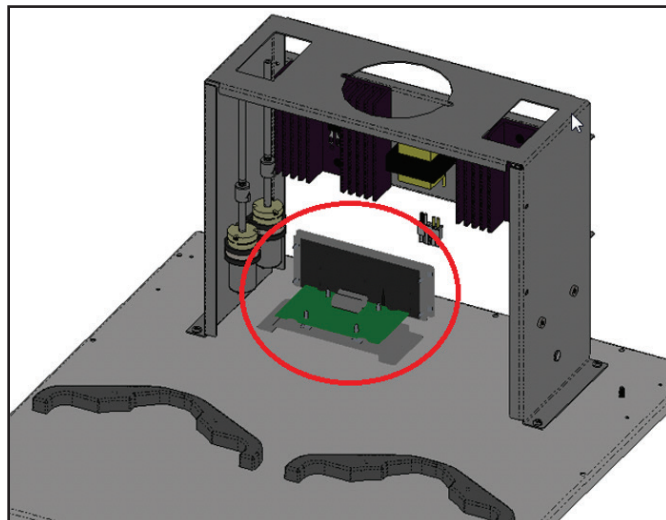

FIG. 33-2 53400.0100 ICB Twin PE, 120/240V SST

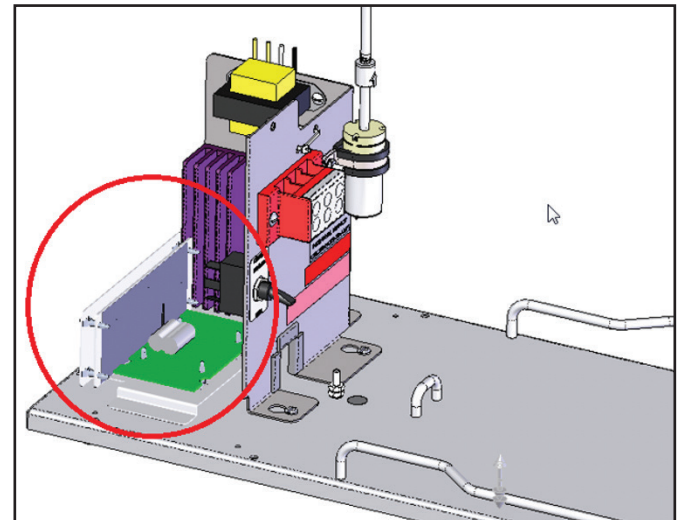

FIG. 33-2 52500.0100 ITCB-DV PE, 29" W/Tray

BUNNLink WIFI ACTIVATION

If you experience any issues with Activation, contact a BUNNlink administrator: bunnlink@bunnlink.com.

1. Access the Wi-Fi Setting page on the device you will be using tablet, laptop, or phone. From the Wi-Fi Setting page locate the Wifi board serial number. This should be on display in the network search area.

* If the Wifi board serial number is not present, power cycle the machine three times. Wait five seconds between cycles to ensure the board has completely shut off*

3. Select the Wifi board serial number. Enter Bunn123! in the password text field.
4. After a connection to the network has been made, open the web browser of your choice (Google, Safari, Mozilla).
5. Enter 192.168.1.1 in the web address bar
6. On the BUNN login page enter the username BunnService. Enter Bunn123! in the password text field. Pres the log in button
7. From the home page select settings from the menu bar.
8. From the drop down menu, choose the desired network to join.
9. Enter the password for the specific networks and press apply.
10. See BUNNLink Brewer Activation page to activate BUNNlink on the brewer.

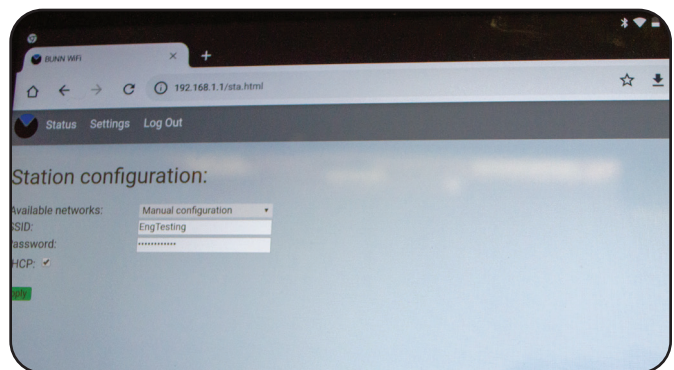
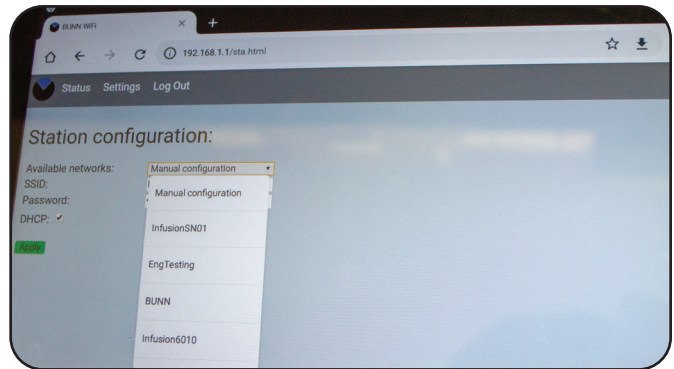
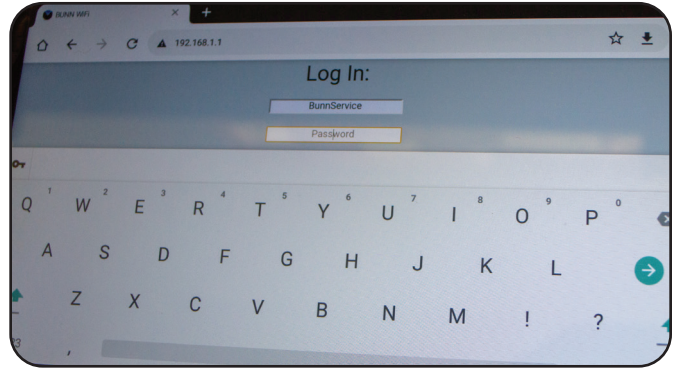
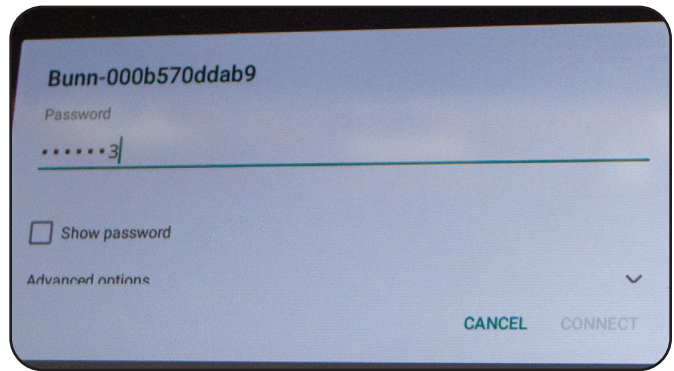

BUNNLink LTE ACTIVATION

If you experience any issues with Activation, contact a BUNNlink administrator: bunnlink@bunnlink.com.

- 1. Scan the QR Code located on the machine. Scan the QR Code sticker located in the package or on the back of the BUNNlink board itself.

*Note the serial number will display and activation date will read “Not Activated”. *



- 2. Once the QR codes is scanned on a smartphone or tablet this screen will display. Enter the pin 6601. When the digits are entered in the text boxes click the submit. The far right image shows an incorrect pin number.

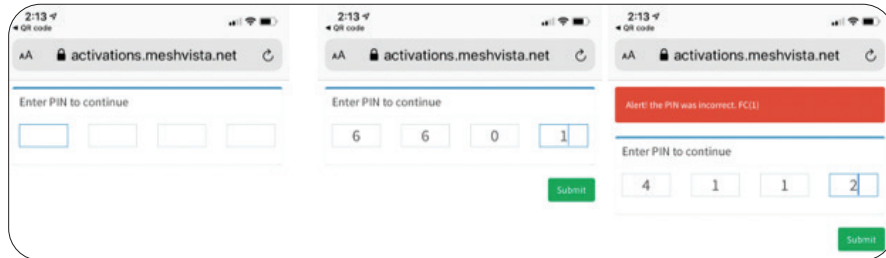

- 3. The activation page shows the MAC address of the board, verify this number matches the IMEI number on the board itself. Press activate to continue. After selecting the activate button there will be a confirmation screen to confirm the activation of the board.

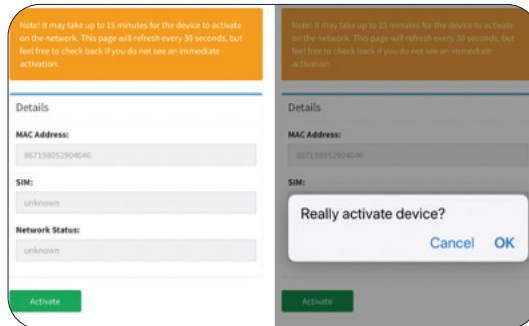

- 4. Upon successful activation this screen will show on the device. Confirm the MAC address and IMEI match. SIM card information, activation date, and the network status will display. Network status is not an indication of the board establishing a cloudlink connection. Activation of the board can take up to fifteen minutes as stated on the activation page. The board is completely activated once the LED changes color from blue to green.

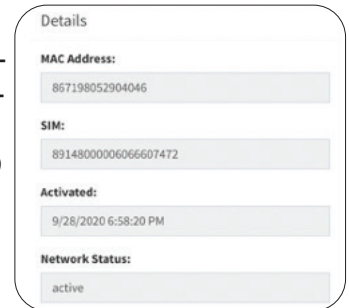

- 5. Verify the gateway has been connected, the machine serial number, signal strength, and cloud link by accessing the BUNNLink tab from machine settings on the unit.

Continued >

- 6. See BUNNLink Brewer Activation page to activate BUNNlink on the brewer.

BUNNLink BREWER ACTIVATION

If you experience any issues with Activation, contact a BUNNlink administrator: bunnlink@bunnlink.com.

1. Hold the BUNN logo for three seconds to access the Service Access screen.

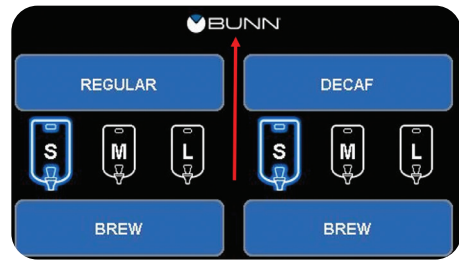

2. From Service Access, select Advanced and enter passcode.

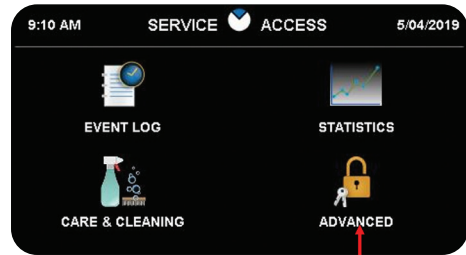

3. From the Advanced Menu select Service icon.

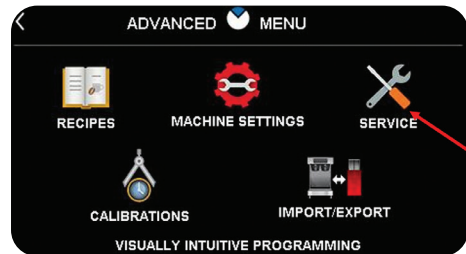

4. Select Diagnostics.

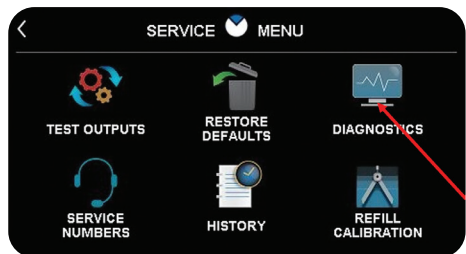

5. Select BUNNlink Diagnostics button.

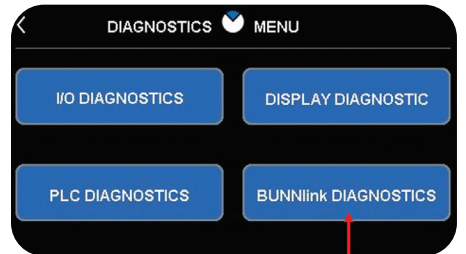

6. Press the Activate BUNNlink button. Once selected the button will change its status to read schedule update.



BUNNLink PRODUCT REGISTRATION

Scan to register your machine on BUNNlink® for reports and further support.

Please provide this QR code to the customer or manager of the site.



LIQUID LEVEL PROBE

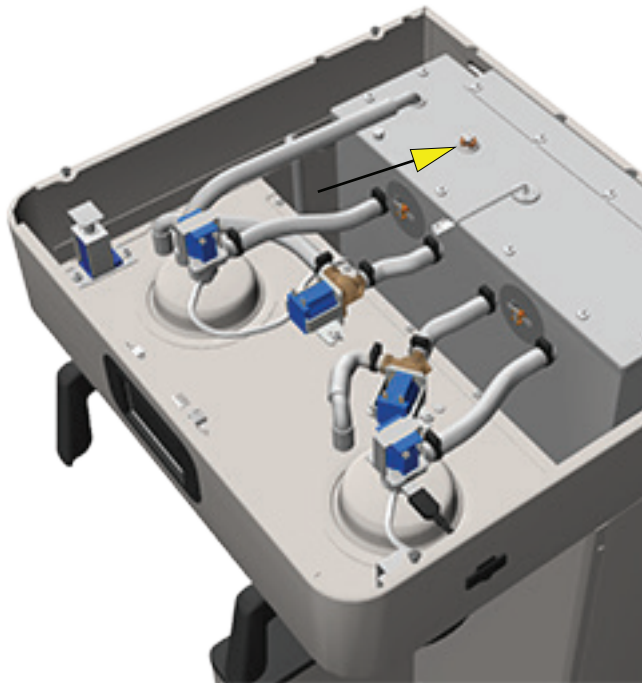

FIG. 34-1 LIQUID LEVEL PROBE

Location:

The liquid level probe is located inside the top hood on the tank lid.

Test Procedure:

1. Go into the software menu and select the "Service" icon and enter Diagnostics menu.
2. Select and touch the I/O Diagnostics button.
3. Use the scroll arrow (upper right corner) to move forward to the next screen.
4. Refill State: Shows the current state of the tank refill control.
 - a) Disabled
 - b) Manual Override
 - c) Filling
 - d) Not Full
 - e) Full
5. Liquid Level Status: Shows the state of the liquid level in the tank.
 - a) Below Probe
 - b) OK

- Removal and Replacement:**
1. Disconnect the brewer from the power source.
 2. Disconnect the wire from the level probe.
 3. Lift level probe out of grommet.

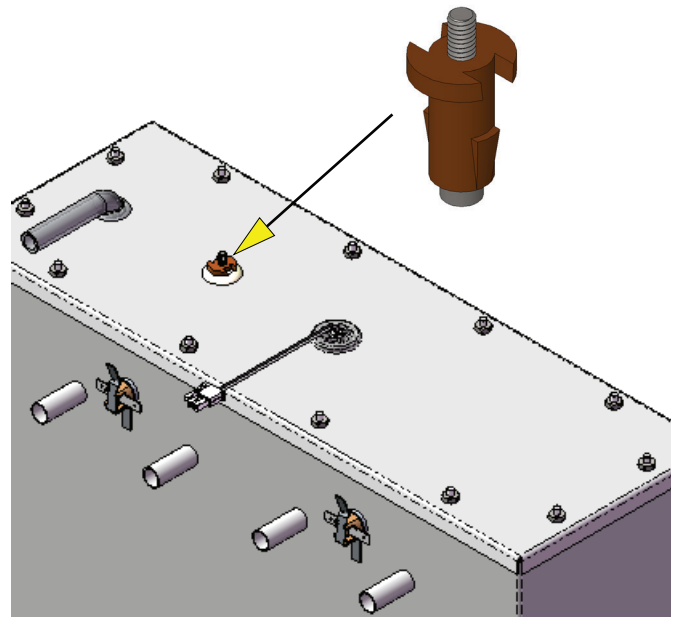

FIG. 34-2 LIQUID LEVEL PROBE

LIQUID LEVEL PROBE DIAGNOSTIC A/D #

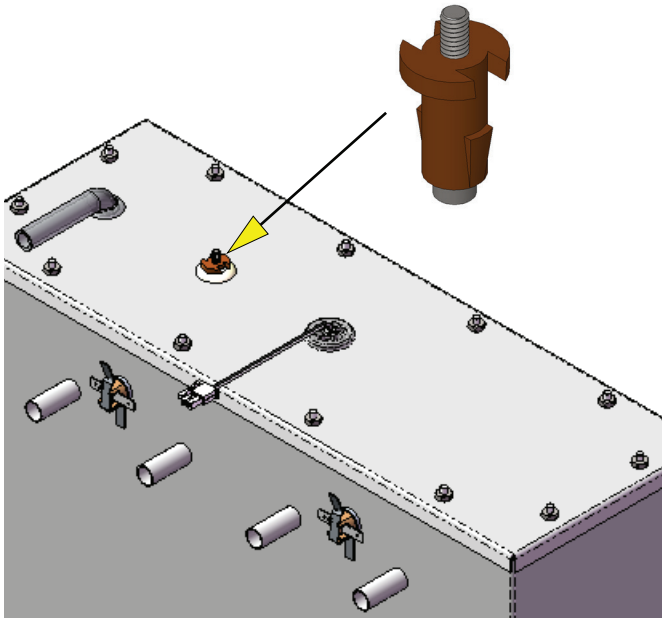

FIG. 35-1 LIQUID LEVEL PROBE

Test Procedure:

The Input/Output Diagnostic screen with the Liquid Level Probe A/D number can be used to view the operation and/or troubleshooting of the level circuit by viewing the A/D number.

1. Go into the software menu and select the "Service" icon and enter Diagnostics menu.
2. Select and touch the I/O Diagnostics button.
3. Use the scroll arrow (upper right corner) to move forward to the next screen.
4. **Liquid Level Probe:** Shows the A/D (analog signal converted to digital format) count of the liquid level probe. (Fig. 35-3 & 35-4)
5. The Factory Refill Threshold A/D default number (155) can be viewed or calibrated by entering the software "Service Icon" and entering the Refill Calibration menu. (Fig. 35-2)
6. A Factory Default Refill Threshold (155) number is the On/Off trigger point for the inlet solenoid valve.
7. Geographically it's rare to have very low water TDS (Total Dissolved Solids) levels which does not require to adjust the brewer "Water Threshold" A/D setting.
8. In the event of low water TDS and/or hinder the operation of the liquid level circuit, the Refill Threshold can be adjusted. See Refill Calibration Procedure.

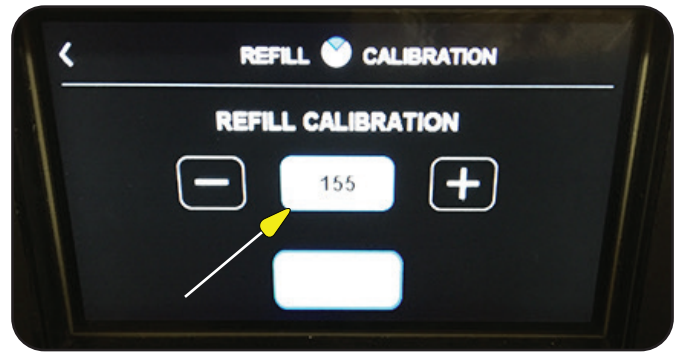

FIG. 35-2 DEFAULT REFILL THRESHOLD #

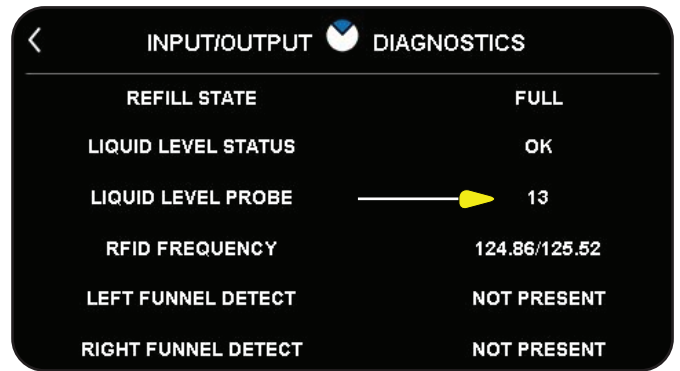

FIG. 35-3 LEVEL PROBE A/D LOW #

Test Procedure:

155 - Factory Refill Threshold #; Trigger On/Off point of inlet solenoid valve.
Liquid Level Probe A/D # under 155 threshold; Level probe circuit is shorted, no activation of inlet solenoid valve.

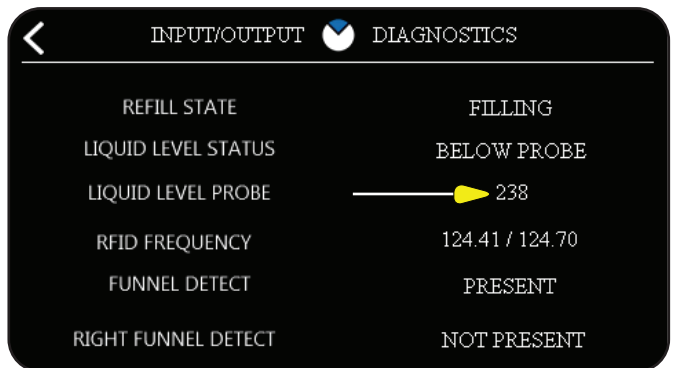

FIG. 35-4 LEVEL PROBE A/D HIGH #

Test Procedure:

155 - Factory Refill Threshold #; Trigger On/Off point of inlet solenoid valve.
Liquid Level Probe A/D # over 155 threshold; Level probe circuit is open, activation of inlet solenoid valve.

LEVEL PROBE/REFILL CALIBRATION



FIG. 36-1 REFILL CALIBRATION

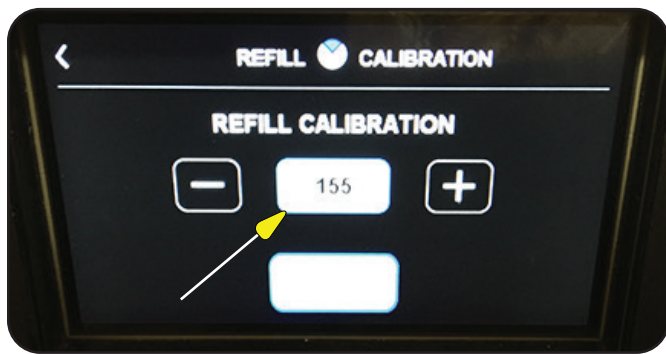

FIG. 36-2 DEFAULT REFILL THRESHOLD #

Location:

The Factory Refill Calibration menu can be accessed by entering the software and selecting the "Service Icon" and then enter the Refill Calibration menu. (Fig. 36-1)

Calibration Procedure:

Procedure for calibrating the Factory Default 155 Threshold A/D number when the water supply or filtered water has a very low Total Dissolved Solids (TDS). (Fig. 36-2)

Water Threshold Operation Range: 0 - 255

Water Threshold Adjustment Range: 20 - 230

Factory Water Threshold Default: 155

1. Go into the software menu and select the "Service" icon and enter Diagnostics menu.
2. Select and touch the I/O Diagnostics button.
3. Use the scroll arrow (upper right corner) to move forward to the next screen.
4. Note the Liquid Level Probe A/D number when water is touching the liquid level probe. A typical A/D reading with average TDS will be around 10 or less.

5. If the A/D number is close or higher than the Factory calibration threshold number of 155, the refill calibration threshold will need to be calibrated/adjusted.
6. You take the actual A/D number (water touching level probe) and subtract it from the maximum threshold number 255.
7. Next, take the difference and divide by 2 and then add that number back onto the actual A/D number (water touching probe).
8. Enter the new A/D number by using the +/- buttons in the Refill Calibration menu.
9. Exit the software menus and go back to Home screen.

Example:

The Liquid Level Probe A/D number displays 80 when water is touching the level probe.

$$255 \text{ minus } 80 = 175$$

$$175 \text{ divide by } 2 = 87.5$$

87.5 add to 80 = 167.5 (round up to 168) A/D number will be the new Refill Calibration Threshold.

Note: Anytime Factory Defaults is restored on the brewer, Refill Calibration Threshold will return to Factory Default of 155.

TOUCH SCREEN CALIBRATION

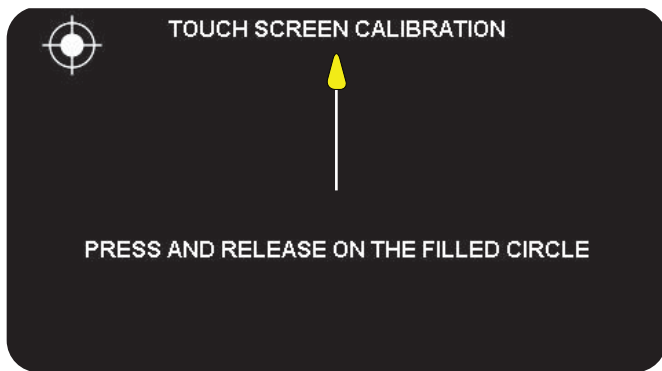

FIG. 37-1 TOUCH SCREEN CALIBRATION

Location:

If the calibration points in NVM are blank, the calibration touch screen will automatically appear. If the calibration points have been set, the touch screen calibration screen can be accessed by pressing and holding anywhere on the splash screen during a power up.

User Symptom/Problem:

In rare cases the screen may be slightly out of calibration. The complaint might be "doesn't respond well when pressing recipes, batch sizes, brew or entering software menus".

Calibration Procedure:

Procedure for calibrating the user touch screen.

1. Access touch screen calibration menu by pressing and holding anywhere on the splash screen during a brewer power up.
2. When the touch screen calibration screen is shown, precisely touch each of the four targets (filled circles) as they appear on the screen. (Fig. 37-2)
3. Once all four target points have been touched, the calibration points will be saved into non-volatile memory (NVM).
4. Exit calibration screen by pressing and holding on the splash screen.

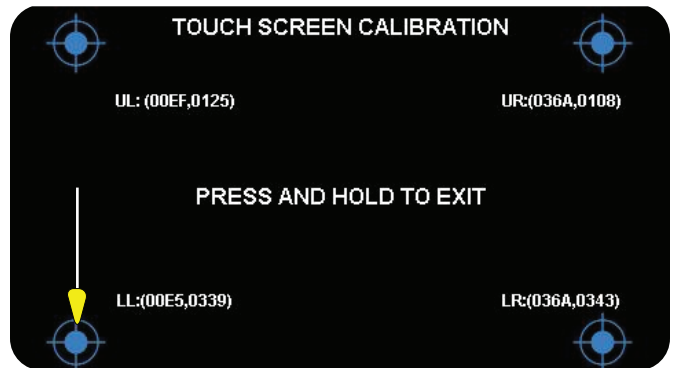
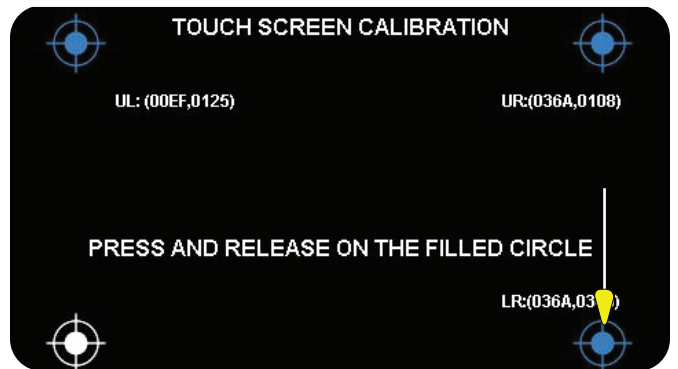
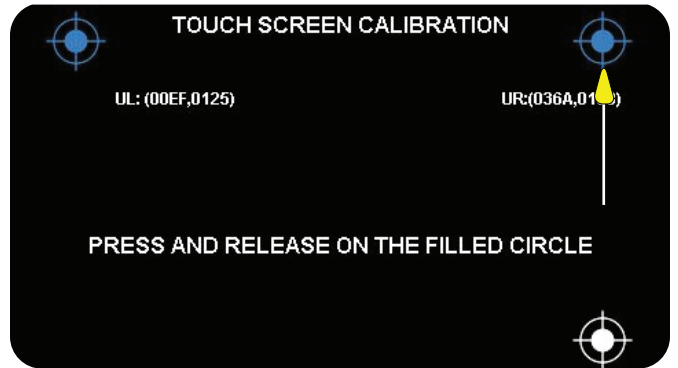
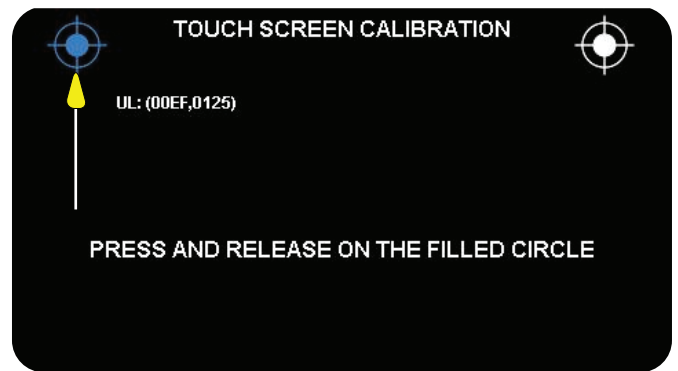

FIG. 37-2 CALIBRATION TARGETS

PLATINUM EDITION

PLATINUM EDITION ERROR/WARNING MESSAGES

The below list is an explanation and parameters for triggering an Error Message and their Possible Causes.

1. **Error Message “Heating Time Too Long”** – Heater on continuously greater than (>) 60 minutes.
Powering machine down or refill valve turns on will reset the 60 minute timer.

Possible Cause(s): Tank Heater, Limit Thermostat, Triac or CBA/Temperature Sensor failure.

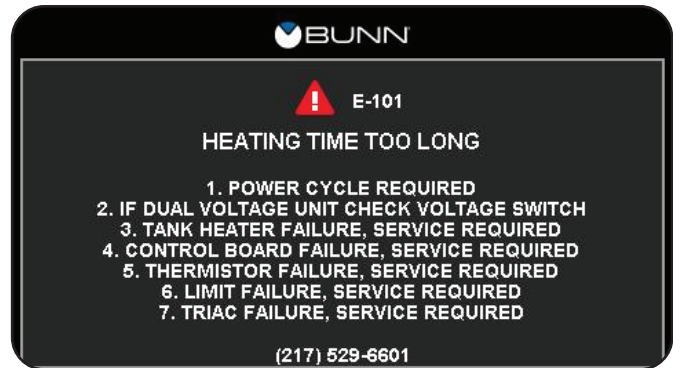

2. **Error Message “Fill Time Too Long”** -- Refill on greater than (>) 30 minutes.

Possible Cause(s): Main water supply is turned Off, Water Solenoid failure, debris blocking or restricting water flow through the .500 flow control assembly, main control board voltage Output failure.

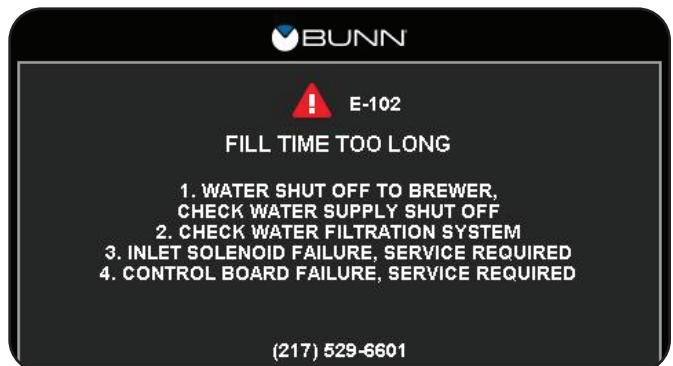

3. **Error Message “Temp Sensor Out Of Range, Check For Bad Connections”** – Temperature less than (<) 32° Fahrenheit.

Possible Cause(s): Temperature sensor failure or poor temperature sensor connection at the control board connector or temperature sensor wiring harness connector itself.

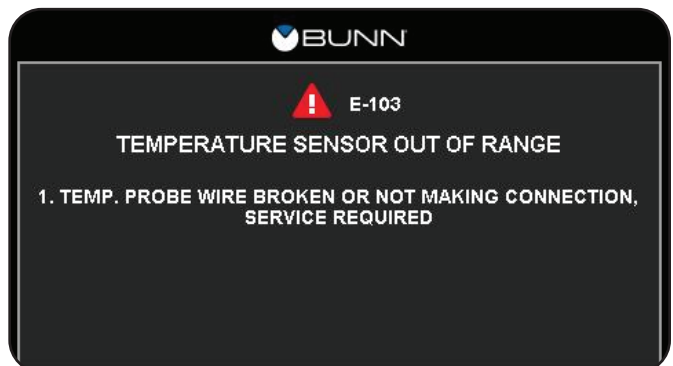

PLATINUM EDITION ERROR/WARNING MESSAGES

The below list is an explanation and parameters for triggering an Error Message and their Possible Causes.

- 4. **Error Message “Temp Sensor Out Of Range, Check Wire For Shorts”** -Temperature greater than (>) 230° Fahrenheit.

Possible Cause(s): Temperature sensor failure or temperature sensor wires are pinched between two surfaces or connected to each other.



- 5. **Error Message “I/O Board Not Detected”** – The board is not receiving the proper commands or a loss of communication occurs.

Possible Cause(s): The TX or RX wires between the I/O board and the Touch Screen (PLC) assembly may have an intermittent or open connection

Display Board: J10-4
J10-1 - Red Wire, Receiving (RX)
J10-2 - Blue Wire (Negative)
J10-3 - White Wire Transmission (TX)
J10-4 - Green Wire (Positive)

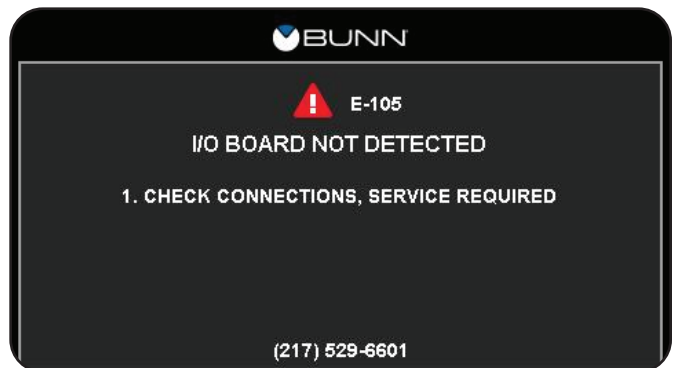

- 6. **Error Message “PLC Board Not Detected”** – The board is not receiving the power supply.

Possible Cause(s): The power wires between the I/O board and the Touch Screen (PLC) assembly may have an intermittent or open connection. Power supply to the PLC is 13.8VDC to 15.0VDC.



PLATINUM EDITION PLATINUM EDITION ERROR/WARNING MESSAGES

The below list is an explanation and parameters for triggering an Error Message and their Possible Causes.

- Warning Message “Software Upgrade Needed, Please Reprogram”**- In certain use cases, one board on the machine was upgraded while another board was not. If this happens and the software on the machine is out of date, a pop up will appear to let the user know a software upgrade is needed. The machine will have the ability to show what software needs to be updated which will be communicated on the screen. In some instances you may have two boards that need to be upgraded. If this happens each piece that needs to be upgraded will display it's own error message. This message will not impede brewing or any other functions of the machine. Pressing ok will clear the message for continued use. The message will only be permanently cleared once the software has been upgraded. In the case the user clears the message and does not complete any action on the machine, the alert will display after 3 minutes.

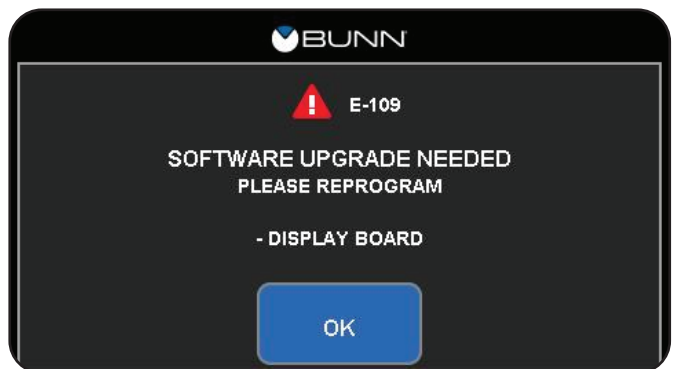
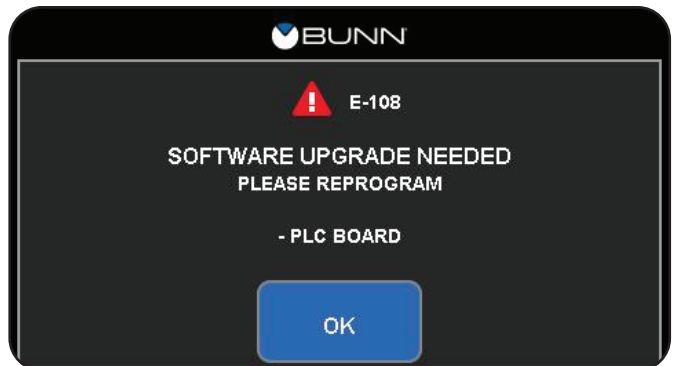
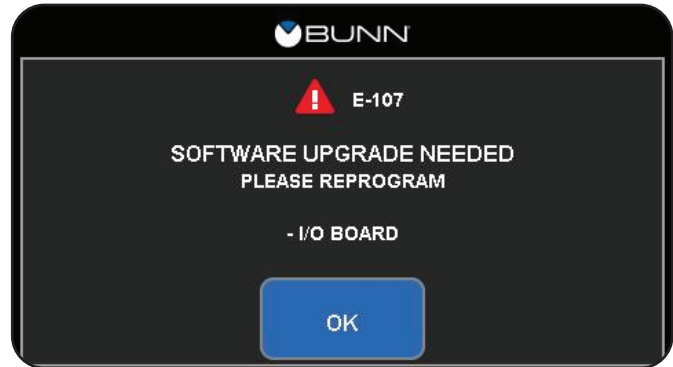

IMPORTANCE OF CALIBRATING BREWER FLOW RATES

Brewer “Calibrate Flow” menu gives you the capability to verify and adjust brewer dispense flow rates to achieve accurate and optimum recipe volumes and flavor profile. The water flow rate deliverable calibration menus found in Infusion Series brewers are sprayhead, by-pass and dilution.

Brewer Water Flow Fundamentals

The understanding of maintaining cleanliness, maintenance and calibration will address a wide variety of issues that can affect brewer flow rate deliverances and flavor profile.

- **Component Tolerances:** Most components have a small amount of tolerance from the start and can degrade over time due to life cycles, neglect or mineral deposit build-up.
- **Low Water Pressure:** Some DBC brewers have a feature where the brew will pause during a brew. The brewer refill cycle must maintain fullness of water at level probe within certain amount of time to maintain a certain amount of weight above the dispense valve for water flow accuracy. If the level probe is dry too long during a brew cycle, the DBC brewer will pause the brew cycle and wait until level probe sees water again before continuing on with original brew cycle. This could have an effect on flavor profile because of starting and stopping of the brew cycle for that particular recipe.
- **Hard Water:** High water grain hardness can affect flavor profile and brewer performance. The accumulative of mineral deposit narrowing the dispense path over coffee/tea funnel will greatly affect recipe volumes and flavor profile.
- **Water Density:** The density of water is the weight of the water per its unit volume, which depends on the temperature of the water. Ambient water temperature verses 200° F. water temperature correlates to approximately 4 % expansion of water. Ambient water will be lesser volume and 200°F. will be more volume. BUNN suggests for optimum performance to calibrate the water flow when the water is at least a minimum of 190° F. and up.
- **Tank Pressure:** All of BUNN tanks are ventilated to the atmosphere which correlates to a conventional unit of pressure, the normal pressure of the air at sea level, about 14.7 pounds per square inch. Anytime the tank ventilation becomes restricted or blocked, the tank pressure will alter the dispense flow rate out the dispense path which will result inaccurate recipe volumes and affect flavor profile.
- **Cleanliness:** A build-up of mineral deposits or coffee oils in the sprayhead holes will restrict water flow and impact brewing profile. Sprayhead panel must be kept clean on a daily basis to prevent unwanted impurities being added to a fresh brew. By performing the daily clean task, you will help ensure the quality of the brewed profile.

Reason/Conditions to Perform Brewer Water Flow Rate Calibration

- New install/set-up, final placement or relocation of brewer.
- Short filling of recipe volumes (mineral deposit build-up).
- Change or alteration of number hole sprayhead for recipe flavor profile.
- During scheduled preventive maintenance tasks.
- After a general brewer water related service repair.

WATER FLOW CALIBRATION MENUS

The machine calibration menus are essential to brewer functionality and can be used as a testing tool for checking water flow rates out the sprayhead, by-pass and/or dilution nozzle. The collected volume during test can show if you have a flow restriction somewhere in the hot water tank output dispense path or too much output water flow in a minutes time. The collected volume during dilution flow test can show if you have low or high incoming water pressure and/or flow restriction to the brewer dilution nozzle. By performing the 60 second flow test and entering the delivered volume for each left and right sprayhead, by-pass and/or dilute valve will assure the accuracy in the related recipe total volume and flavor profile.

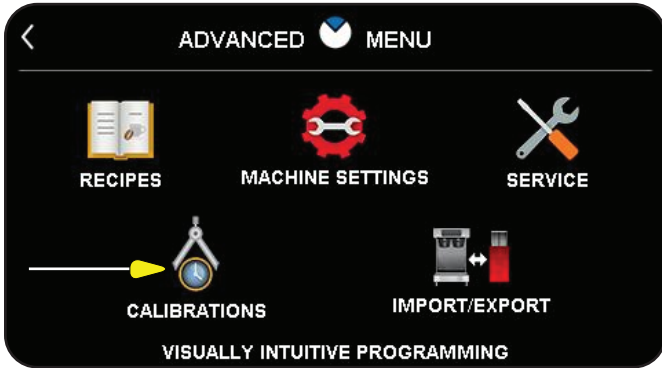

FIG. 38-1 ADVANCED MENU

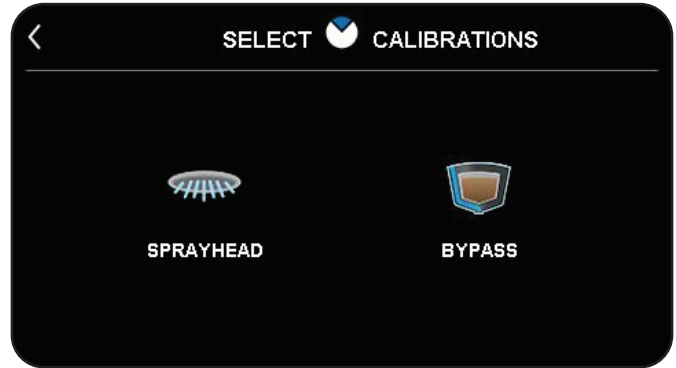

FIG. 38-2 ICB

Location:

Enter Service Access screen and select Advanced Icon, plus passcode. From the Advanced Menu select Calibrations icon.

Calibration Flow Menus:

A specific calibration menu may be found among brewer models which will be used to calibrate the flow rates of the sprayheads, bypass valves, and/or dilution valves.

1. Infusion Series Coffee Brewers. (Fig. 38-2)
2. Infusion Series Tea Brewers. (Fig. 38-3)
3. Infusion Series Coffee & Tea Brewer. (Fig. 38-4)

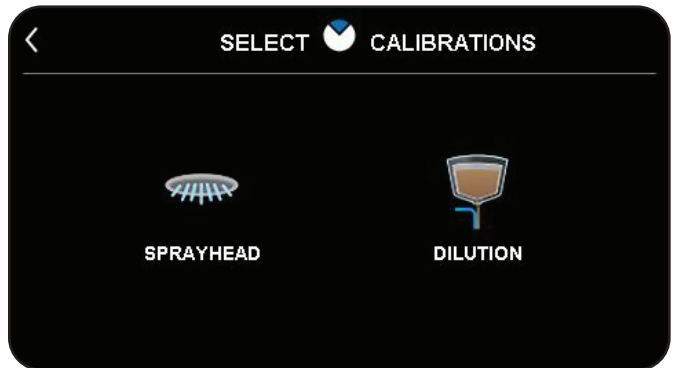

FIG. 38-3 ITB

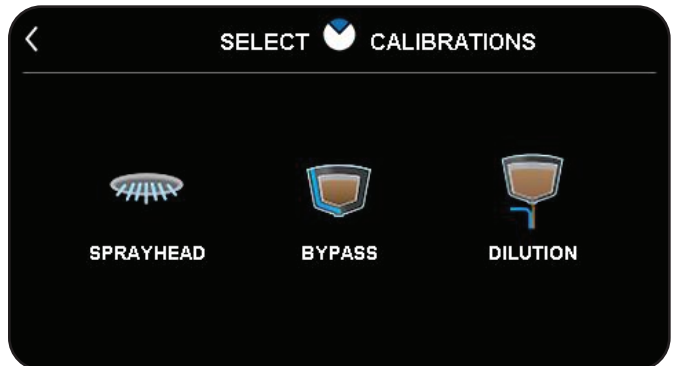

FIG. 38-4 ITCB

WATER FLOW CALIBRATION STEPS

The sprayhead instruction demonstrates the steps on performing the calibration. The Bypass and Dilution calibration process performs the same way other than dilution calibration will deliver larger amount of water which requires a larger vessel to capture the volume.

1. The Sprayhead Icon will be used to calibrate the flow from the sprayhead. Sprayhead and Bypass can only be calibrated when the tank has reached the ready or set temperature. This will ensure that the calibrations are accurate and reflect the machine at its brewing temperature.

2. For Single ICB models, there is only 1 sprayhead to calibrate. For Twin ICB models, there is a left and a right sprayhead to calibrate. Ensure the container is under the correct sprayhead for calibration. Select the START button to begin a 1-minute dispense of hot water from the sprayhead.

3. The display will show the time remaining for dispense along with the option to stop the dispense if necessary. The 60-second timer on the display will count down to zero.

4. When the counter reaches zero, the display will change to allow the measured amount of water in the container to be entered and saved in programming. Use the +/- buttons to increment the flow number to the measured amount of water produced from 60 second dispense test.

5. Once the flow number has been set, touch the SAVE button. The display should now show the actual flow rate of the sprayhead.

6. When you perform Bypass or Dilution calibration, each step is mirrored like the sprayhead calibration.

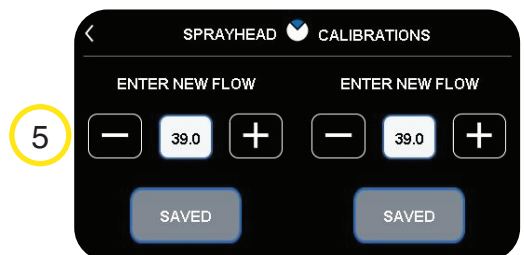
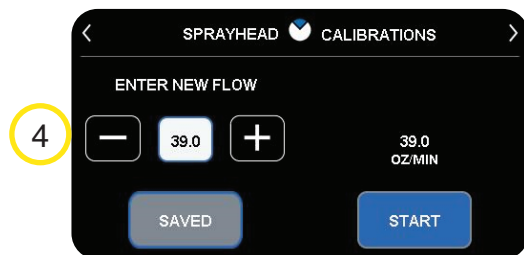
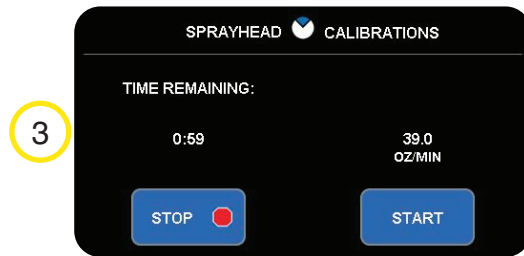
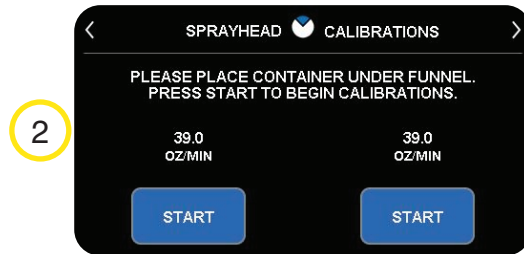
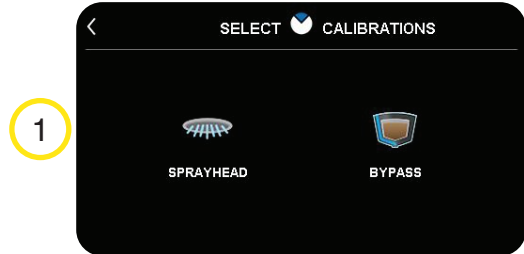
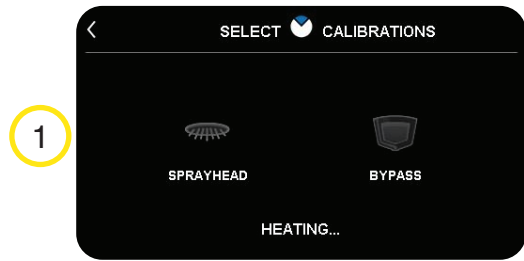

SCHEMATIC WIRING DIAGRAM ITCB-DV

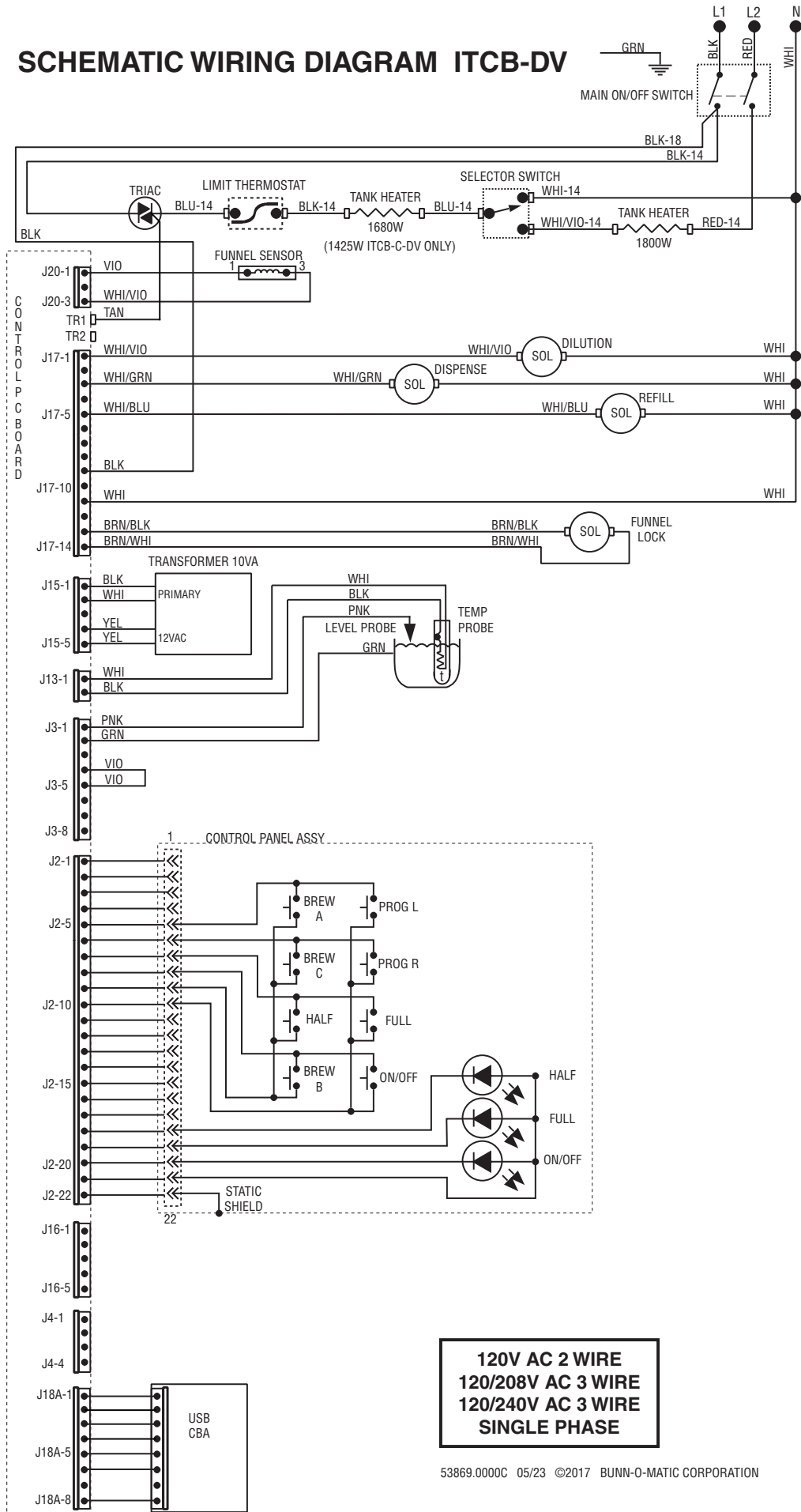

**120V AC 2 WIRE
120/208V AC 3 WIRE
120/240V AC 3 WIRE
SINGLE PHASE**

53869.0000C 05/23 ©2017 BUNN-O-MATIC CORPORATION

SCHEMATIC WIRING DIAGRAM ITCB-A,B&CE w/TRIACS

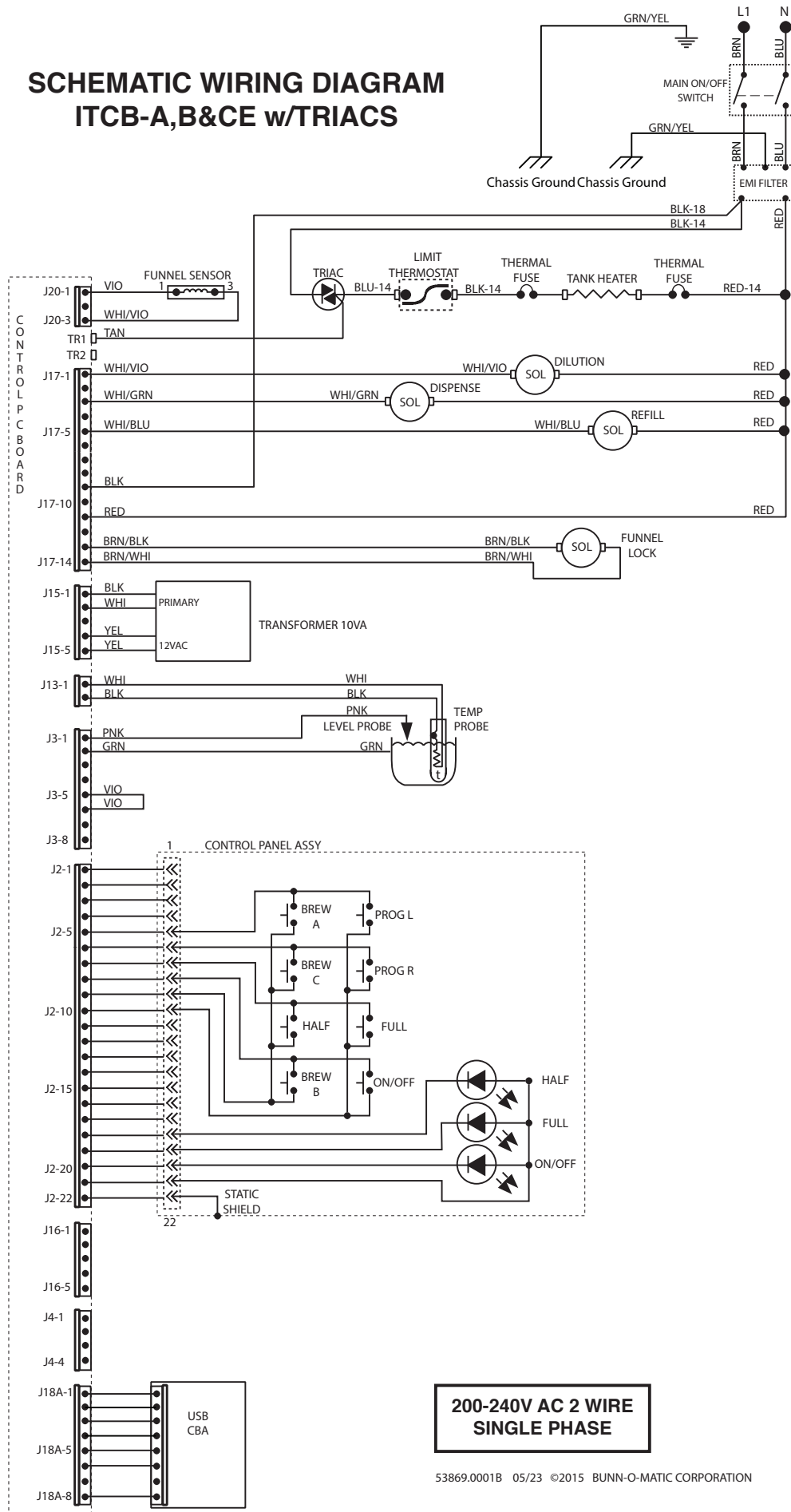

**200-240V AC 2 WIRE
SINGLE PHASE**

53869.0001B 05/23 ©2015 BUNN-O-MATIC CORPORATION

SCHEMATIC WIRING DIAGRAM ICB-DV

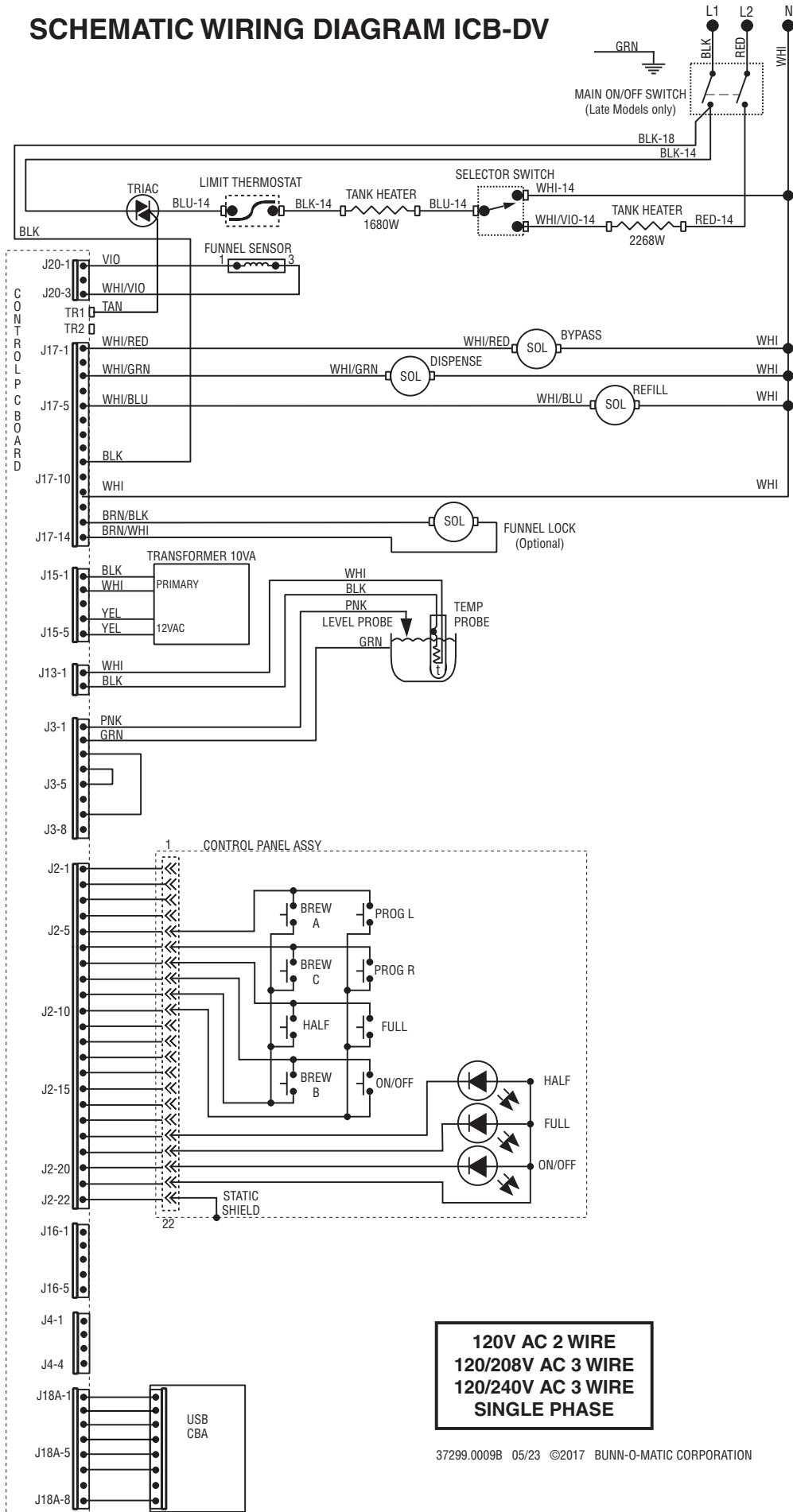

**120V AC 2 WIRE
120/208V AC 3 WIRE
120/240V AC 3 WIRE
SINGLE PHASE**

37299.0009B 05/23 ©2017 BUNN-O-MATIC CORPORATION

SCHEMATIC WIRING DIAGRAM ICB TWIN

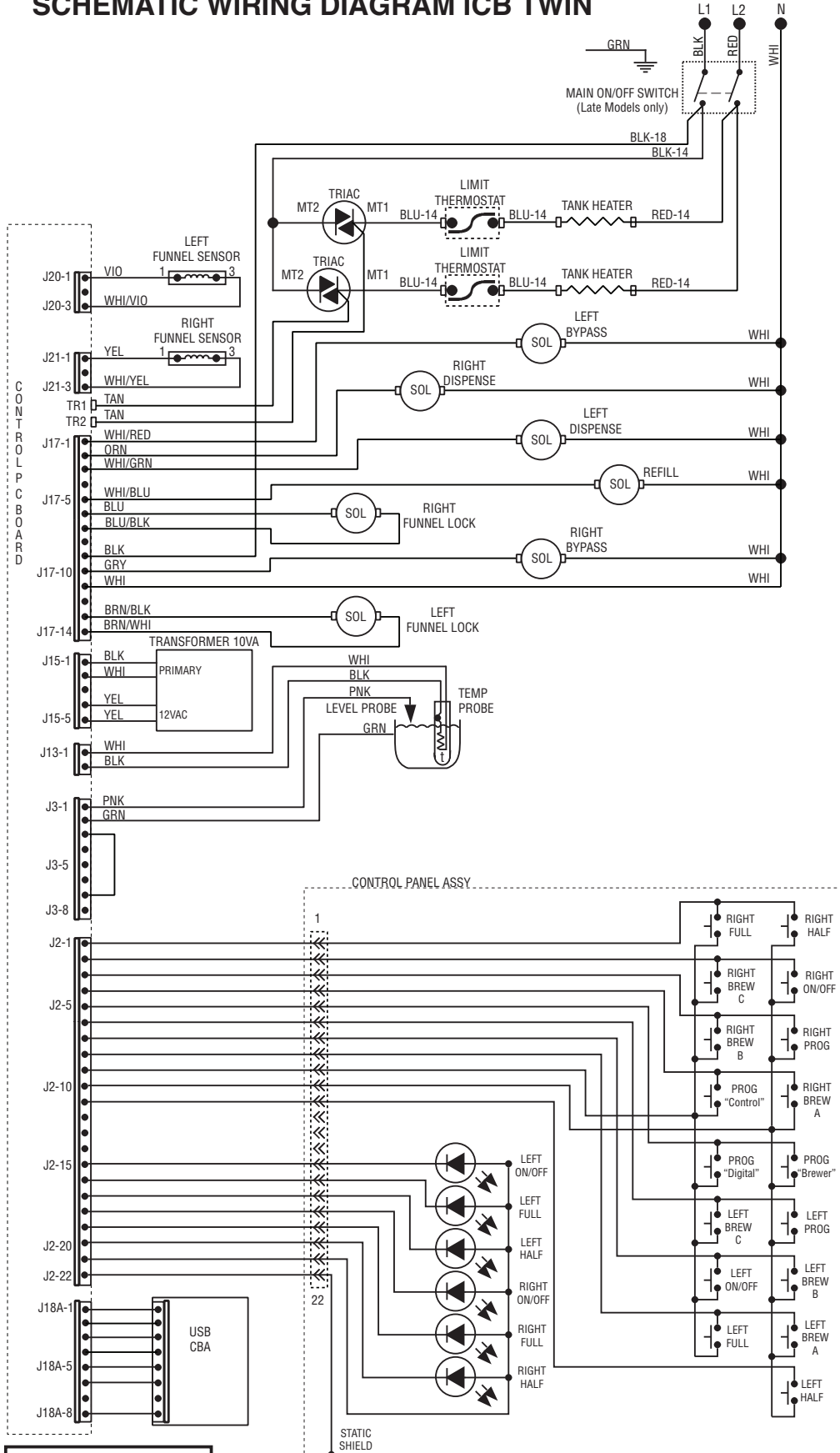

**120/208 OR 120/240
VOLTS AC
3 WIRE + GND
SINGLE PHASE**

SCHEMATIC WIRING DIAGRAM ICBA, ICBB & CE w/TRIACS

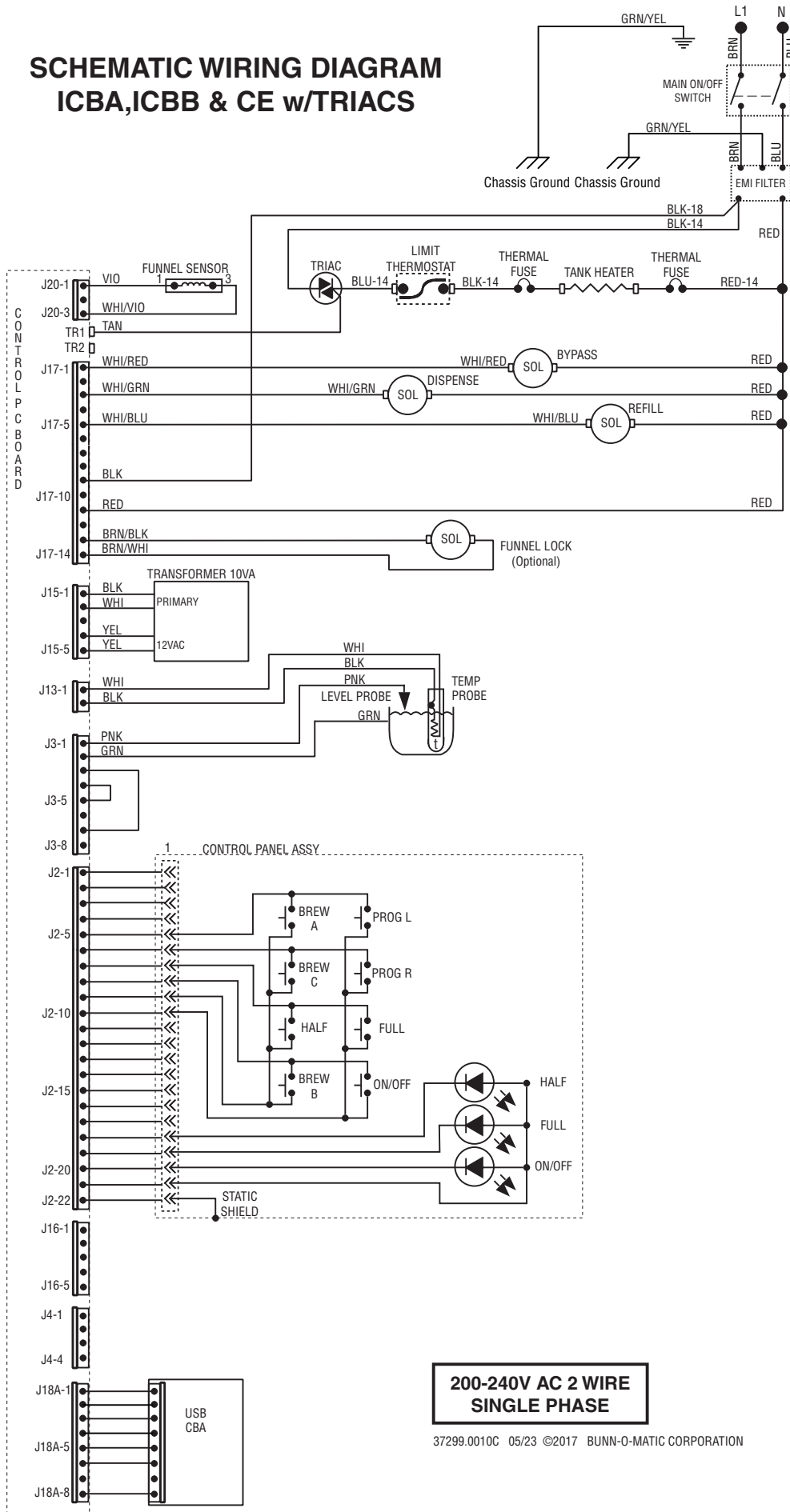

SCHEMATIC WIRING DIAGRAM ITCB HV TWIN

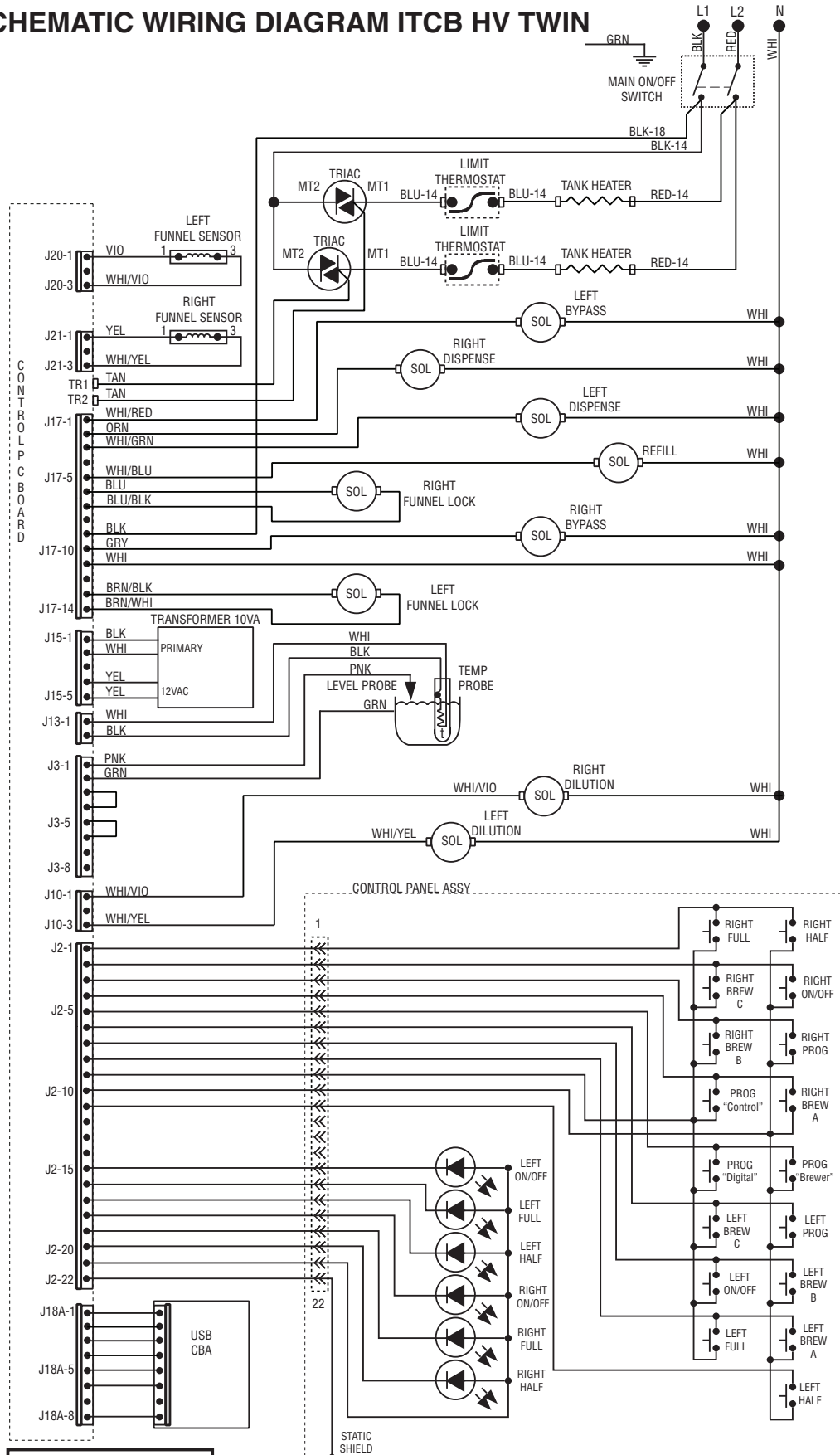

**120/208 OR 120/240
VOLTS AC
3 WIRE + GND
SINGLE PHASE**

SCHEMATIC WIRING DIAGRAM ITB

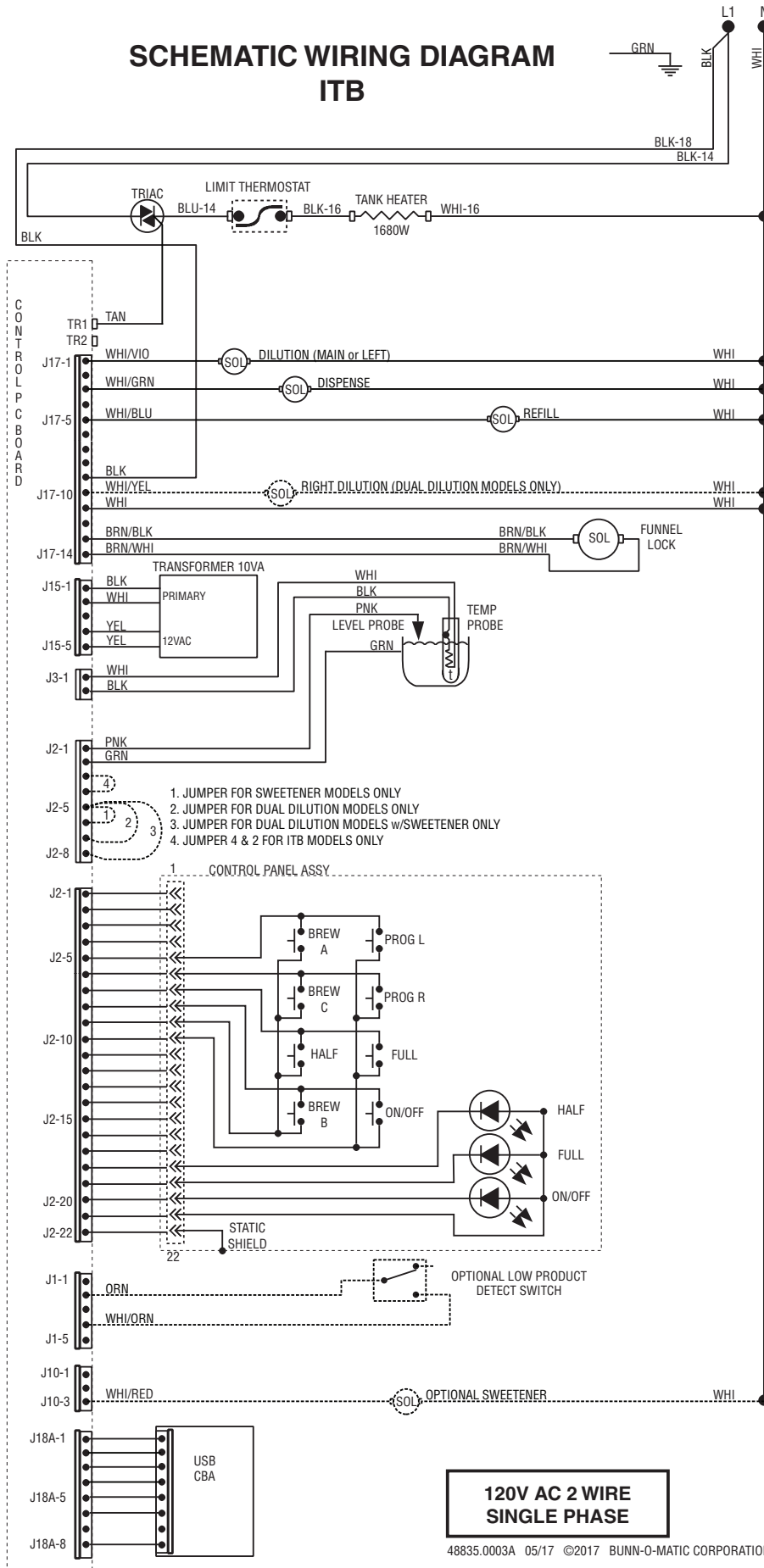

SCHEMATIC WIRING DIAGRAM ITCB-DV HV

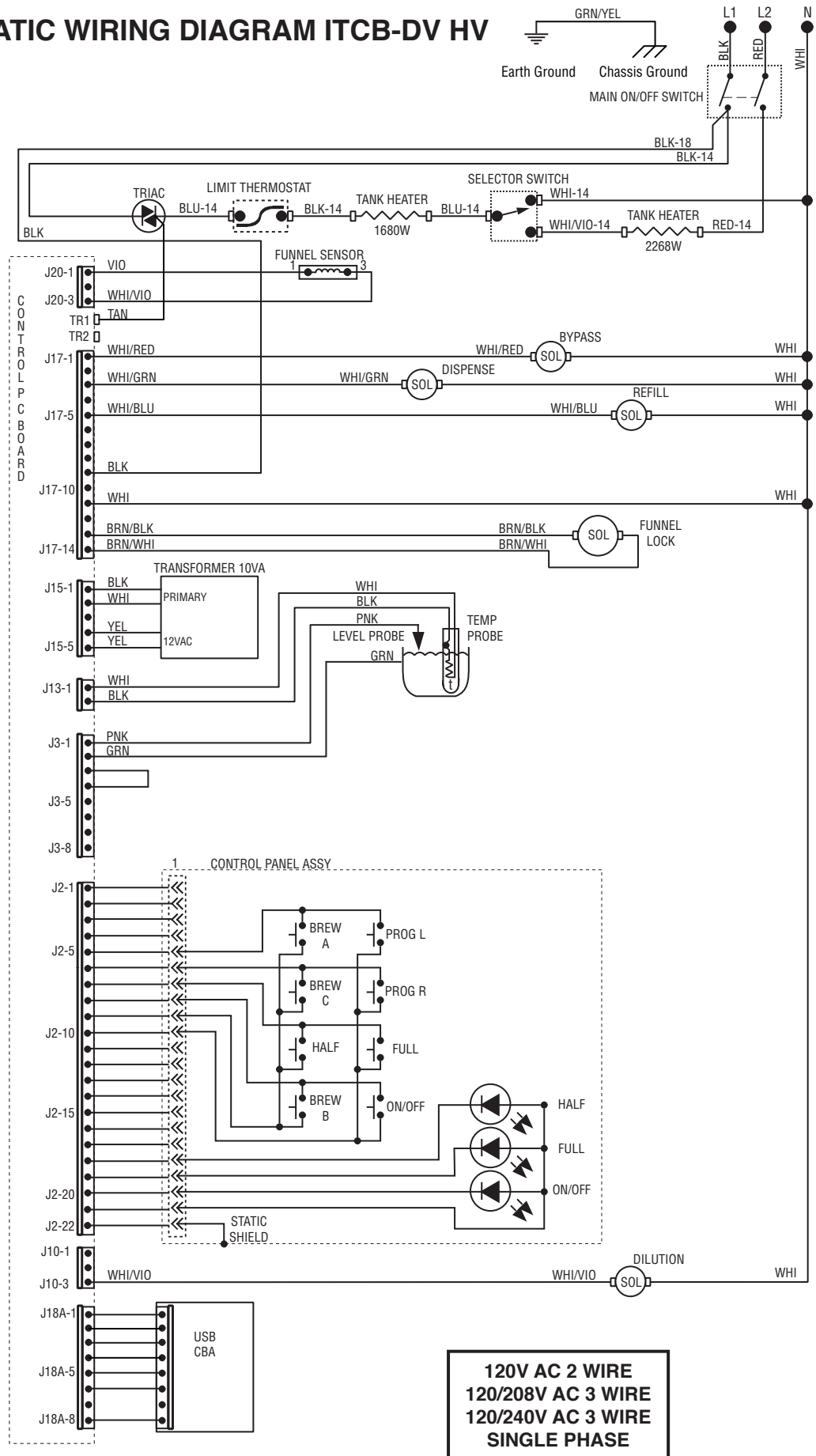

**120V AC 2 WIRE
120/208V AC 3 WIRE
120/240V AC 3 WIRE
SINGLE PHASE**

SCHEMATIC WIRING DIAGRAM ITCBA HV

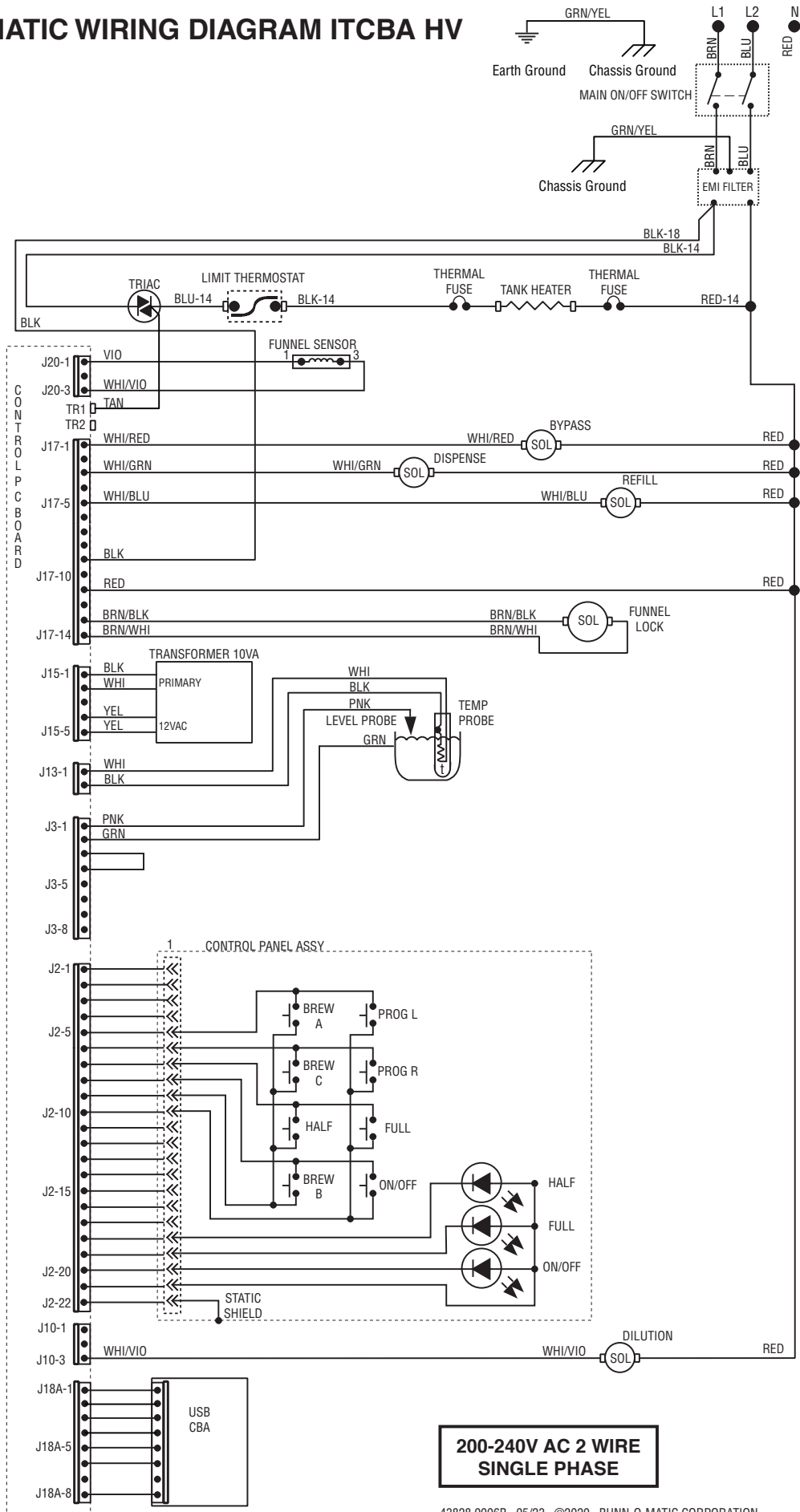

**200-240V AC 2 WIRE
SINGLE PHASE**

SCHEMATIC WIRING DIAGRAM ITBA-DUAL DILUTION/SWEETENER

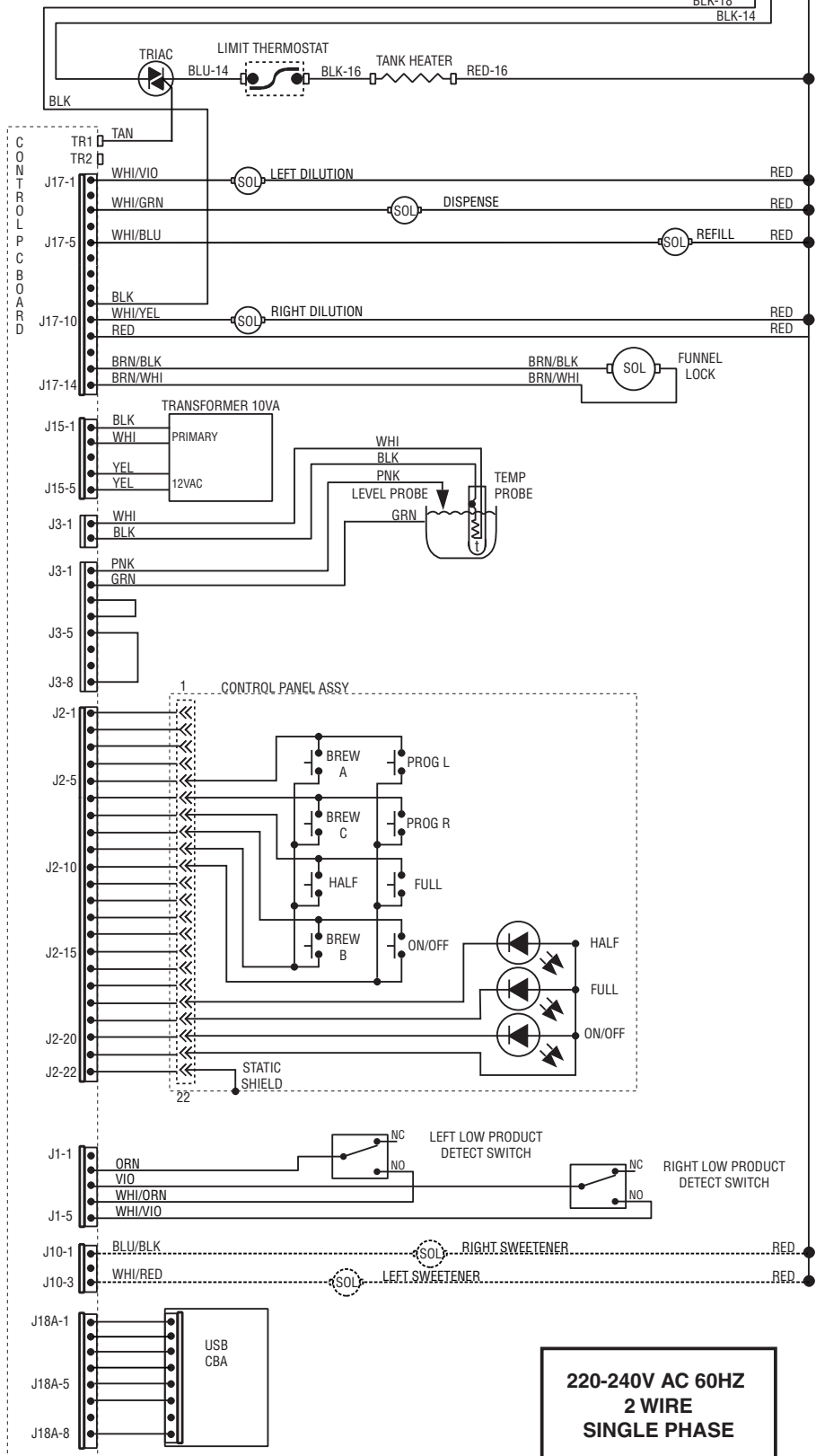
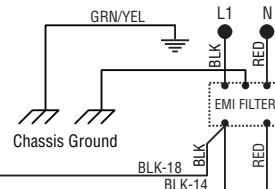

**220-240V AC 60HZ
2 WIRE
SINGLE PHASE**

SCHEMATIC WIRING DIAGRAM ICB SH

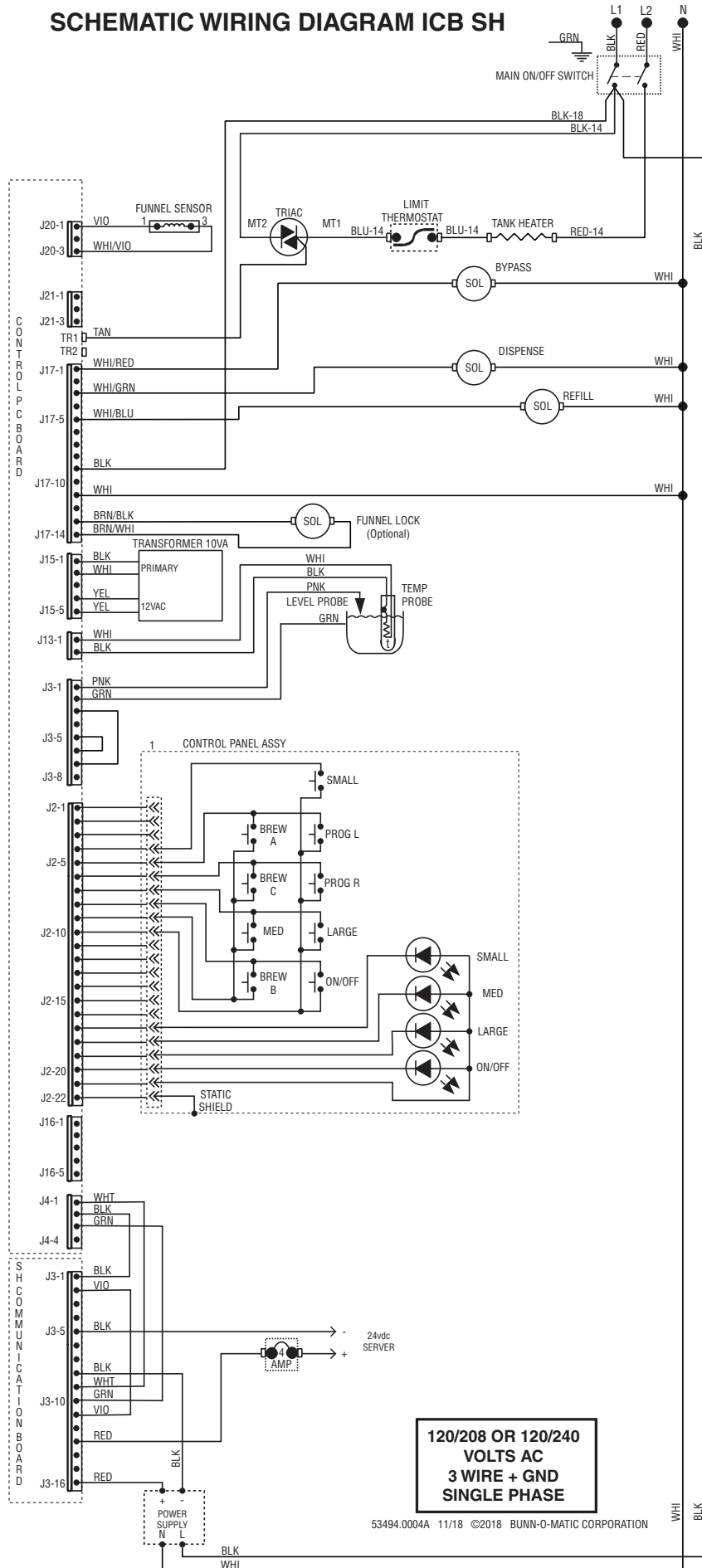

**120/208 OR 120/240
VOLTS AC
3 WIRE + GND
SINGLE PHASE**

53494.0004A 11/18 ©2018 BUNN-O-MATIC CORPORATION

SCHEMATIC WIRING DIAGRAM ICBA SH

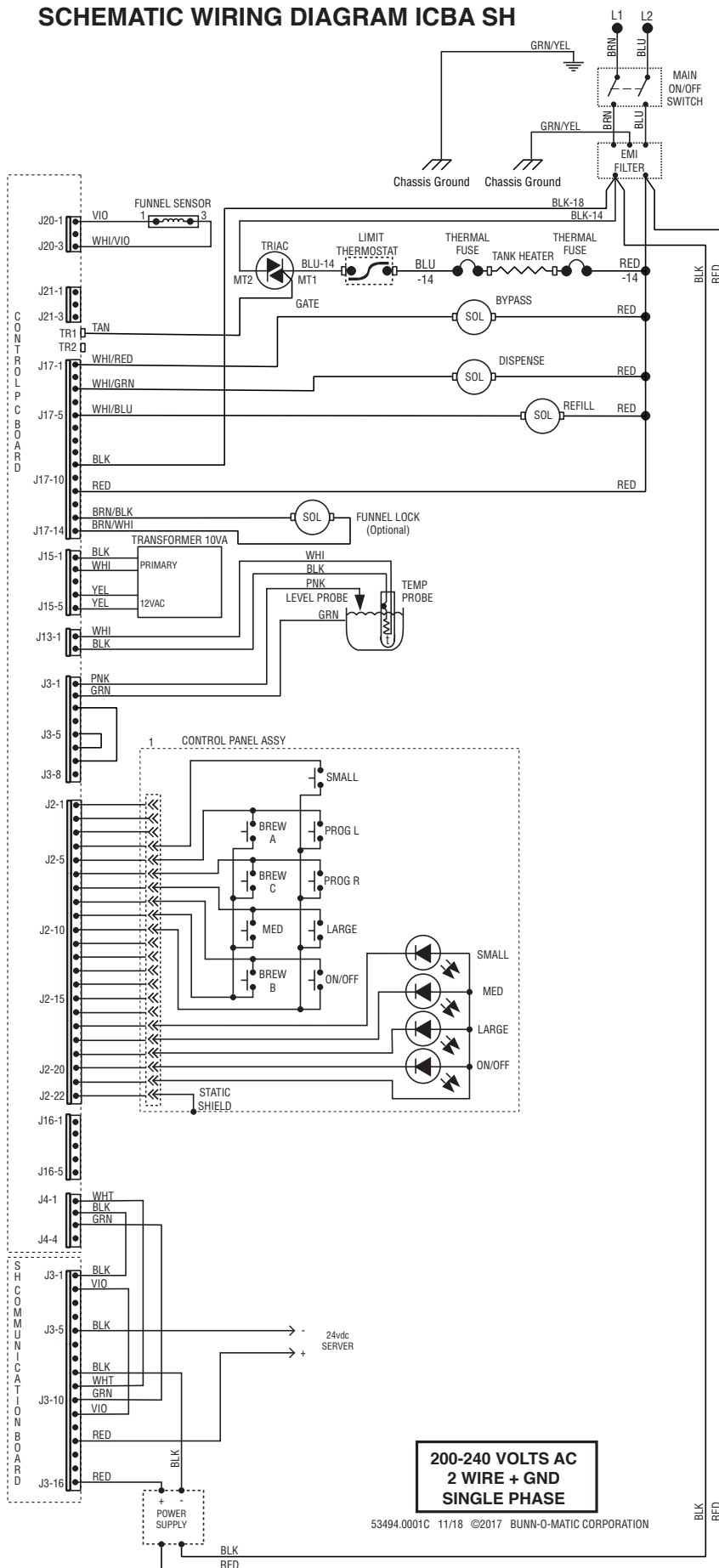

SCHEMATIC WIRING DIAGRAM ICB SH DV

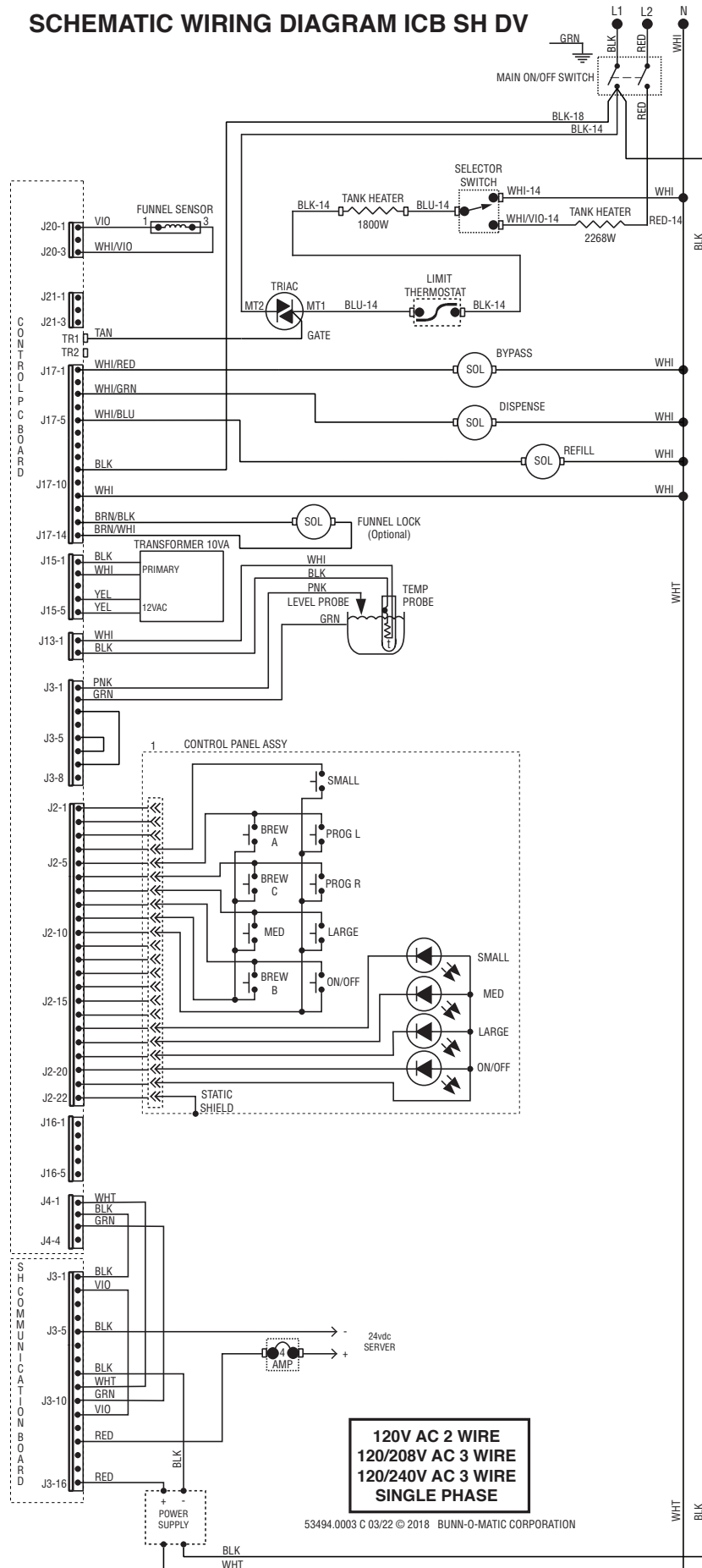

**120V AC 2 WIRE
120/208V AC 3 WIRE
120/240V AC 3 WIRE
SINGLE PHASE**

53494.0003 C 03/22 © 2018 BUNN-O-MATIC CORPORATION

PLATINUM EDITION (220-240VAC)

SCHEMATIC WIRING DIAGRAM ICBA PE CE

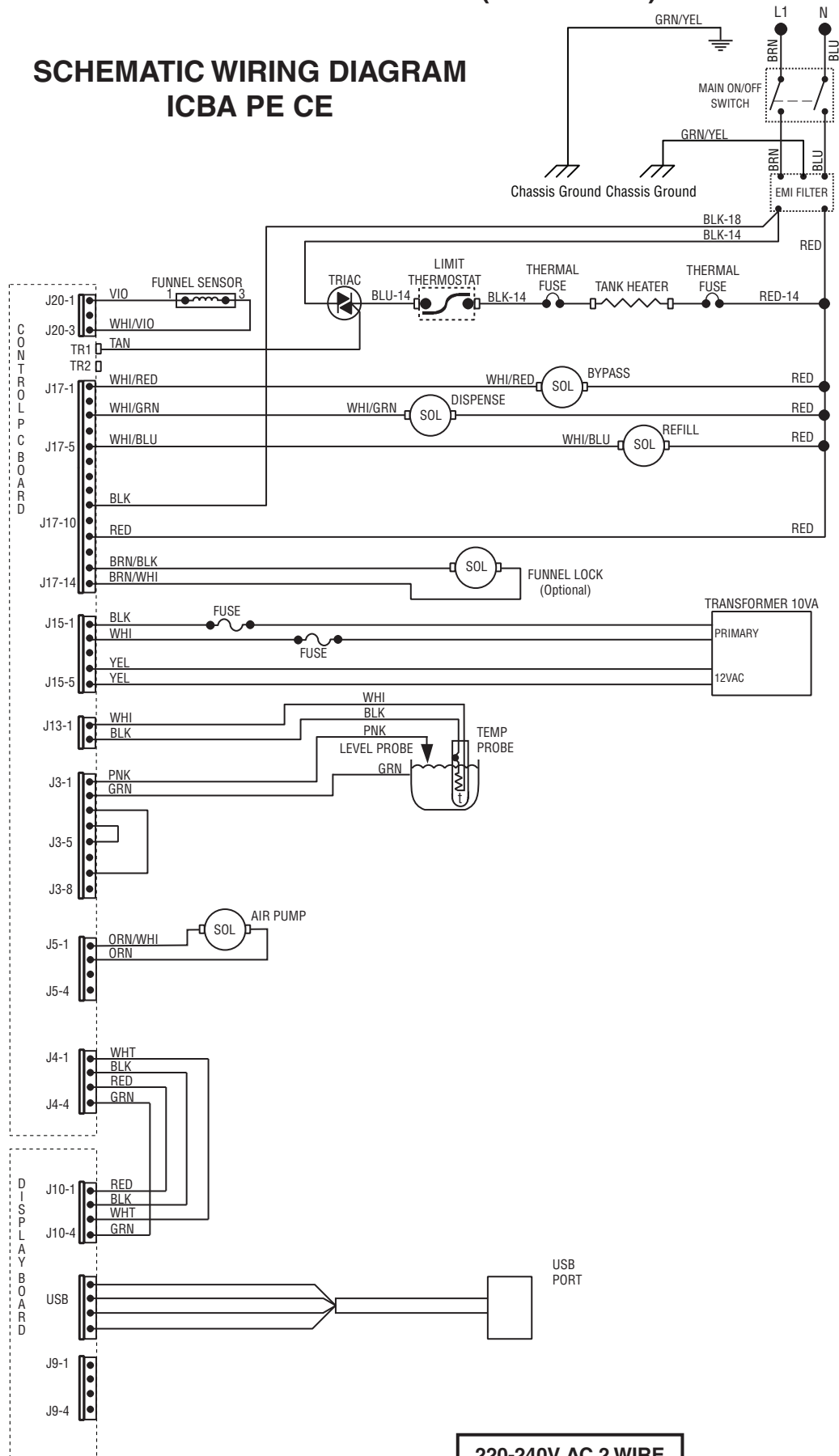

**220-240V AC 2 WIRE
SINGLE PHASE CE**

37299.0014B 05/23 ©2019 BUNN-O-MATIC CORPORATION

PLATINUM EDITION (120V/208-240V)

SCHEMATIC WIRING DIAGRAM ICB-DV PE

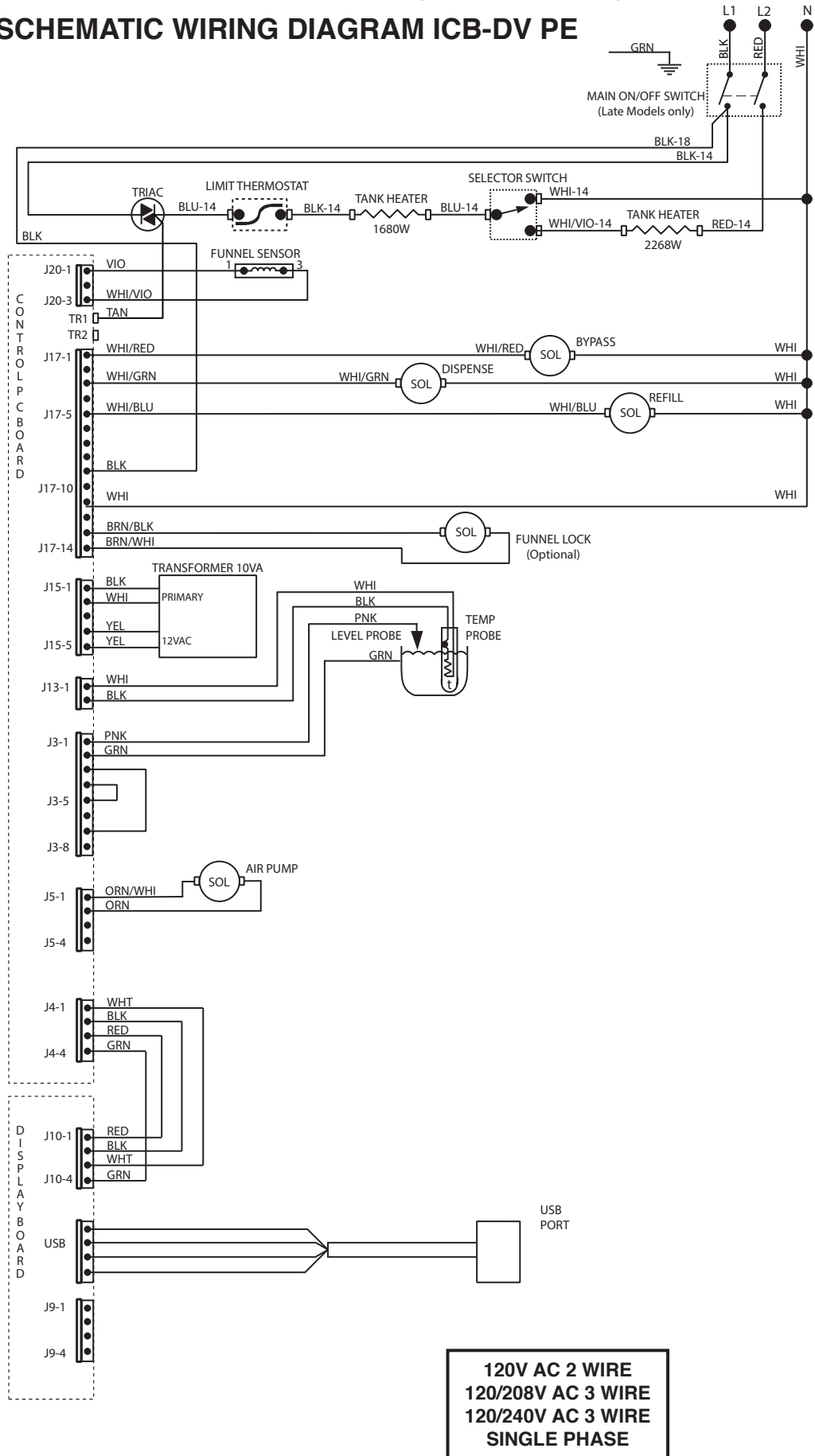

PLATINUM EDITION (120V/208-240V)

SCHEMATIC WIRING DIAGRAM ICB SH PE

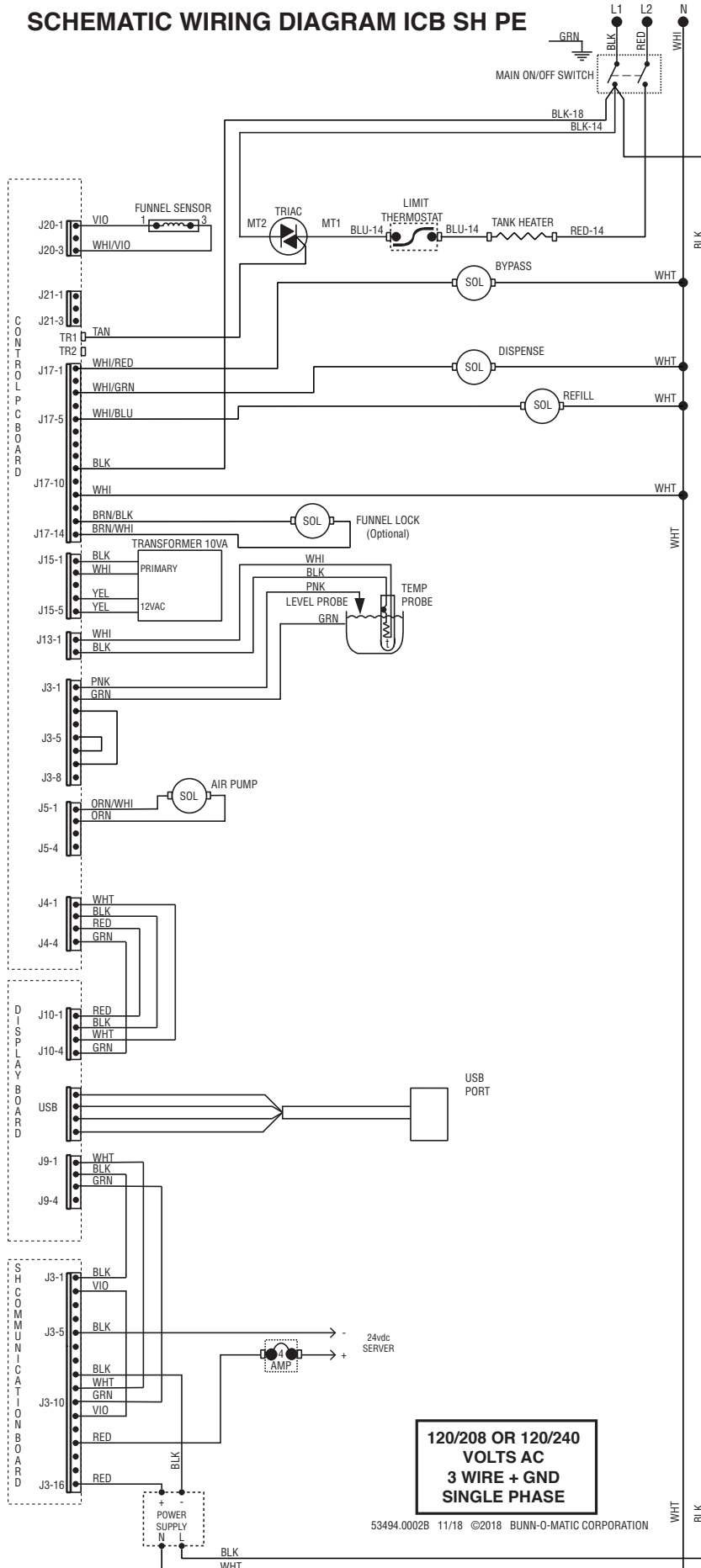

PLATINUM EDITION (120V/208-240V)

SCHEMATIC WIRING DIAGRAM ICB TF PE

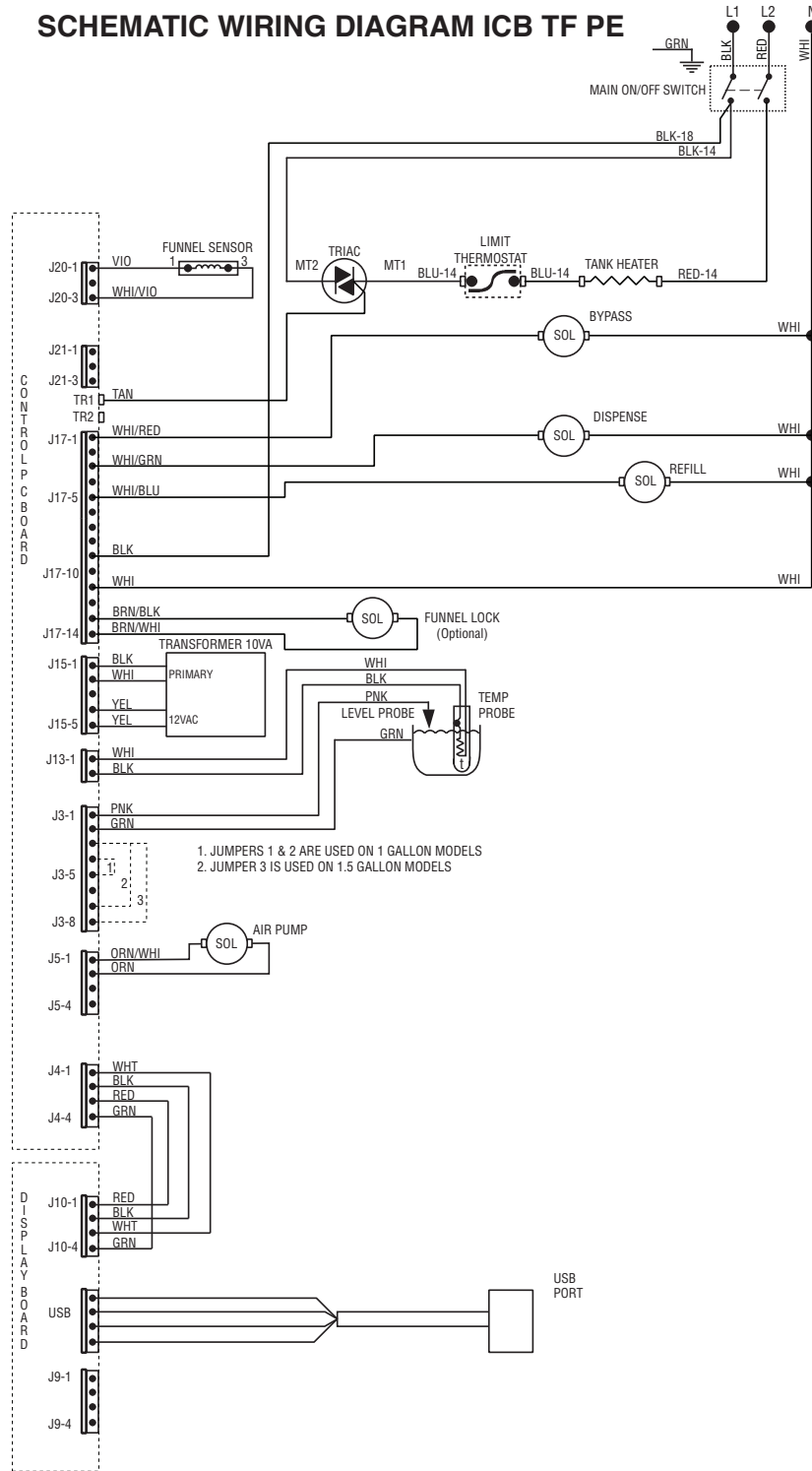

**120/208 OR 120/240
VOLTS AC
3 WIRE + GND
SINGLE PHASE**

55021.0000A 01/18 ©2018 BUNN-O-MATIC CORPORATION

PLATINUM EDITION (200VAC)

SCHEMATIC WIRING DIAGRAM ICB SH 200V

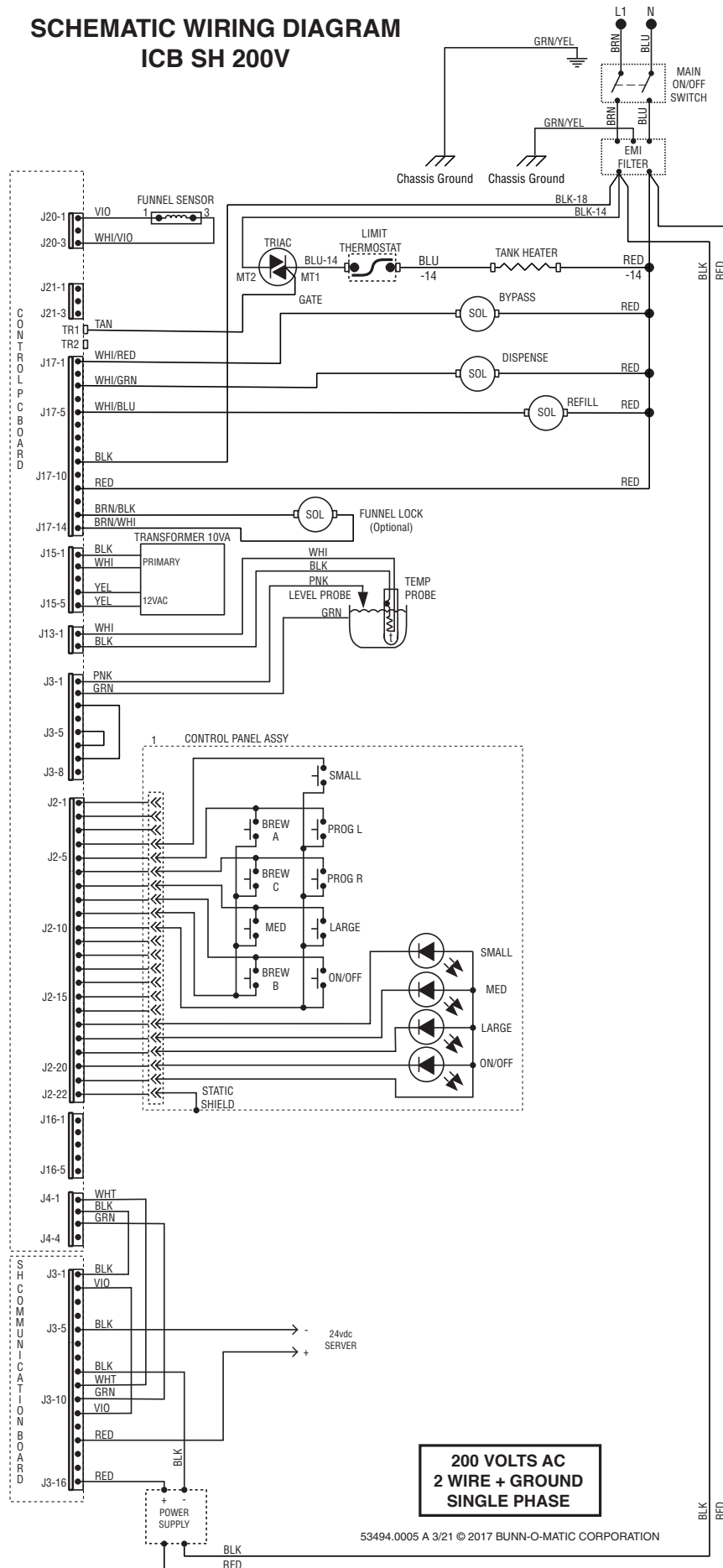

PLATINUM EDITION (200VAC)

SCHEMATIC WIRING DIAGRAM ICB TF PE

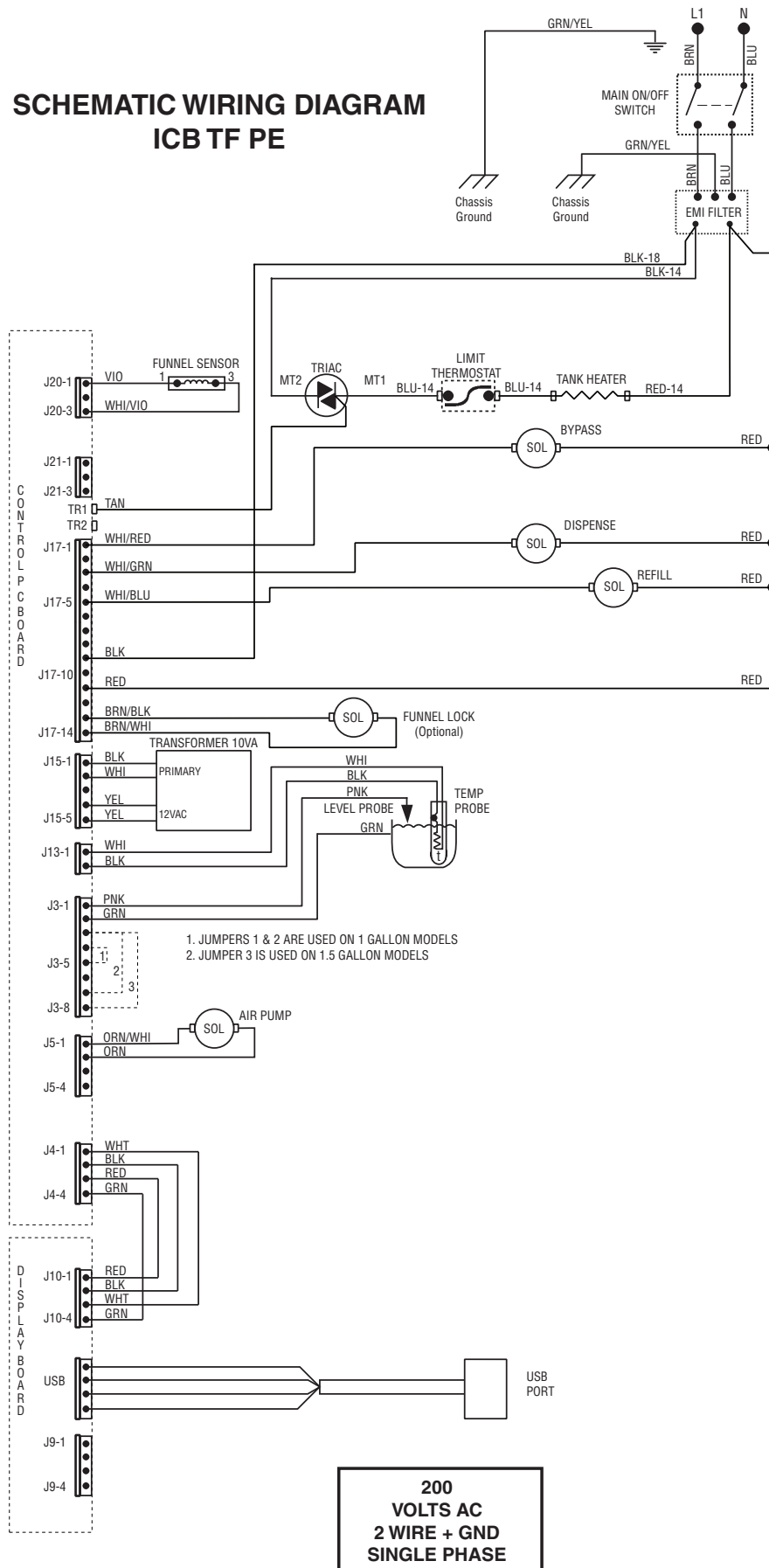

PLATINUM EDITION (120V/208-240V)

SCHEMATIC WIRING DIAGRAM ICB TWIN & ICB TWIN TF PE

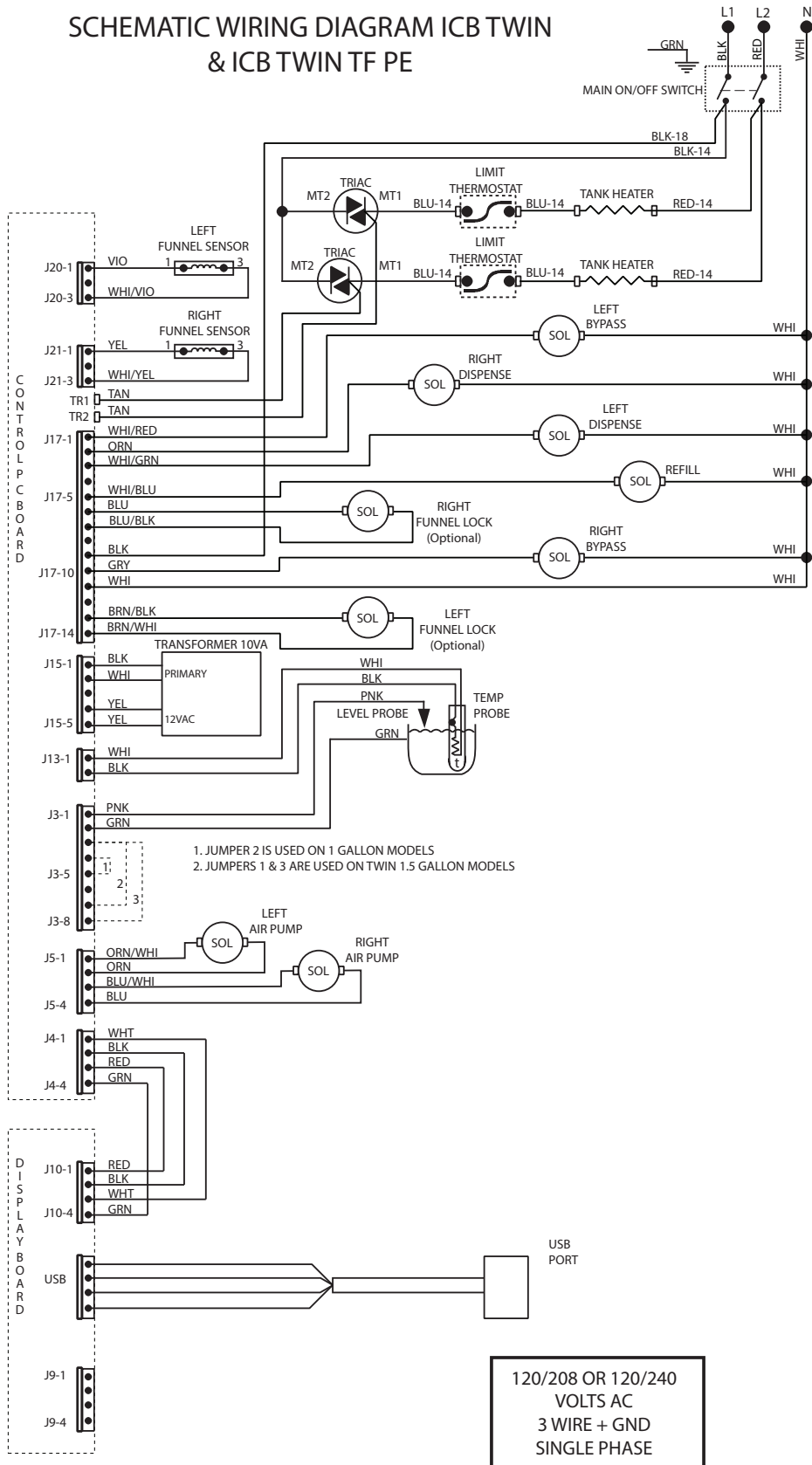

PLATINUM EDITION (120V/208-240V)

SCHEMATIC WIRING DIAGRAM ICB TWIN SH PE

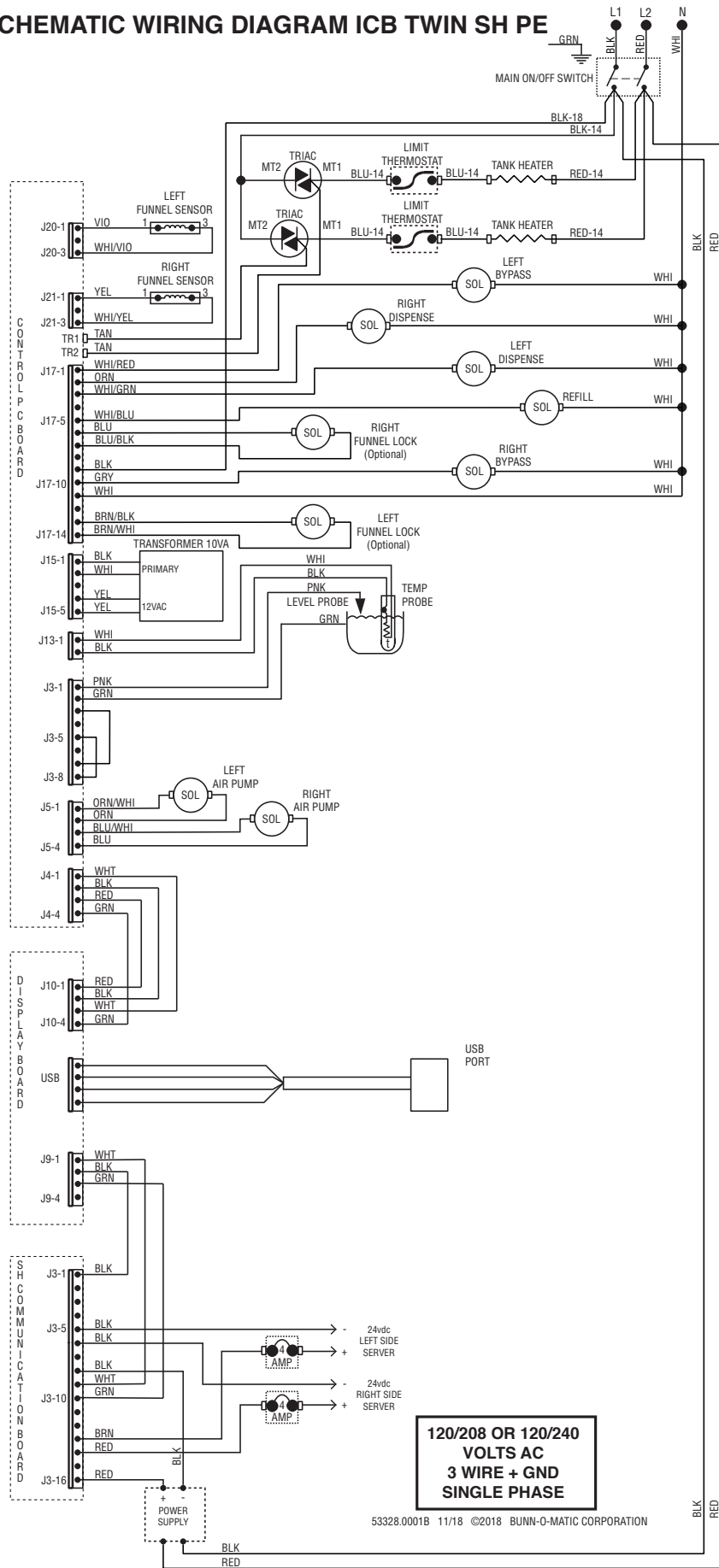

PLATINUM EDITION (200VAC)

SCHEMATIC WIRING DIAGRAM ICB TWIN SH PE 200V

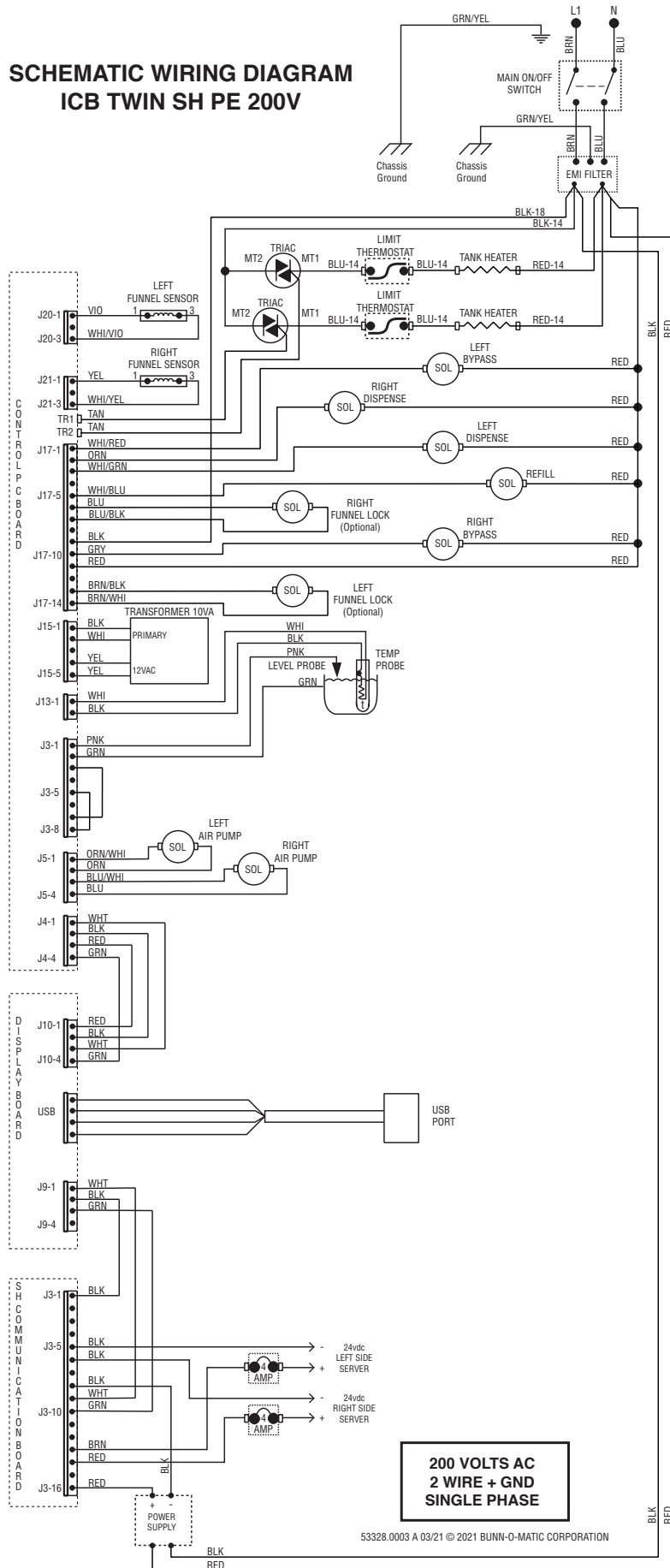

PLATINUM EDITION (200VAC)

SCHEMATIC WIRING DIAGRAM ICB TWIN & ICB TWIN TF PE

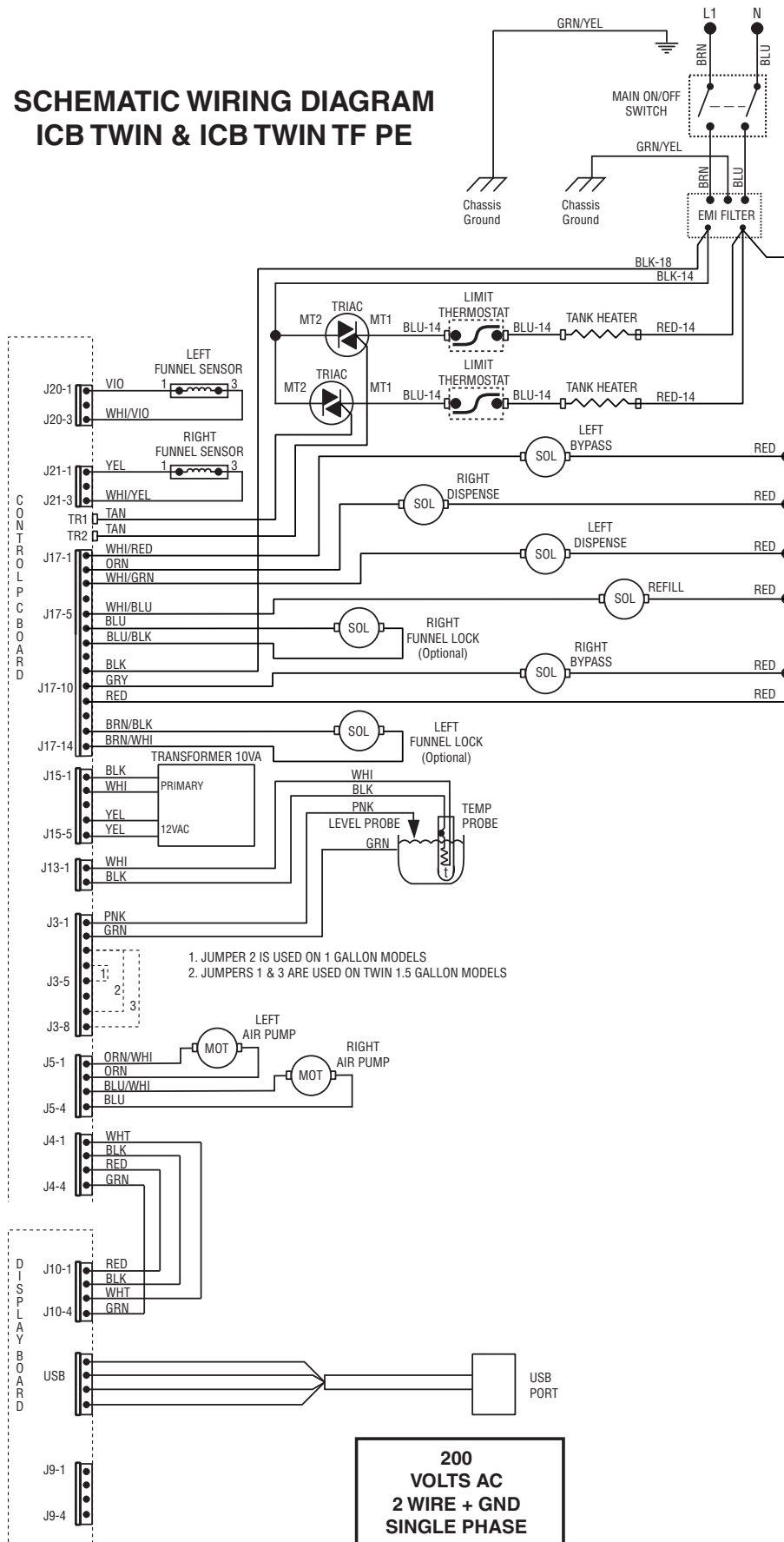

PLATINUM EDITION (120V/208-240V)

SCHEMATIC WIRING DIAGRAM ITCB-DV PE

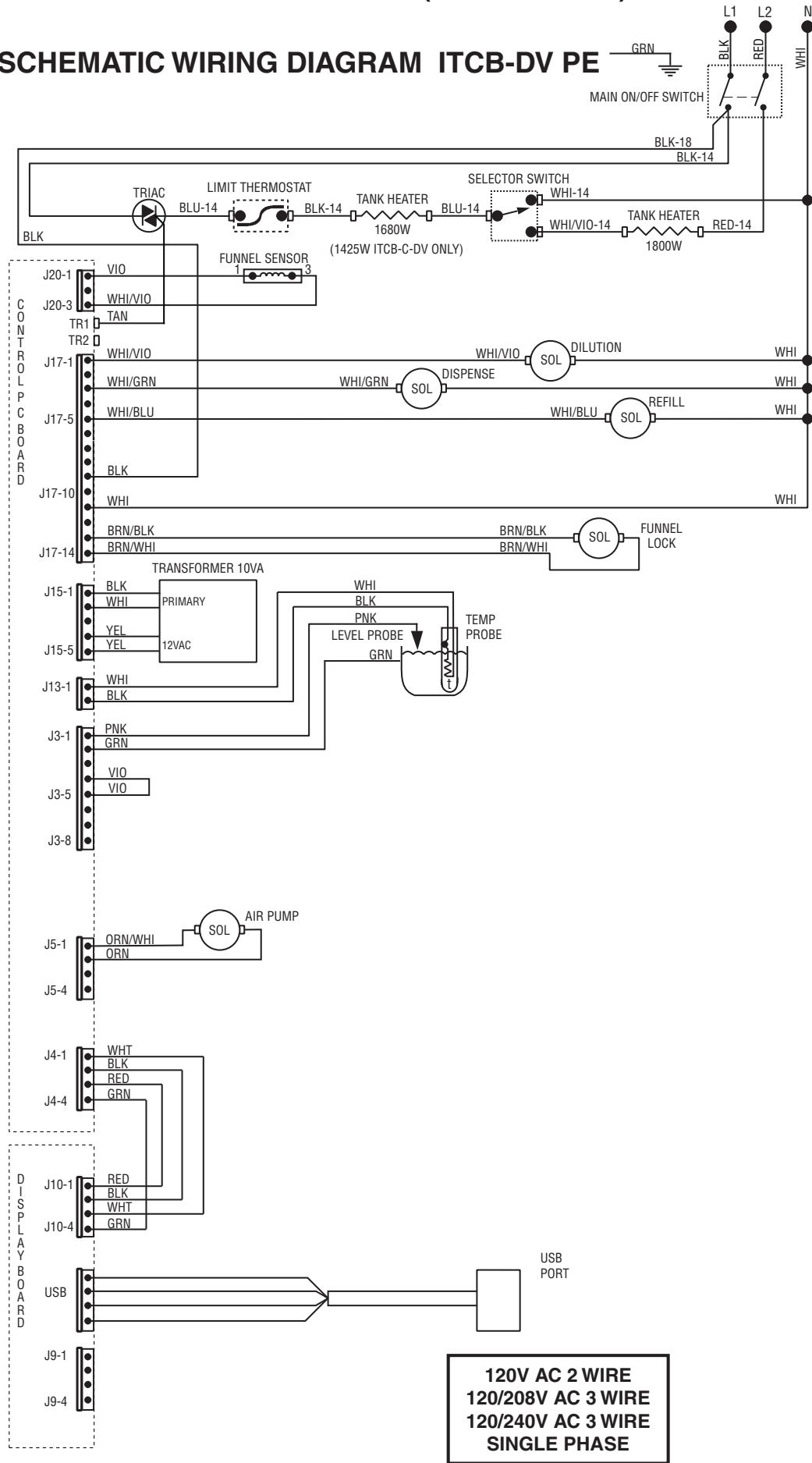

PLATINUM EDITION (120V/208-240V)

SCHEMATIC WIRING DIAGRAM ITCB HV TWIN PE

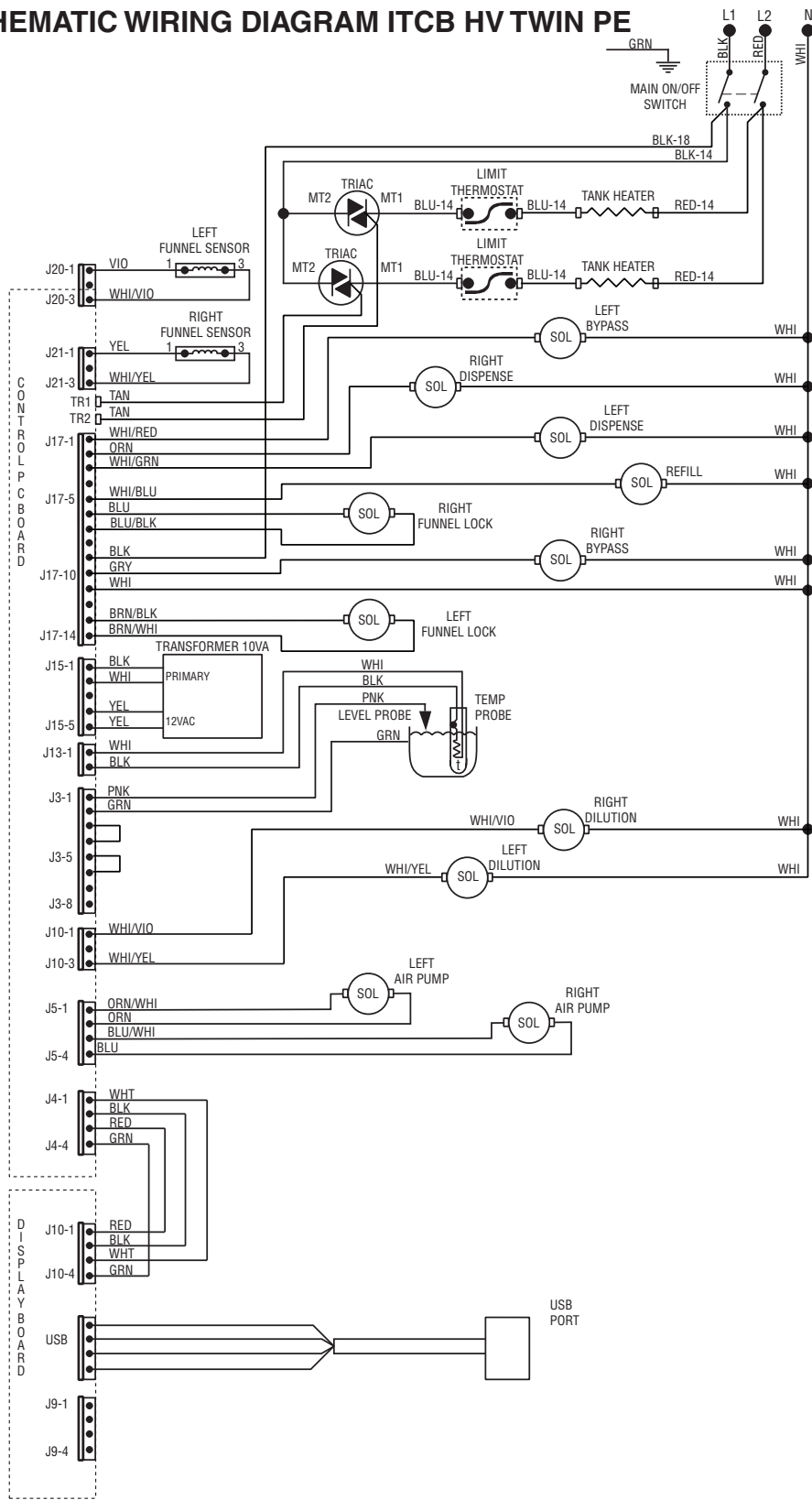

**120/208 OR 120/240
VOLTS AC
3 WIRE + GND
SINGLE PHASE**

37299.0013A 07/18 ©2018 BUNN-O-MATIC CORPORATION