



America

www.BakeMax.com

Project: _____

Item: _____

Qty: _____ Date: _____

BakeMax America BAS Series Oven Range

The BakeMax BAS Range Series are constructed with 430 corrosion resistant stainless steel, including interior burner box which provides extra durability and easy to clean. All supporting brackets inside burner box are made of 304 stainless steel which is resistant to oxidation and corrosion. The cast iron star pattern top burners have no gaskets to leak. Each burner provides up to 30,000 BTU's. Their ovens are fully enameled with porcelain interior and the oven door lifts off easily for cleaning and maintenance. Each unit is NG and is supplied with LP conversion kit.



Model BAS360

Range Features

- Available in 24" (4 Burner), 36" (6 Burner) and 60" Widths (10 Burner)
- Stainless Steel Panel and Sides
- 12" x 12" cast iron top grates designed for easy movement of pots across top sections.
- Deflectors to direct waste to crumb/drip pan.
- Large front panel, promoting safety and functionality.
- Black paint injected aluminum knobs providing for better toughness and durability.
- Easily removable stainless-steel crumb/drip pan.
- 2-Year Limited Warranty

Oven Features

- Oven has Snap Action Thermostat from 210°F to 550°F and 100% Safety Shut Off.
- 26.5" Standard Bakery Depth on all Ovens.
- Double-Sided Enameled Oven Cavity
- Heavy-duty oven wired rack – 1/8" diameter
- The Oven has 3 shelf positions and 1 rack.
- Counterweight Balanced Door
- 2-Year Limited Warranty

Options & Accessories:

- Modular belly rail accessory for 1/6 pans 24", 36"
- Cutting Board 24", 36"
- 6" Swivel Casters with front locking brakes
- Additional Oven Rack
- Gas Quick Disconnect
- Stub Black Flue Riser 4"



Cast Iron Grate



** Due to continuous product improvement, specifications are subject to change without notice.

BakeMax ® / Titan Ventures International Inc.

Warehouses:

20 Caribou St, Moncton, NB E1H 0P3
5705 Valley Belt Rd Independence, OH 44131
1201 E 27th Terrace Pittsburg, KS 66762

Toll Free: 1-800-565-BAKE (2253)
Phone: 506-858-8990
Fax: 506- 859-6929
Email: Sales@BakeMax.com

BakeMax America BAS Series Oven Range

Technical Specifications & Drawings

Model	Width	Depth	Height	Burners	BTU (Range)	BTU (Oven)	Range Orifice #		Oven Orifice #	
							NG	LP	NG	LP
BAS240	24"	35"	62.5"	4	100,000	30,000	40	53	37	52
BAS360	36"	35"	62.5"	6	150,000	35,000	40	53	33	51
BAS600	60"	35"	62.5"	10	250,000	65,000	40	53	33 & 37	51 & 52

Shipping Specifications

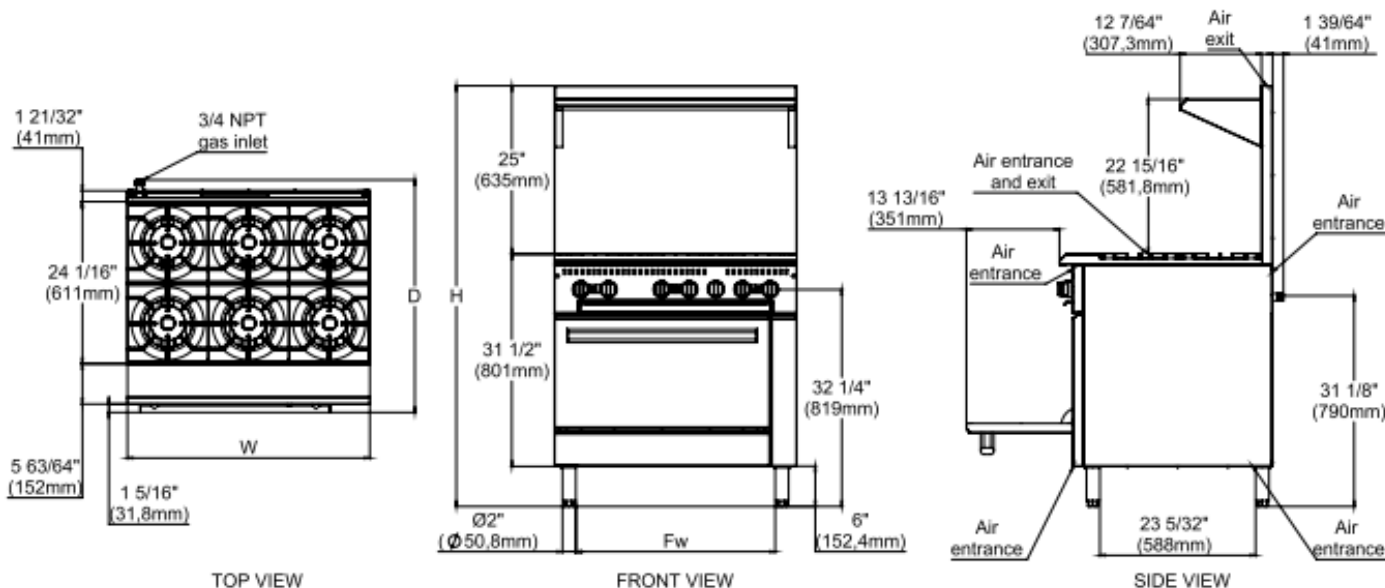

Model	Net Weight lbs. / kg	Crated Weight lbs. / kg	Crated Dimensions (D x W x H)
BAS240	276lbs. / 125kg	397lbs. / 180kg	39" x 29" x 46"
BAS360	386lbs. / 175kg	529lbs. / 240kg	39" x 47.5" x 46"
BAS600	662lbs. / 300kg	1085lbs. / 492kg	39" x 65" x 46"



***Warning:** The minimum supply pressure on this appliance must be set at 4 water column inches for natural gas and 10 water columns for propane gas. Each unit has a 3/4" gas connect at the rear of the appliance.

BakeMax[®] / Titan Ventures International Inc.

Warehouses:

20 Caribou St, Moncton, NB E1H 0P3 
 5705 Valley Belt Rd Independence, OH 44131 
 1201 E 27th Terrace Pittsburg, KS 66762 

Toll Free: 1-800-565-BAKE (2253)
Phone: 506-858-8990
Fax: 506- 859-6929
Email: Sales@BakeMax.com