

BakeMax[®]

Installation and Operation Manual

STANDARD OVEN RANGE LINE



WARNING

Improper installation, adjustment, alteration, service, or maintenance can cause property damage, injury, or death. Read the installation, operating, and maintenance instructions thoroughly before installing or servicing this equipment.



FOR YOUR SAFETY

DO NOT STORE OR USE GASOLINE OR OTHER FLAMMABLE VAPORS OR LIQUIDS IN THE VICINITY OF THIS OR ANY OTHER APPLIANCE.

PLEASE RETAIN THIS MANUAL FOR FUTURE REFERENCE

SAFETY PRECAUTIONS

Important safety instructions

HIS MANUAL CONTAINS IMPORTANT SAFETY INFORMATION. READ CAREFULLY AND SAVE FOR FUTURE CONSULTATION.

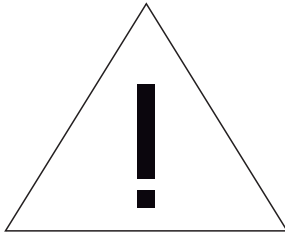

Our service contacts are on the back cover of this manual, so always keep it handy for any need.

This is the safety alert symbol. All safety messages will come after this symbol and the message "WARNING", "IMPORTANT" and / or "DANGER". These words mean:

WARNING

All safety messages mention the potential risk, such as reducing the chance of injury, what can happen if instructions are not followed, and how to prevent accidents.

IMPORTANT

This is essential information that the customer must follow with regard to the equipment.

DANGER

There is a risk of you losing your life or serious injury if instructions are not followed immediately.

Safety warnings

DANGER

Do not store alcohol, gasoline, or any other flammable liquid or vapor near your equipment, as this may have serious consequences and risk of explosion.

During use, the appliance becomes hot. Therefore, care must be taken to avoid contact with the heating elements.

WARNING

This device is not intended for use by persons (including children) with reduced physical, sensory or mental capacities, or people with lack of experience and knowledge, unless they have received instructions regarding the use of the device or are under the supervision of a person responsible for their safety.

Periodically check if the hose and gas regulator are within their expiration date.

If you constantly smell gas, turn off the equipment quickly and check if your equipment gas connections are leaking. If the problem persists, contact your nearest authorized dealer.

- Please observe all local and national codes and ordinances.
- Installation must conform with local codes, or in the absence of local codes, the National Fuel Gas Code, ANSI Z223.1 (latest edition). In Canada, installation should conform to installation codes for gas burning appliances and equipment standard CAN/CGA-B149.1 or the propane installation code, CAN/CGA-B149.2, as applicable.
- Installation must be performed according to the manufacturer's instructions and by qualified and authorized persons.
- For repairs, contact an authorized service technician only and request original replacement parts.
- Before operating the equipment and whenever there is any doubt about its operation, the user has the duty to read and understand this manual in detail.
- Install the equipment in a place where there is sufficient physical space for perfect handling of the equipment.
- Never use your equipment without first installing it correctly.
- If any abnormalities in operation are observed when using the equipment, discontinue use, close the manual gas shut off valve, and call an authorized service technician to correct the problem.
- Any unauthorized alteration and / or tampering is DANGEROUS and will void all warranties.
- Close the gas valve that powers the equipment and check if the knobs are in the closed position when: not in use, before servicing and cleaning the equipment.
- Replace all components before turning on the equipment.
- Use three or more people, or a load lifting device to move and install it.
- Do not soil, remove or obstruct the identification labels.
- For proper operation of the appliance, do not obstruct the flow of gas and ventilation.
- When your equipment is in use, accessible parts can become hot, and children should be kept away.
- Ensure that children do not play with the equipment.
- Always check if the gas connections are correctly installed, have no malfunctions and no gas leaks.

Important tips

- Carrefully keep this manual for future reference.
- Failure to follow the instructions in the consumer manual for equipment installation conditions will void your warranty.
- Never use the equipment if it is damaged or not working properly.
- Water or oil may make the floor slippery and dangerous. To avoid accidents, the floor must be dry and clean.
- Do not repair or replace any part of the equipment unless specifically recommended in the manual.
- Clean the equipment daily after use using neutral detergent. Use abrasive materials only for work surface cleaning.
- Do not use the equipment to heat the environment.
- Do not use loose hanging garments, towels, or large cloths when using near the equipment as they may ignite.
- Prevent water, dirt or dust from coming into contact with the equipment's mechanical and gas components.
- Use only kitchen utensils suitable for the equipment.
- Always use certified hoses and pressure regulators.
- The manufacturer reserves the right to modify, at any time and without prior notice, the contents of this manual.



IMPORTANT

Intended for industrial / professional use.

SUMMARY

01. INTRODUCTION	06
02. EQUIPMENT INSTALLATION	06
2.1 Equipment installation instructions	06
2.2 Recommendations before installation	07
2.3 Gas installation	07
2.4 Installation - Standards and gas codes	08
2.5 Gas pressure regulator	08
2.6 Gas conversion instruction	09
2.7 Gas Leak check	10
2.8 Flue riser assembly	11
2.9. Positioning	11
2.10 Foot leveling	12
2.11 First-time use	12
2.12 Turning on the equipment - Product ignition	12
2.13 Turning on the oven	13
03. KNOWING THE EQUIPMENT	14
3.1 Main features	14
04. CLEANING AND MAINTENANCE	15
4.1 Cleaning	15
4.1.1 Cleaning the outside of the equipment	15
4.1.2 Cleaning the inside of the equipment	15
4.2 Maintenance	16
4.2.1 Preventive maintenance	16
05. TECHNICAL SPECIFICATIONS	17
5.1 Equipment dimensions and weight	17
5.2 Technical data	17
06. LIMITED ORIGINAL COMMERCIAL EQUIPMENT WARRANTY	18

01. INTRODUCTION

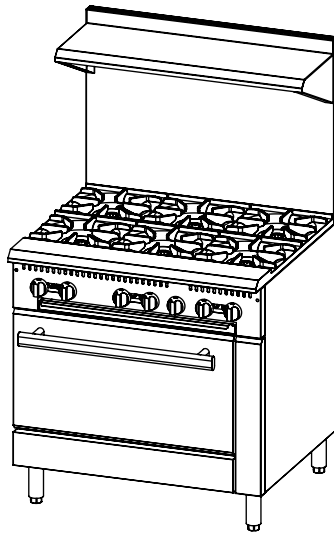

It is another revolution that we offer you, being this a equipment that unites economy, technology and innovative design, thus becoming indispensable for your establishment.

Please read this manual carefully to know your equipment and ensure its correct operation and maximum performance, thus increasing its useful life. It is and will be very helpful in answering questions. Please see.

02. EQUIPMENT INSTALLATION

2.1 Equipment installation instructions

Upon receipt of the equipment, make sure that the equipment is not defective. For assembly, verify first if the accessory kit has the following items: a gas pressure regulator, an instruction manual, the gas conversion injectores and adjustable legs.

Place the equipment the workplace carefully and adjust the foot level.

The gas pressure regulator supplied with the equipment must be installed when the appliance is connected to the gas supply. Installation must comply with local codes or, in the absence of local codes, with the national combustible gas code.

Gas equipment supply piping must be at least 3/4" in diameter.

Adequate space must be left in front of the device for proper maintenance and operation. Provisions should be incorporated into the kitchen design to ensure an adequate supply of fresh air and adequate clearance for combustion chamber overhead operations, for proper combustion and ventilation.

IMPORTANT

Conversion, gas line connection, thermostat calibration, burners, manometer gas pressure adjustment, etc. are all part of the normal installation and will no be paid under warranty. If a warranty technician is called and the unit is installed incorrectly, the end user may be charged.

Proper installation of this gas appliance is the sole responsibility of the end user. It is the buyer's responsibility to determine if the installer is qualified in the installation procedures.

FOR MAINTENANCE, SERVICE, REPAIRS OR INSTALLATIONS - contact the factory to schedule authorized service.

CLEARANCES

The appliance area must be kept free and clear of all combustibles.

Model	Combustible		Non-combustible	
	Rear	Sides	Rear	Sides
Standard Oven Range Line	8"	6"	0"	0"

RATING PLATE

Information on this plate includes the model, serial number, BTU/h input of the burners, operating gas pressure in inches WC, and whether the appliance is orificed for natural or propane gas. When communicating with factory about a unit or requesting special parts or information, rating plate data is essential for proper identification.

2.2 Recommendations before installation

Before installing the gas supply system, observe the pipes and fittings, check the components for dirt, clean internally with compressed air to eliminate possible particles, and prevent burners and valves from becoming clogged.

After cleaning, use thread sealant to connect the equipment to the gas network. For correct application, avoid concentrating the compound on the first two threads of the pipe, otherwise it may generate particles that will clog the system injectors.

2.3 Gas installation

Your gas appliance will give you peak performance when the gas supply line is of sufficient size to provide the correct gas pressure. The gas line must be installed to meet the local building codes or National Fuel Gas Code ANSI Z223.1 Latest Edition. In Canada, install the appliance in accordance with CAN/CGA-B149.1 or .2 and local codes. Gas line sizing requirements can be determined by your local gas company or, in North America, by referring to the National Fuel Gas Code, Appendix C, Table C-4 (for natural gas) and Table C-16 (for propane). The gas line needs to be large enough to supply the necessary amount of fuel to all appliances without losing pressure to any appliance.



WARNING

Never supply the appliance with a gas other than the one that is indicated on the data plate. Using the incorrect gas type will cause improper operation and could result in serious injury or death. If you need to convert the appliance to another type of fuel, contact the dealer your purchased it from.

Never use an adaptor to make a smaller gas supply line fit the cooker connection. This may not allow the correct amount of gas flow for optimum burner operation, resulting in poor cooker performance.

2.4 Installation - gas standards and codes

 **IMPORTANT**

FAILURE TO INSTALL THE PRESSURE REGULATOR WILL VOID YOUR WARRANTY.

In North America, gas appliances equipped with casters must be installed with connectors that comply with the Standard for Connectors for Movable Gas Appliances, ANSI Z21.69.CSA 6.16 Latest Edition. This connection should include a quick disconnect device that complies with the Standard for Quick Disconnect Devices for Use With Gas Fuel Appliances ANSI Z21.41.CSA 6.9 Latest Edition.

Installation of this appliance must be in accordance with local installation codes, including:

1. The appliance and its individual shut off valve must be disconnected from the gas supply piping system during any system pressure testing when this teste pressure exceeds 1/2 PSI (3.45 kPa).

2. The appliance shall be isolated from the gas supply piping system by closing the manual shut off valve during any pressure test of the gas supply piping system at test pressures equal to or less than 1/2 PSI (3.45 kPa).

GAS CONNECTION

The external thread of equipment's intake-tube is 3/4" NPT. For proper operatorion, the gas supply line must be the same size or larger. Gas line size should not be reduced at any point along the supply line.

MANUAL SHUT OFF VALVE

A gas pressure regulator and a shut off valve supplied by the technical shall be installed in the gas service line before the appliance - in a physical location where it can be reached quickly in an emergency.

2.5 Gas pressure regulator

The gas pressure regulator (which accompanies the equipment) is of utmost importance for its operation and is indispensable. The pressure regulator must be installed in the equipment supply gas line (failure to install the pressure regulator will void the equipment warranty).

Regulators are supplied with 3/4" NPT connection ranges.

The regulator is factory set by 102 mmH₂O ((4" WC) water column) gas pressure at connector (natural gas) and gas pressure at 254 mmH₂O (10" WC) connector for LPG gas operation.

Before connecting the regulator, check the supply line pressure in the equipment. This may not exceed the maximum pressure of 3.45 kPa (1/2 PSI). If the gas supply line pressure is higher than indicated, use a pressure reducing regulator.

At the bottom of the regulator body there is a gas direction arrow to minimize installation error. This arrow should point to the device's direction of entry into the equipment.

The blue air vent cap on the top of the regulator is part of the regulator and should not be removed.

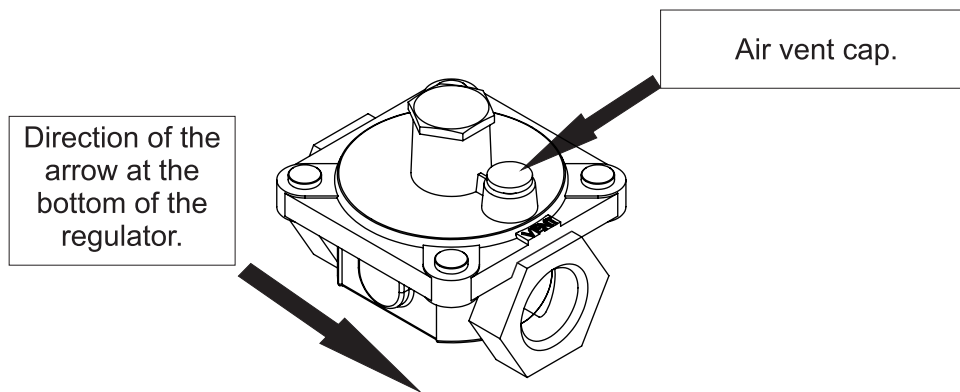

! IMPORTANT

Visually check all inlet pipes supplied by the installer and/or blow them out using compressed air to clean out any dirt or debris (threads or other foreign matter) before installing a service line. These particles will clog the gas holes when gas pressure is applied. Compounds used in appliance pipe threaded joints shall be resistant to the action of GN and LPG gas and shall provide a gas tight seal to prevent leakage.

When installing the pressure regulator remember that it can support 1/2 PSI (3.45 kPa).

When installing LPG, you have high source pressures ranging from 20 PSI (127.89 kPa) to 100 PSI (689.48 kPa). If the LPG tank's high pressure gas line is directly connected to a unit without the proper reduction regulator, it will rupture the diaphragm in the valve, making it useless.

Any adjustment to the regulator should be done only by qualified and licensed personnel with the appropriate calibrated test equipment.

Connections must be made by a licensed and qualified contractor.

2.6 Gas conversion instruction

The **Standard Industrial Range with Oven** is produced to use LPG or NG gas. Then check to see if the gas used in your region is compatible with the type of gas for which the equipment was manufactured. If not, gas must be converted to Natural Gas (LN) or Liquefied Petroleum Gas (LPG). To do this, you must purchase from the company, separately from the equipment, the gas conversion kit containing the range and oven injectors and the range spreader.

! IMPORTANT

To perform gas conversion, a licensed and qualified technician is required.

For conversion the following guidelines should be followed:

1. Close the manual gas valve and disconnect the product from main pipeline gas, making sure that there is no leakage. Then remove the pressure regulator from the gas inlet on the equipment to make work easier.
2. Remove the knobs, thermostat (1) and the equipment's waste drawer (2).
3. To remove the panel (4) from the equipment, it is necessary to remove the two screws (3) from the front of the panel with the aid of a screwdriver, after simply detaching the panel from the equipment.
4. Remove grills (10), flame spreaders (9) and burners (8).
5. Remove the screws that secure the distribution tube inside the equipment with a double screwdriver.

6. Remove the dispensing tube (5) and then pull the dispensing tube all the way in. out (horizontally) and place it on a flat surface. It is ideal that this step is carried out by two or more people.

7. In place of the removed gas injectors (6), place the new injectors that are in the accessory kit. But first apply some pipe sealant to the valve thread and the screw in the new injectors to the correct gas type.

8. To change the oven injector, open the movable bottom panel and remove the screws (11) from the injector holder (12).

9. Remove the injectors (13) with a 1/2" wrench.

10. Repeat the same procedure as 7, but now for the range.

11. After changing the gas injectors (6 and 13), reassemble your equipment. Replace the distributor pipe, however, now with the new injectors. After fitting the panel and securing it with the screws that were removed previously, as well as the knobs and the waste drawer.

12. Connect the burners and replace the flame spreader. Finally, position the grills in their places.

13. Convert the pressure regulator by inverting the docking device under the regulator cover. This will require a reasonable amount of force. Do not remove the spring. When replacing the cover, make sure the insert of the socket is facing upwards in the middle of the spring. As shown in the image on the side.

14. Refit the pressure regulator to the gas inlet of the equipment.

15. Apply the "Warning" sticker for the gas to be used on the front of the unit for future reference.

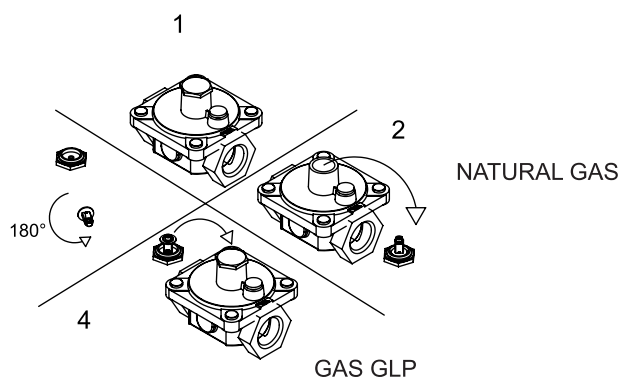
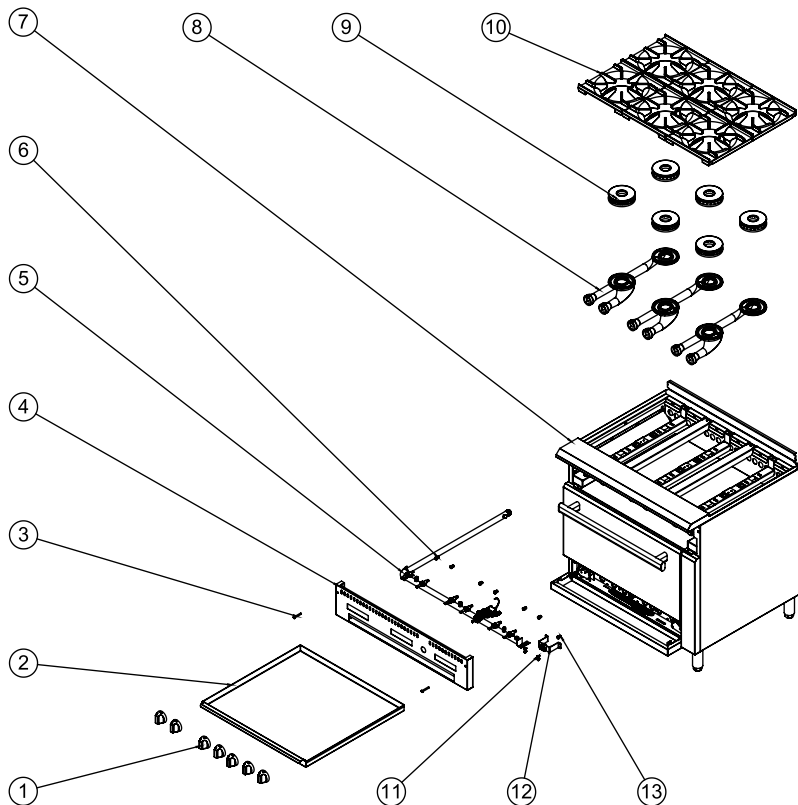

2.7 Gas leak check

Before lighting the equipment and putting it into operation, check all gaskets on the gas supply line for leaks. For this, do not use any type of wrench to check for leaks, use a sudsy soap and water solution.

Follow the steps below for the correct procedure to power on:

1. Turn pilot valves to OFF position by turning adjusting screws clockwise.
2. Turn on the manual gas valve on the inlet side of the gas supply line.

3. Check for gas leaks at the flexible coupling or gas connector connection using a soap solution.
4. In moderation, spray or scrub the solution with soap on gas connections - active bubbling indicates the location of the gas leak.
5. If a gas leak is detected, turn off the manual gas valve at the inlet side of the gas line. Call your certified and licensed service technician.
6. If the equipment has no gas leak, continue with the equipment operating instruction.

2.8 Flue riser assembly

To assemble the flue riser and shelf on the range it is necessary to follow the following steps:

1° Fit the flue riser on the back (1) to the range (2).

2° Use four screws with four flat washers to fix the internal part of the flue riser on the side of the equipment (two screws and two washers on each side), as shown in image 1.

For 60" models, you must also perform the fixation in the central part of the flue riser with 2 screws (6), according to the image 2.

3° Finally, fit the shelf (5) to the flue riser.

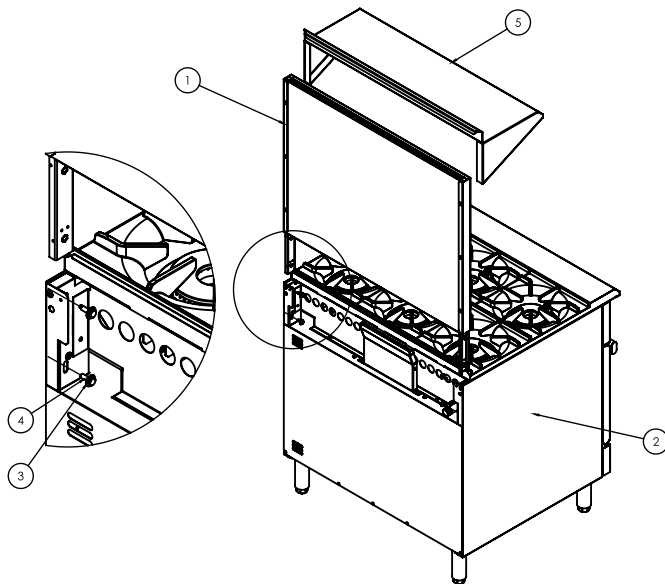

Image 1

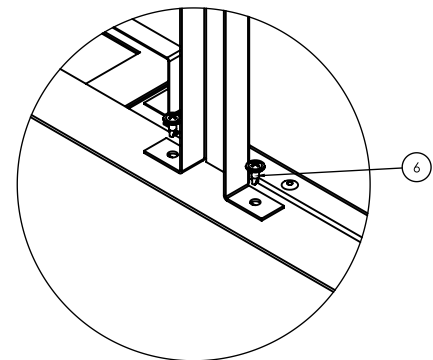
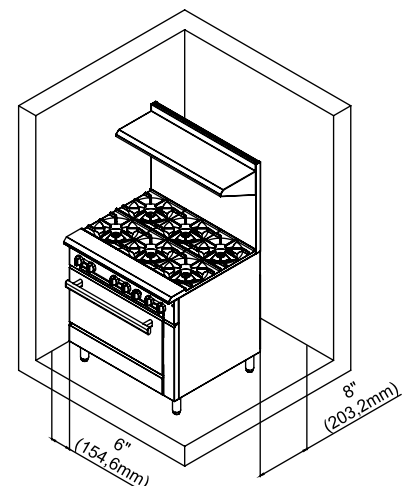

Image 2

2.9 Positioning

- Installation must be on a flat and level surface.
- It is recommended to install the equipment under hoods or exhausts.
- There must be a distance of at least 8" (203.2 mm) at the rear, 6" (152.6 mm) at the right and left of the equipment from combustible surfaces. As shown in the figure below.



2.10 Foot leveling

For a good operation of the **Standard Oven Range Line** it is ideal that the equipment is level and fixed perfectly with the work surface. To adjust the leveling, turn item 1 (identified in the drawing) counterclockwise to open and clockwise to close to find the best position to operate the equipment safely.

1 – Foot regulator.

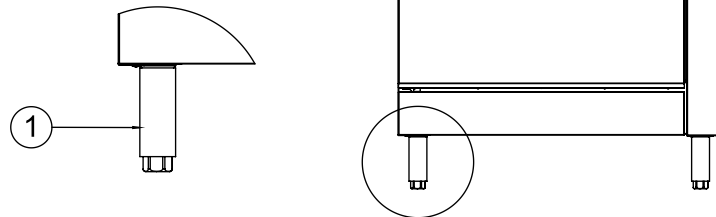

2.11 First-time use

To protect the equipment against possible damage caused by shock or rocking from transportation, burners, grids and grills are secured by plastic straps. The sides, and the waste tray have a protective PVC film. Remove any plastics, straps, or protective film from the equipment before operating the equipment.

Before using the equipment for the first time you should clean it with a sponge, mild soap and water. Only then will the equipment be ready for use.

2.12 Turning on the equipment - product ignition

1. Open the manual gas supply valve (which will release gas into the equipment).
 2. Light the burner pilot until the flame ignites, repeat on all others (see image below).
- Note: The ignition order does not interfere with the use of the equipment.

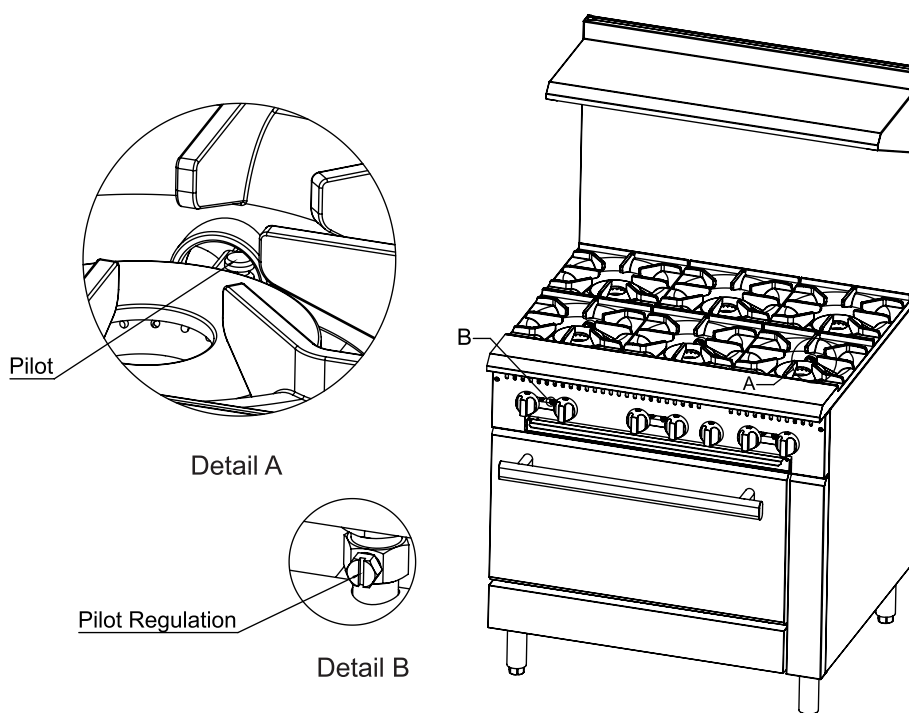

3. Turn the knob which you want counterclockwise (through the knob adjusts the flame).
4. Make sure the burner is lit. If the burner does not light, repeat the procedure.
5. After lighting all burners, you can turn off the main burners and turn them back on simply by turning the corresponding knobs.

Note: The pilot burner flame is factory set according to the gas for which the equipment was originally manufactured. Always check that the pilot burner flame is lit. If it is not, perform the procedures described above again.

NOTE:

If you need to adjust the pilot valves (one pilot valve corresponds to two burners) do the following:

- 1-Turn the pilot adjusting screw counterclockwise, then light the pilot with the aid of the igniter (wick) accompanying the equipment and adjust the flame to a height of approximately 13/64"(0.5 cm);
- 2- Turn on the gas valve by turning the knob counterclockwise to light the main burners;
- 3- To shut down completely, close the gas valves by turning the knob clockwise and turn the pilot adjusting screw clockwise to close the gas for the pilots.

Pilot screw adjustment

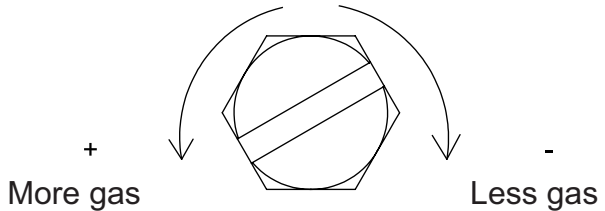

2.13 Turning on the oven

- 1) In order to light the oven burner pilot, open the lower movable panel.
- 2) Turn the thermostat's knob counterclockwise to the pilot position and keep it pressed up the end of its course.
- 3) Light the pilot (image to the side).
- 4) Keep the knob pressed for 15 seconds after the pilot flame is ignited.
- 5) Release the knob and make sure that the pilot flame remains lit. If not, repeat the operation.
- 6) Turn the knob up to the desired temperature counterclockwise.
- 7) To turn the oven off, press and turn the knob clockwise to the "OFF" position.

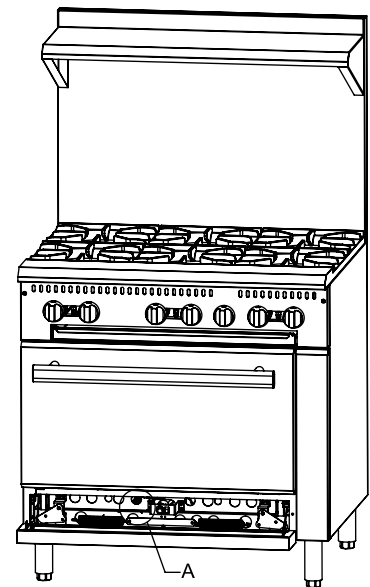
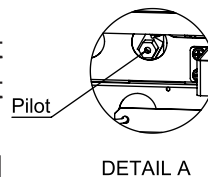

IMPORTANT

When using the equipment for the last time in the day, the gas valve (manual gas supply valve) should be closed.

03. KNOWING THE EQUIPMENT

The **Standard Oven Range Line** was developed in order to provide the best experience during cooking activities, combined with a high standard of quality, high performance and durability, meeting the needs of a professional kitchen.

Made of stainless steel, providing durability and ease when cleaning.

Cast iron grills with 8 points, resistant and flat, bringing greater convenience when it comes to moving with the pots on the stove.

The equipment is supplied with manual lighting of the pilot system. This should be lit only once a day, and so should stay on throughout the workday as consumption is very low.

The **Standard Oven Range Line** can present two models in its Flue Riser, according to the client's request: low Flue Rise (P.B.) or simple (P.S.) Flue Riser. The first only allows air to escape, while the second, in addition to allowing air to escape, has a panel in order to place groceries or kitchen accessories.

3.1 Main features

RANGE

- Available in 24" (610mm), 36" (915mm) and 60" (1,525mm) width.
- Stainless steel panel and sides.
- 12" x 12" cast iron top grates designed for easy movement of pots across top sections.
- Deflectors to direct waste to crumb/drip pan.
- Large front panel, promoting safety and great functionality.
- Black paint injected aluminum knobs providing for better toughness and durability.
- Easily removable stainless steel crumb/drip pan.

OVEN

- Oven with snap action thermostat from 210°F to 550°F and 100% safety shut off.
- Double-sided enamel oven cavity (Exterior and interior top, bottom, and side).
- Heavy-duty oven wired rack – 1/8" diameter.
- The oven has 3 shelf positions and 1 racks.
- Counterweight balanced doors.

04. CLEANING AND MAINTENANCE

4.1 Cleaning

DANGER

Do not use toxic or high chemical cleaning materials. See all instructions given by the cleaning equipment manufacturer.

- After using the **Standard Oven Range Line** and the equipment is not working or hot, clean it to remove food residue. Remove the waste drawer for debris removal and cleaning.
- Use a non-abrasive sponge with mild detergent and water to clean the equipment.
- Never use sharp, pointed materials or abrasive products (with corrosive elements in the formula) on stainless steel components, but on grills it is possible;
- Keep in mind that constant and correct cleaning is critical to the proper functioning of the equipment.
- To perform cleaning, the equipment must be completely disconnected from the gas, thus avoiding any accident;
- NEVER attempt to move or slide the equipment when it is hot. ALWAYS let the unit cool down and empty the waste drawer before attempting to relocate or move the unit.
- ALWAYS, after the end of the working day, clean the grills and burners and turn them on to remove moisture. This practice is recommended between one working day and another, thus avoiding its oxidation;

4.1.1 Cleaning the outside of the equipment

The **Standard Oven Range Line** has external stainless steel coating and for its correct cleaning it is necessary to follow the following guidelines:

- Set aside for to cool. Normal daily dirt can be removed with a mild detergent or soap solution applied with a damp cloth. Wash and dry thoroughly;
- To remove deposited grease, apply a cleanser in the direction of the polished lines on the metal. NEVER rub in a circular motion.

4.1.2 Cleaning the inside of the equipment

- Let the inside of the equipment cool completely. Use a non-alkaline cleaning agent following the manufacturer's recommendations;
- Do not use abrasive products;
- Flammable products and steam cleaning machines cannot be used for oven cleaning either;
- Rinse well with water at room temperature, clean and dry thoroughly.

Oven

- Clean the oven frequently, as constant and correct cleaning is essential for the perfect operation of the equipment.
- If grease spills inside the oven, clean the dirty area after the equipment has cooled using a non-abrasive sponge, water and mild detergent;
- The grids are easy to remove, just fittings. For cleaning it is recommended to use a non-abrasive sponge, water and neutral detergent.

4.2 Maintenance

Maintenance is one of the precautions to be taken for a good equipment life. Proper cleaning, installation, checking and equipment life all contribute to reduced maintenance. Before any maintenance, verify that the gas connections, regulators or check valves must be completely closed and disconnected from the equipment.



IMPORTANT

The maintenance of the equipment should only be performed by a technician authorized by the manufacturer.

The operator should be familiar with how to connect and disconnect the restrictions / removable parts. If the restriction is removed for maintenance or cleaning, it must be reconnected before using the equipment again.

4.2.1 Preventive maintenance

To reduce downtime and maximum efficiency, service your appliance once or twice a year, depending on the amount of use. To do this ask a technician to:

- Examine the air inlets on the burners and the panel, as well as the air outlet at the rear of the appliance, at least twice a year;
- Clean and adjust burners, regulators and etc. twice a year;
- Check and calibrate the equipment gas supply system pressure at least once a year;

05. TECHNICAL SPECIFICATIONS

5.1 Equipment dimensions and weight

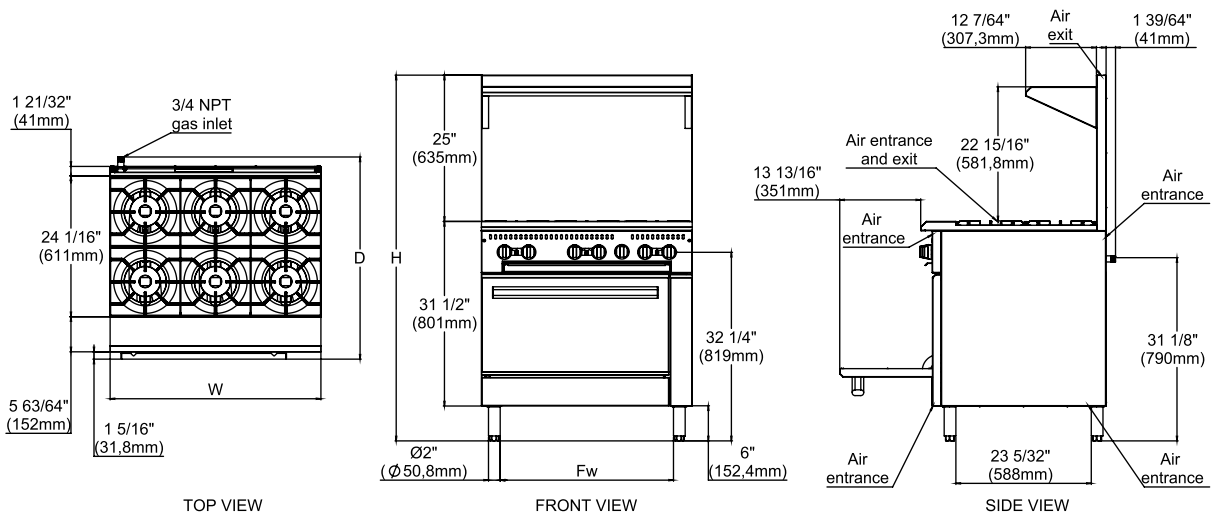

Models	Exterior Product Dimensions & Weight						Shipping Crate Dimensions & Weight				Oven - Inside			
	Width (W)	Depth (D)	Height (H)		Fw		Weight	Width	Depth	Height	Weight	Width	Depth	Height
			P.B	P.S	Fw1	Fw2								
BAS240	24" (610mm)	35" (889mm)	41 17/64" (1048mm)	62 33/64" (1588mm)	17 19/32" (447mm)	276 lb (125 kg)	28 5/32" (715mm)	39 1/64" (991mm)	45 43/64" (1160mm)	1085 lb (492 kg)	18 57/64" (480mm)	26 1/2" (673mm)	15 23/64" (390mm)	
BAS360	36" (915mm)				29 39/64" (752mm)	386 lb (175 kg)	47 7/16" (1205mm)				529 lb (240 kg)			26 31/32" (685mm)
BAS600	60" (1525mm)				17 19/32" (447mm)	29 39/64" (752mm)	662 lb (300 kg)				64 61/64" (1650mm)			18 57/64" - 26 31/32" (480mm - 685mm)

5.2 Technical data

PRODUCT	MODEL	GAS SUPPLY						MANIFOLD PRESSURE	
		MODEL	BURNERS	GAS TYPE	NOZZLE	PER BTU	PER Kcal	TUBE PRESSURE (in. W.C)	
						BTU	kcal/h		
Standard Oven Range Line	BAS240	RANGE	4	NATURAL GAS	#40	100,000	25,200	4	
				L.P. GAS	#53			10	
		OVEN	1	NATURAL GAS	#37	30,000	7,560	4	
				L.P. GAS	#52	27,000	6,805	10	
	BAS360	RANGE	6	NATURAL GAS	#40	150,000	37,800	4	
				L.P. GAS	#53			10	
		OVEN	1	NATURAL GAS	#33	35,000	8,820	4	
				L.P. GAS	#51	33,000	8,315	10	
	BAS600	RANGE	10	NATURAL GAS	#40	250,000	63,000	4	
				L.P. GAS	#53			10	
		OVEN	2	NATURAL GAS	#37	30,000	7,560	4	
				#33	35,000	8,820			
L.P. GAS	#52	27,000	6,805	10					
#51	33,000	8,315							

06. LIMITED ORIGINAL COMMERCIAL EQUIPMENT WARRANTY

BAKEMAX offers a warranty to manufactured equipment as is specified below: Every alleged manufacturing defect must be analyzed only by technical assistance from BAKEMAX.

When proven, an eventual manufacturing defect repair will be free of charge. Equipment repaired without proper authorization from the manufacturer or altered, disassembled, and/or utilized ajar from the indications presented in their respective guides, are not covered by this warranty.

The warranty refers only to the normal use of the equipment, considering the following of the recommendations and instructions contained in the guide that comes with the product. For all purposes, the brand gives a legal guarantee of two (2) years from the date of issuance of the purchase invoice, being mandatory it is a presentation to the customer service presented under this warranty term.

It is important to consider that glass, light bulbs, resistors, contactors, fuses, relays, solenoids, digital controllers and thermostats, are not covered by this warranty. In the case of its electric motors, being manufactured by a third party, when defective should be sent to its authorized service. This guarantee refers only to the parts and components manufactured by BAKEMAX, covering also labor costs in such repairs. It is the clients' responsibility to communicate any findings of manufacturing defects to BAKEMAX through the local distributor.

In case of bulky equipment (roasters, ovens, heating stoves, industrial ovens, etc.), technical assistance, when necessary, carry out the visit directly to the customers' location/establishment. On the other hand, small-sized equipment (heaters, plates, saucers, pots, sandwiches, drinking fountains, coolers, etc.), the customer must, on their own, direct them to any of the brand's authorized service.

Defects in electrical, improper installation, shipping damage done by third parties, or weather invalidate the warranty.

IMPORTANT: only assemble of the product with safety equipment (goggles, leather gloves, etc.) and suitable tools to the specific product. BAKEMAX will not be held responsible for any injury derived from the lack of attention and care, as well as improper use of the equipment, even when in operation.

CONSUMER AND PRODUCT IDENTIFICATION

Purchase Date:	
Model Number:	
Serial Number:	
Installed Date:	
Install By:	
Gas Type:	

Keep this manual, as it contains important information for questions, and adjustments. The same will be required for the warranty claim if required.

BakeMax[®]

Titan Ventures International Inc.
270 Baig Blvd, Suite A3
Moncton, NB E1E 1C8
Phone: (506) 858-8990
Email: sales@bakemax.com
Web site: www.bakemax.com