

ASSEMBLY INSTRUCTIONS

SDL | STAGE DOLLY

TOOLS NEEDED:



Adjustable Wrench

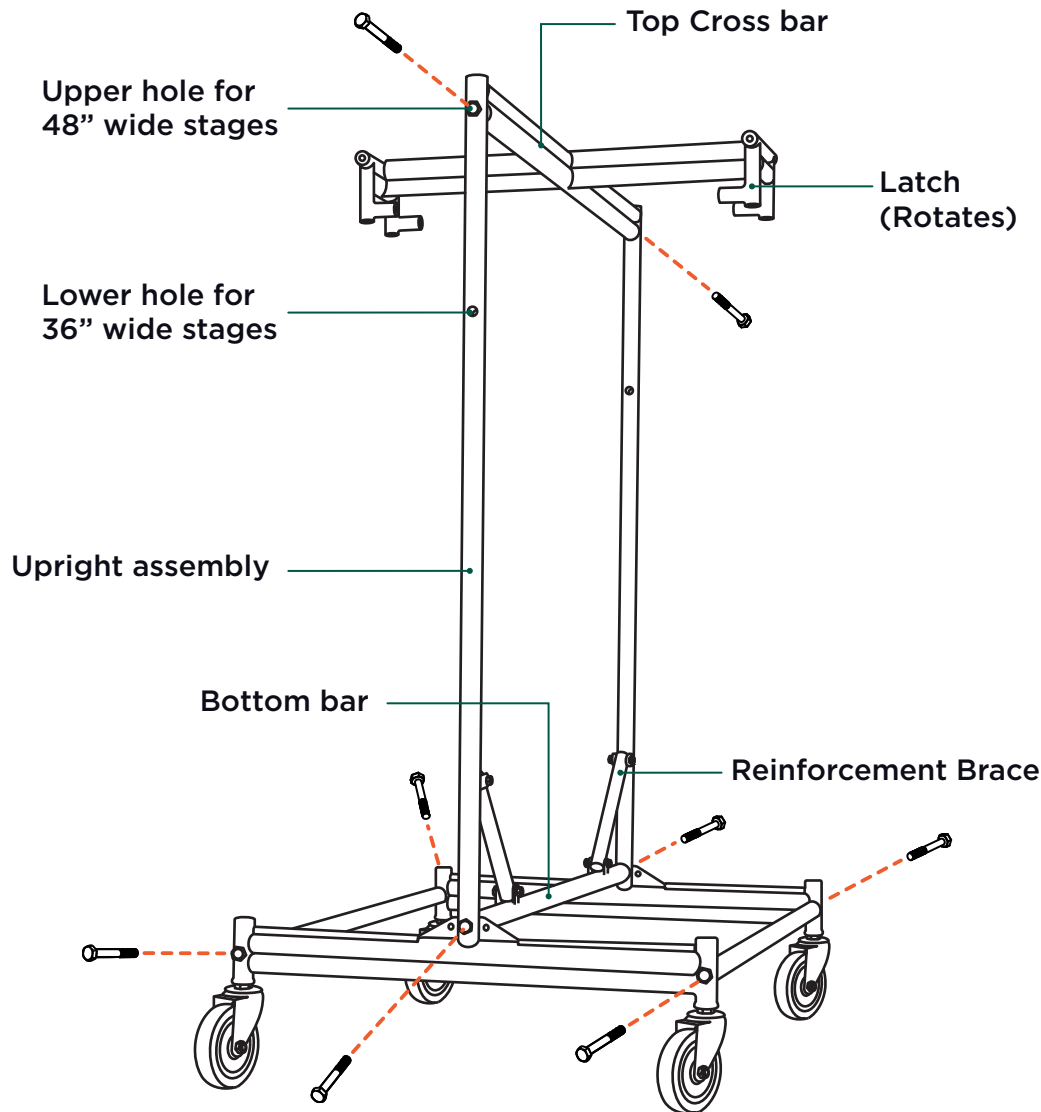

 **Double check all screws to be tightened securely before use. Check all screws periodically. Failure to completely tighten the screws may result in tipping & possible injury!**

LOADING STAGES:

- 1** For 48" wide stages, screw the top cross bar in the upper holes. For 36" wide stages screw the top cross bar into the lower holes.
- 2** Once dolly is assembled, rotate latch and load stages. Release latch into original position to prevent stages from falling off the dolly.

Dear Customer, Thank you for your purchase. Although extreme care goes into manufacturing & packaging of this product, mistakes are possible. If you encounter any missing parts or difficulty in assembly, please contact our customer service Toll Free at 1-800-261-4112 or info@nationalpublicseating.com for courteous & immediate resolution to your problem.