

# MOTAK

## Bakery Display Case w/ Straight Glass

Model #: MCD47-2-X

### Product Details

- Refrigeration system keeps meats and deli products at safe temperatures between 36°F and 43°F
- Sliding glass doors on staff side
- Adjustable glass shelves provide extra-large viewing area to maximize bakery product presentation
- Made with shatter-resistant tempered glass
- Electronic control system makes it easy to adjust temperature set point and defrost frequency
- Efficient LED interior lighting
- Pre-installed 2" swivel casters
- Eco-friendly R290 refrigerant
- Condenser coil is easy to access for cleaning and service

Not suitable for installation in non-commercial or residential applications.



### Warranty

1 year parts & labor and additional 2 years on compressor

### Certifications



### Specifications

Model	Doors	Shelves	Cabinet Dims (in)			HP	Voltage	Amp	NEMA Plug	Cord Length (ft)	Crated Weight (lbs)
			Width	Depth	Height						
MCD47-2-X	2	2	47.25"	28.75"	47.25"	1/4	115/60/1	5.58	5-15P	10 ft.	418 lbs.

### Plan View

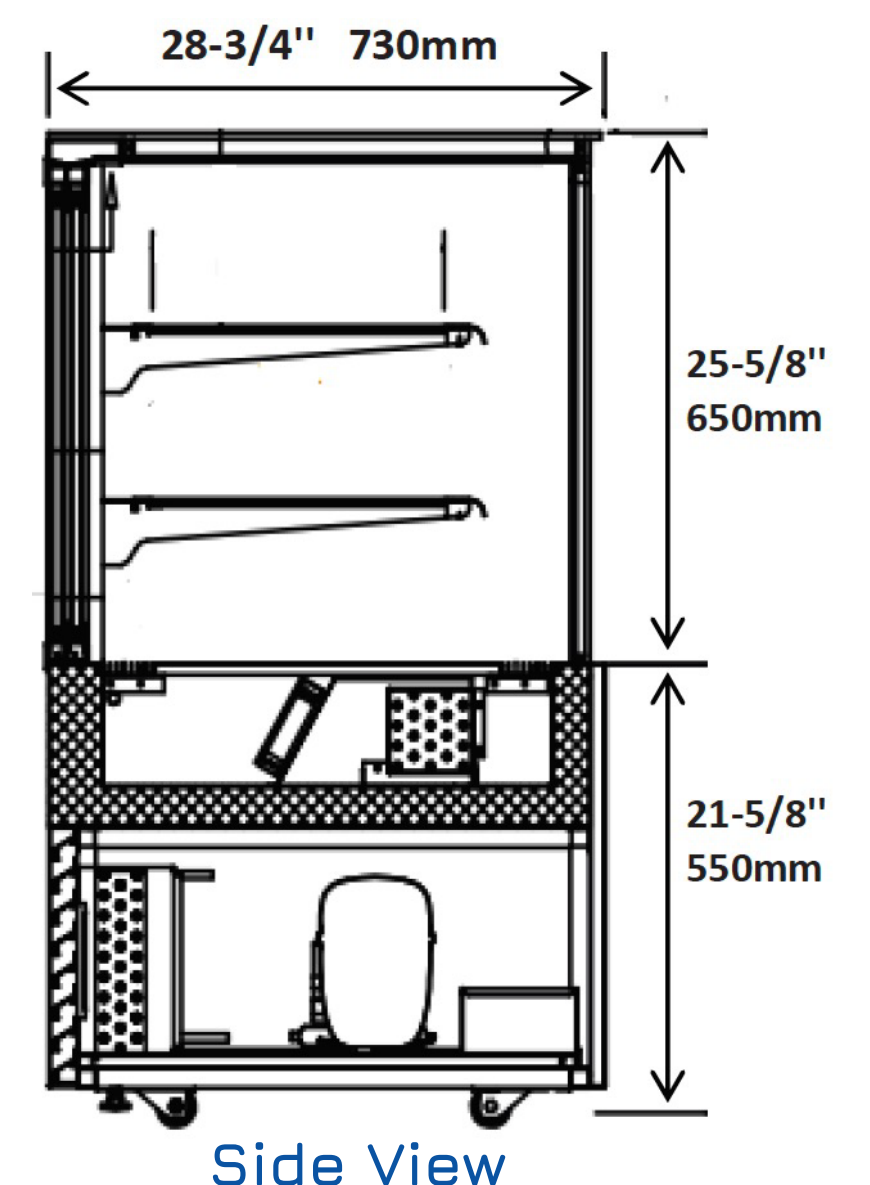
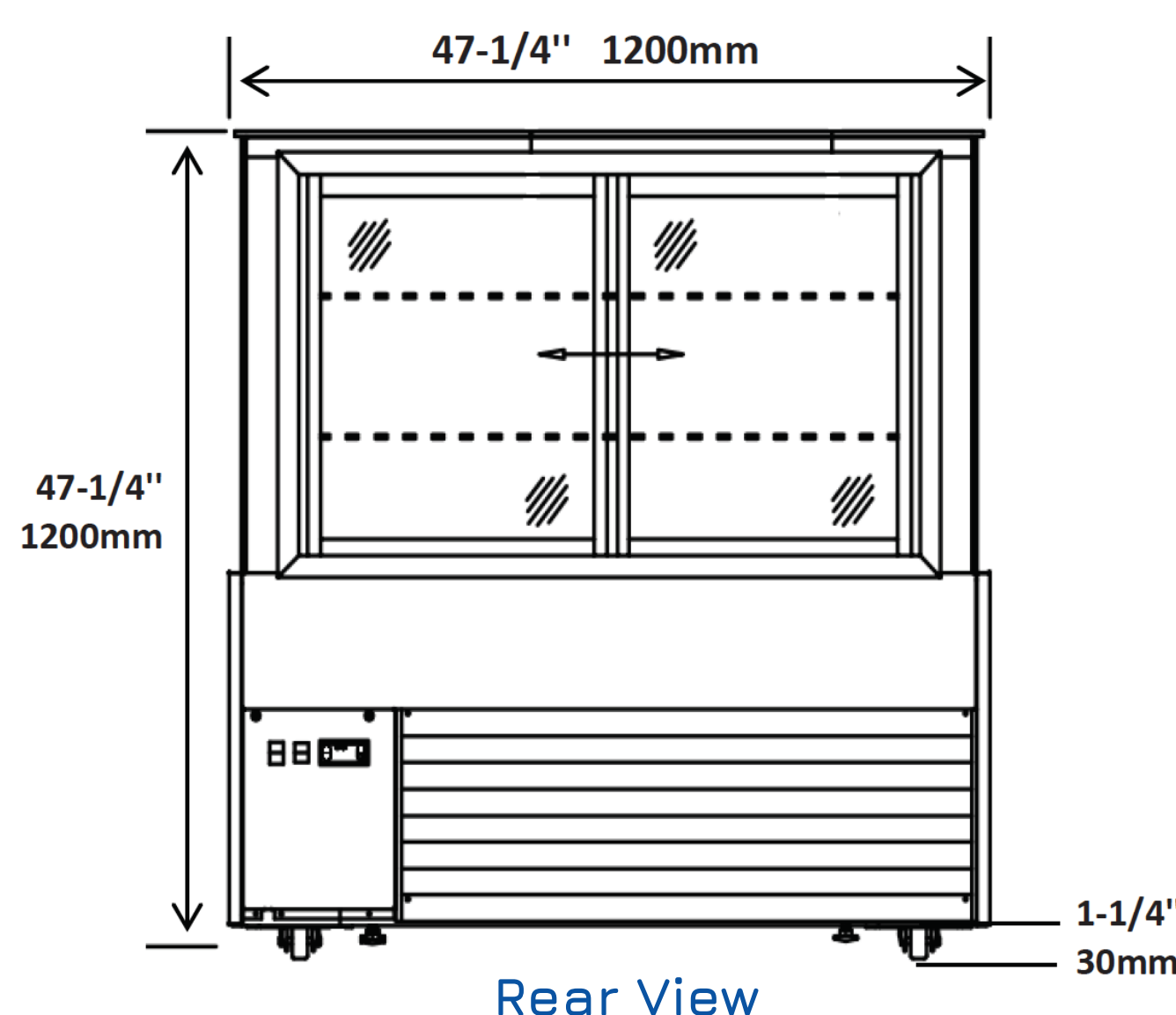
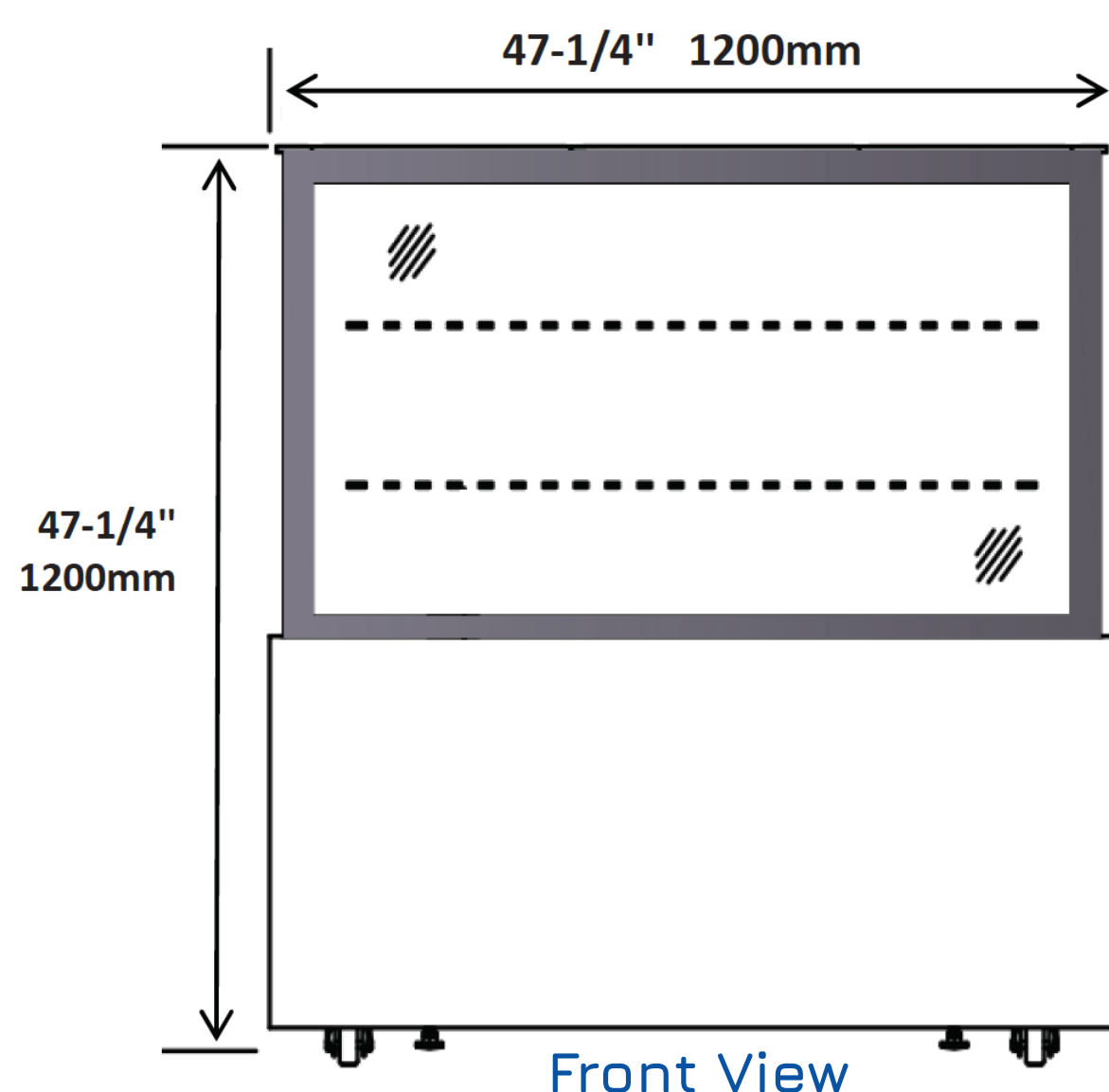

MOTAK reserves the right to make changes to the design or specifications without prior notice.

JAN0621