

MOTAK

Bakery Display Case w/ Straight Glass

Model #: MCD59-2-X

Product Details

- Refrigeration system keeps meats and deli products at safe temperatures between 36°F and 43°F
- Sliding glass doors on staff side
- Adjustable glass shelves provide extra-large viewing area to maximize bakery product presentation
- Made with shatter-resistant tempered glass
- Electronic control system makes it easy to adjust temperature set point and defrost frequency
- Efficient LED interior lighting
- Pre-installed 2" swivel casters
- Eco-friendly R290 refrigerant
- Condenser coil is easy to access for cleaning and service

Not suitable for installation in non-commercial or residential applications.



Warranty

1 year parts & labor and additional 2 years on compressor

Certifications



Specifications

Model	Doors	Shelves	Cabinet Dims (in)			HP	Voltage	Amp	NEMA Plug	Cord Length (ft)	Crated Weight (lbs)
			Width	Depth	Height						
MCD59-2-X	3	2	58.125"	28.75"	47.25"	1/2	115/60/1	9.96	5-15P	10 ft.	506 lbs.

Plan View

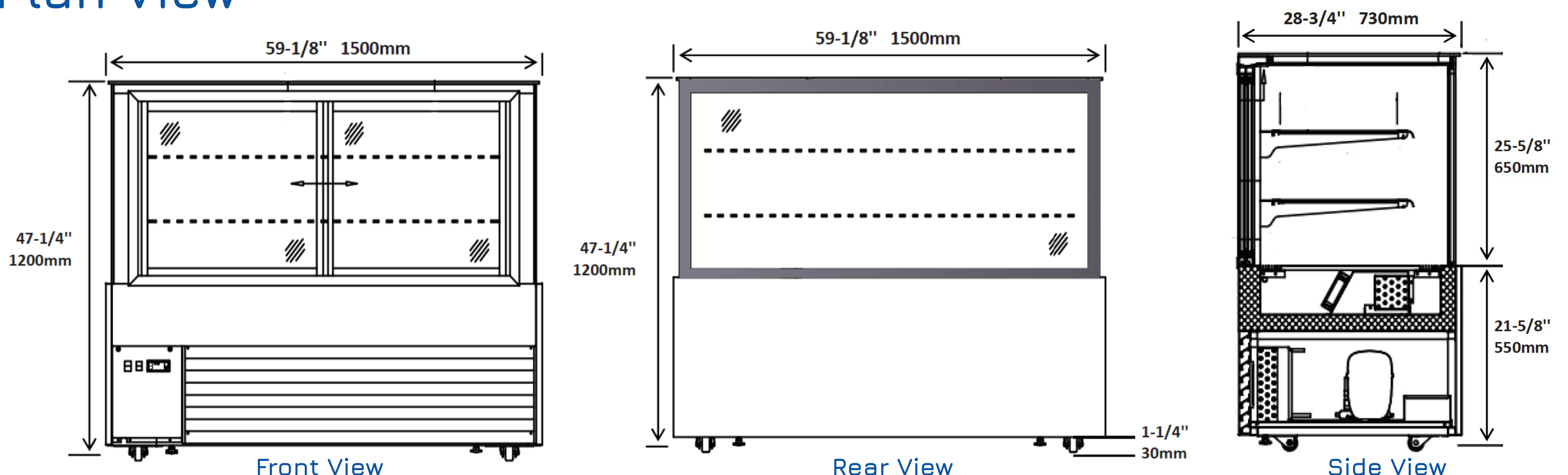

MOTAK reserves the right to make changes to the design or specifications without prior notice.

JAN0621