



HOSHIZAKI

Service Manual

Steelheart Series
Refrigerated Kitchen Equipment

Models
Refrigerated Prep Table with Raised Rail
B Series



hoshizakiamerica.com

Number: 73246
Issued: 2-14-2023
Revised: 2-29-2024

⚠ WARNING

Only qualified service technicians should install and service the appliance. To obtain the name and phone number of your local Hoshizaki Certified Service Representative, visit www.hoshizaki.com. No service should be undertaken until the technician has thoroughly read this Service Manual. Failure to service and maintain the appliance in accordance with this manual will adversely affect safety, performance, component life, and warranty coverage. Proper installation is the responsibility of the installer. Product failure or property damage due to improper installation is not covered under warranty.

Hoshizaki provides this manual primarily to assist qualified service technicians in the service of the appliance.

Should the reader have any questions or concerns which have not been satisfactorily addressed, please call, send an e-mail message, or write to the Hoshizaki Technical Support Department for assistance.

Phone: 1-800-233-1940; (770) 487-2331

Fax: 1-800-843-1056; (770) 487-3360

E-mail: techsupport@hoshizaki.com

HOSHIZAKI AMERICA, INC.

618 Highway 74 South

Peachtree City, GA 30269

Attn: Hoshizaki Technical Support Department

Web Site: www.hoshizaki.com

NOTE: To expedite assistance, all correspondence/communication **MUST** include the following information:

- Model Number _____
- Serial Number _____
- Complete and detailed explanation of the problem.

IMPORTANT

This manual should be read carefully before the appliance is serviced. Read the warnings and guidelines contained in this booklet carefully as they provide essential information for the continued safe use, service, and maintenance of the appliance. Retain this booklet for any further reference that may be necessary.

CONTENTS

Important Safety Information	4
I. Construction and Refrigeration Circuit Diagram	8
A. Construction	8
B. Refrigeration Circuit Diagram	9
II. Sequence of Operation and Service Diagnosis	10
A. Sequence of Operation Flow Chart	10
B. Service Diagnosis	12
C. Thermistor Check	19
D. Diagnostic Table	20
III. Controls and Adjustments	22
A. Control Modules	23
B. Temperature	26
1. Default Temperature Settings	26
2. Temperature Setpoint	26
3. Adjusting the Temperature Setpoint for Rail Area Cooling	26
4a. Cabinet Temperature Control - Cabinet Control Module 4A7178-01	27
4b. Cabinet Temperature Control - Cabinet Control Module 4A7053-01	29
C. Manual Defrost	31
D. Cabinet Control Alarm Safeties	31
1a. Cabinet Control Module: 4A7178-01	31
1b. Cabinet Control Module: 4A7053-01	32
E. Safety Devices	32
IV. Refrigeration Circuit and Component Service Information	33
A. Refrigeration Circuit Service Information	35
1. Refrigerant Recovery	35
2. Brazing	36
3. Evacuation	37
B. Component Service Information	38
V. Maintenance	39
VI. Preparing the Appliance for Periods of Non-Use	40
VII. Disposal	41
VIII. Technical Information	42
A. Electrical and Refrigerant Data	42
B. Wiring Diagrams	43

Important Safety Information

Throughout this manual, notices appear to bring your attention to situations which could result in death, serious injury, damage to the appliance, or damage to property.

⚠ DANGER	Indicates a hazardous situation that, if not avoided, will result in death or serious injury.
⚠ WARNING	Indicates a hazardous situation that, if not avoided, could result in death or serious injury.
NOTICE	Indicates a situation that, if not avoided, could result in damage to the appliance or property.
IMPORTANT	Indicates important information about the use and care of the appliance.

⚠ DANGER

Risk of Fire or Explosion

Flammable Refrigerant Used

- Follow handling instructions carefully in compliance with U.S. government regulations.
- Do not use mechanical devices to defrost.
- Do not puncture refrigerant tubing. Risk of fire or explosion due to puncture of refrigerant tubing; follow handling instructions carefully.
- Component parts shall be replaced with like components.
- Servicing shall be done by factory authorized service personnel to minimize the risk of possible ignition due to incorrect parts or improper service.
- Consult instruction manual / service manual before attempting to install or service this product. All safety precautions must be followed.
- Dispose of properly in accordance with federal or local regulations.
- Do not place any potential ignition sources in or near the appliance.

Risque De Feu Ou D'Explosion

Le Frigorigène Est Inflammable

- Suivre attentivement les instructions de manipulation conformément à la réglementation gouvernementale.
- Ne pas utiliser d'appareils mécaniques pour dégivrer le réfrigérateur.
- Ne pas perforer la tubulure contenant le frigorigène. Risque de feu ou d'explosion si la tubulure contenant le frigorigène est perforée; suivre les instructions de manutention avec soin.
- Les pièces des composants doivent être remplacées par des pièces et accessoires équivalents.
- L'entretien doit être effectué par le personnel de service autorisé par le fabricant afin de minimiser les risques d'inflammation attribuables à l'installation d'une pièce inadéquate ou à la mauvaise exécution du service.
- Consulter le manuel du propriétaire/ guide de réparation avant de tenter une réparation. Toutes les mesures de sécurité doivent être respectées.
- Éliminer conformément aux règlements fédéraux ou locaux.
- Ne placez aucune source d'inflammation potentielle dans ou près de l'appareil.

WARNING

The appliance should be destined only to the use for which it has been expressly conceived. Any other use should be considered improper and therefore dangerous. The manufacturer cannot be held responsible for injury or damage resulting from improper, incorrect, and unreasonable use. Failure to install, operate, and maintain the appliance in accordance with this manual will adversely affect safety, performance, component life, and warranty coverage.

To reduce the risk of death, electric shock, serious injury, or fire, follow basic precautions including the following:

- Only qualified service technicians should install and service the appliance.
- Wear appropriate personal protective equipment (PPE) when servicing the appliance.
- The appliance must be installed in accordance with applicable national, state, and local codes and regulations.
- Appliance is heavy. Use care when lifting or positioning. Work in pairs when needed to prevent injury or damage. Do not lift using the top section or the doors/drawers.
- To reduce the risk of electric shock, do not touch the plug with damp hands.
- Unplug the appliance before servicing.
- The appliance requires an independent power supply of proper capacity. See the nameplate for electrical specifications. Failure to use an independent power supply of proper capacity can result in a tripped breaker, blown fuse, damage to existing wiring, or component failure. This could lead to heat generation or fire.

• **THE APPLIANCE MUST BE**

GROUNDING. The appliance is equipped with a NEMA 5-15 three-prong grounding plug  to reduce the risk of potential shock hazards. It must be plugged into a properly grounded, independent 3-prong wall outlet. If the outlet is a 2-prong outlet, it is your personal responsibility to have a qualified electrician replace it with a properly grounded, independent 3-prong wall outlet. Do not remove the ground prong from the power cord and do not use an adapter plug. Failure to follow these instructions may result in death, electric shock, or fire.

- Do not use an extension cord.
- Do not use an appliance with a damaged power cord. The power cord should not be altered, jerked, bundled, weighed down, pinched, or tangled. Such actions could result in electric shock or fire. To unplug the appliance, be sure to pull the plug, not the cord, and do not jerk the cord.
- The GREEN ground wire in the factory installed power cord is connected to the appliance. If it becomes necessary to remove or replace the power cord, be sure to connect the power cord's ground wire.
- Do not splash, pour, or spray water directly onto or into the appliance. This might cause short circuit, electric shock, corrosion, or failure.
- Do not make any alterations to the appliance. Alterations could result in electric shock, injury, fire, or damage to the appliance.
- The appliance is not intended for use by persons (including children) with reduced physical, sensory, or mental capabilities, or lack of experience and knowledge, unless they have been given supervision or instruction concerning use of the appliance by a person responsible for their safety.

⚠ WARNING, continued

- Children should be properly supervised around the appliance.
- Do not climb, stand, or hang on the appliance or doors/drawers or allow children or animals to do so. Do not climb into the appliance or allow children or animals to do so. Death or serious injury could occur or the appliance could be damaged.
- Be careful not to pinch fingers when opening and closing the doors/drawers or rail cover or when handling food pans. Be careful when opening and closing the doors/drawers or rail cover when children are in the area.
- Open and close the doors/drawers and rail cover with care. Opening the doors/drawers or rail cover too quickly or forcefully may cause injury or damage to the appliance or surrounding equipment.
- Do not use combustible spray or place volatile or flammable substances in or near the appliance. They might catch fire.
- Keep the area around the appliance clean. Dirt, dust, or insects in the appliance could cause harm to individuals or damage to the equipment.
- Do not throw anything onto the shelves or load any single shelf with more than 120 lb. (54.5 kg) of product. They might fall off and cause injury.
- Do not load any single drawer with more than 150 lb. (68 kg) of product. Depending on the weight of product in the drawers, secure the appliance as necessary to prevent it from overturning. Do not open more than one drawer at a time.
- The appliance is designed only for temporary storage of food. Employ sanitary methods. Use for any other purposes (for example, storage of chemicals or medical supplies such as vaccine and serum) could cause deterioration of stored items.

- Do not block air inlets or outlets, otherwise cooling performance may be reduced.
- Do not tightly pack the cabinet. Allow some space between items to ensure good air flow. Also allow space between items and interior surfaces.
- Do not put warm or hot foods in the cabinet. Let them cool first, or they will raise the cabinet temperature and could deteriorate other foods in the cabinet or overload the appliance.
- Food storage and handling must comply with applicable codes and regulations.
- All foods should be wrapped in plastic film or stored in sealed containers. Otherwise foods may dry up, pass their smells onto other foods, cause frost to develop, result in poor appliance performance, or increase the likelihood of cross-contamination. Certain dressings and food ingredients, if not stored in sealed containers, may accelerate corrosion of the evaporator, resulting in failure.
- Do not store items near air outlets. Otherwise, items may freeze up and crack or break causing a risk of injury or contamination of other food.
- The entire rail must always be covered by rail dividers and pans. Otherwise, the appliance will not cool properly. Use only pans up to 6" (15 cm) deep. Do not use damaged rail dividers or pans.
- Ingredients must be pre-chilled to 37°F (3°C) or less before placing in rail.
- The rail is for keeping ingredients cool while preparing food. If not actively preparing food for a long period such as overnight, seal pans with plastic wrap in addition to closing the rail cover.
- For PR46-D2 models, all 6 casters must be installed. Otherwise, the appliance may tip, resulting in injury or damage.

NOTICE

- Protect the floor when moving the appliance to prevent damage to the floor.
- Keep ventilation openings clear of obstruction. The factory-installed rear bumpers must be in place to ensure proper rear clearance. Blockage of airflow could negatively affect performance and damage the appliance.
- Do not allow the appliance to bear any outside weight.
- To prevent deformation or cracks, do not spray insecticide onto the plastic parts or let them come into contact with oil.
- To avoid damage to the gasket, use only the door/drawer handle when opening and closing.
- Do not leave the doors/drawers open.
- To avoid damage to the top seal, do not lift the appliance by the top panel or remove the top panel.
- Do not place anything on top of the rail hood or rail cover and do not lift the appliance by the rail hood or rail cover. The rail hood and rail cover are not designed to bear any outside weight.
- Do not place anything on the air duct panel beneath the pans in the rail. The air duct panel is not load-bearing.

I. Construction and Refrigeration Circuit Diagram

A. Construction

1. Refrigerated Prep Table with Raised Rail

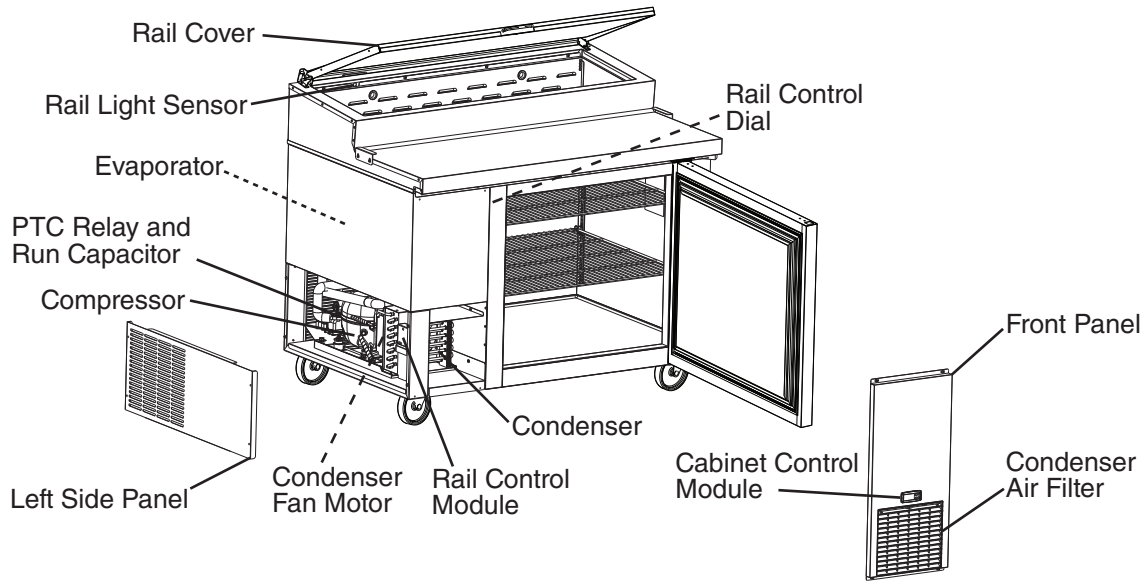

Model Shown: PR46B

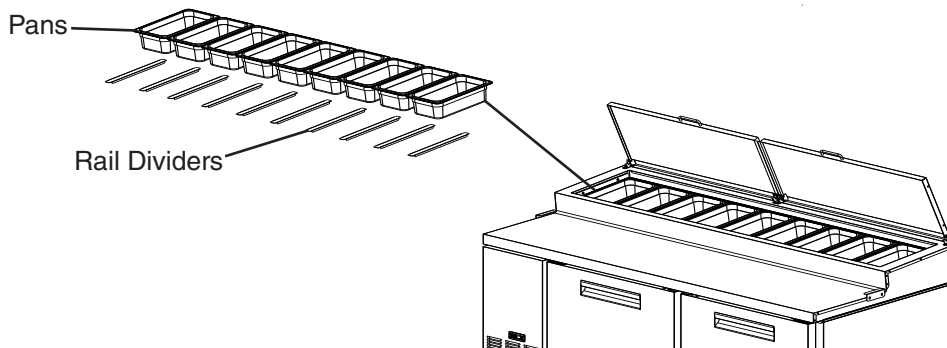

Model Shown: PR67B

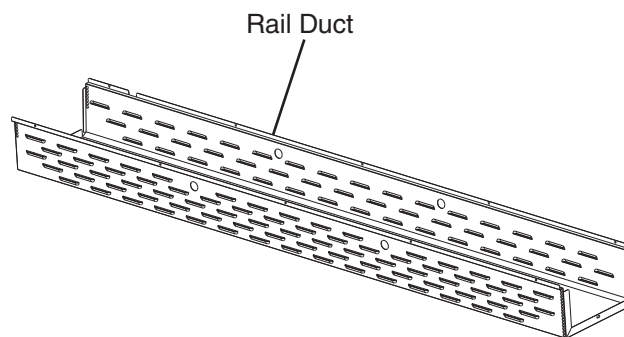

Model Shown: PR93B

B. Refrigeration Circuit Diagram

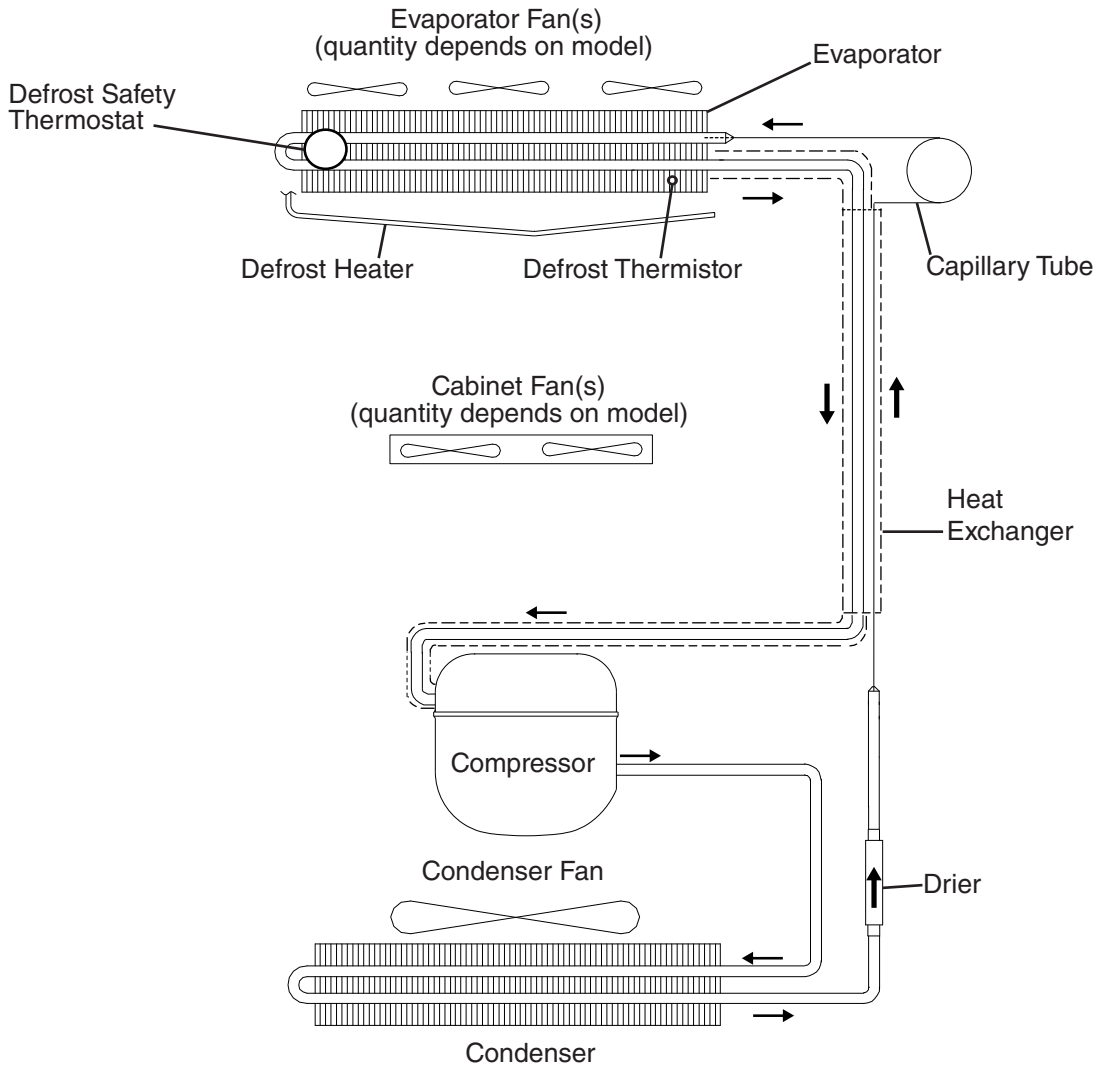

II. Sequence of Operation and Service Diagnosis

A. Sequence of Operation Flow Chart

1. Rail Sequence

Rail Sequence Flow Chart

Day and Night Mode

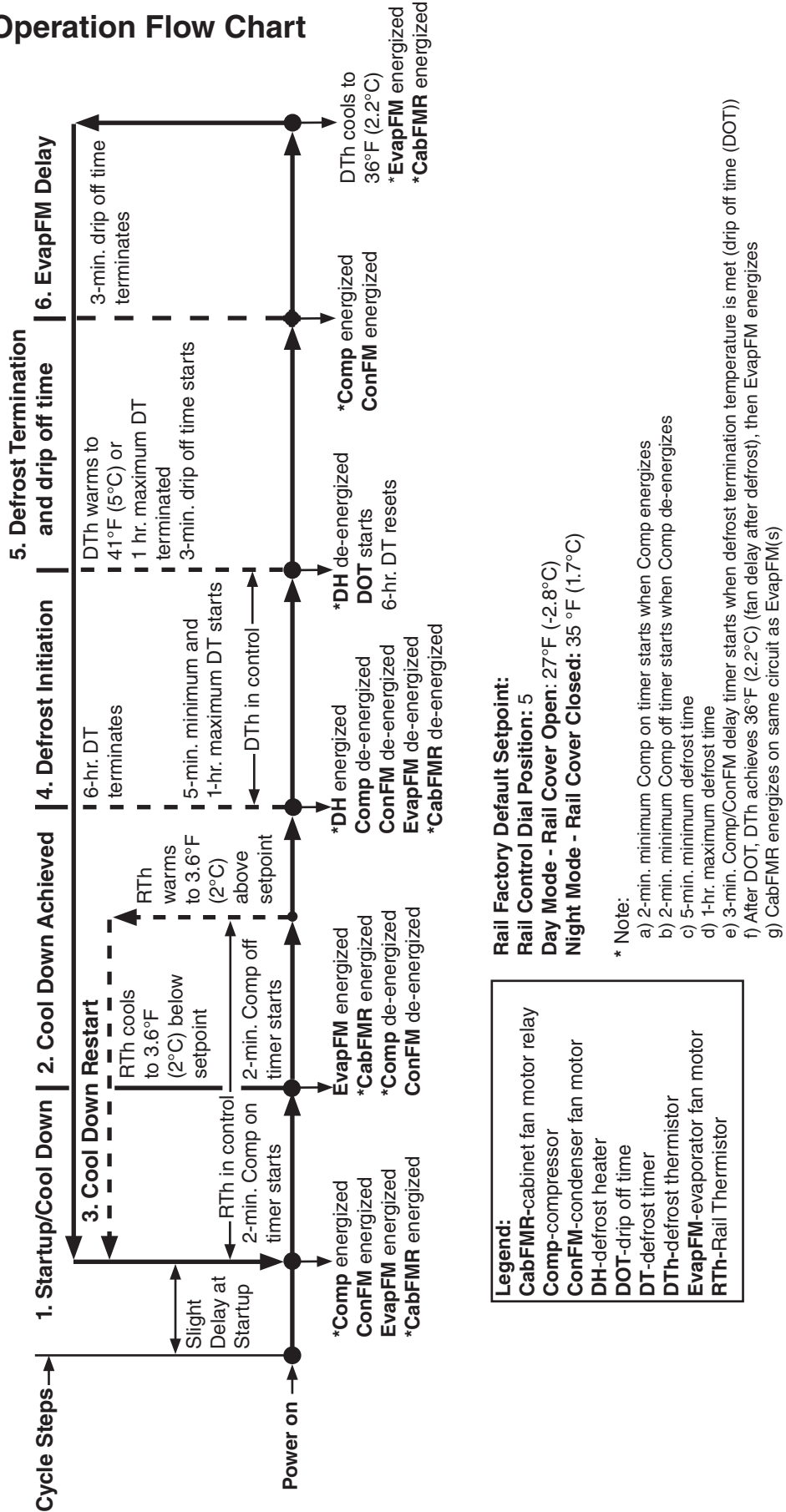

Rail Factory Default Setpoint:

Rail Control Dial Position: 5

Day Mode - Rail Cover Open: 27°F (-2.8°C)

Night Mode - Rail Cover Closed: 35 °F (1.7°C)

*** Note:**

- 2-min. minimum Comp on timer starts when Comp energizes
- 2-min. minimum Comp off timer starts when Comp de-energizes
- 5-min. minimum defrost time
- 1-hr. maximum defrost time
- 3-min. Comp/ConFM delay timer starts when defrost termination temperature is met (drip off time (DOT))
- After DOT, DTh achieves 36°F (2.2°C) (fan delay after defrost), then EvapFM energizes
- CabFMR energizes on same circuit as EvapFM(s)

Legend:

- CabFMR-cabinet fan motor relay
- Comp-compressor
- ConFM-condenser fan motor
- DH-defrost heater
- DOT-drip off time
- DT-defrost timer
- DTh-defrost thermistor
- EvapFM-evaporator fan motor
- RTh-Rail Thermistor

2. Cabinet Sequence

Cabinet Sequence Flow Chart

Cabinet Fan Motor(s) relay energized through rail control module

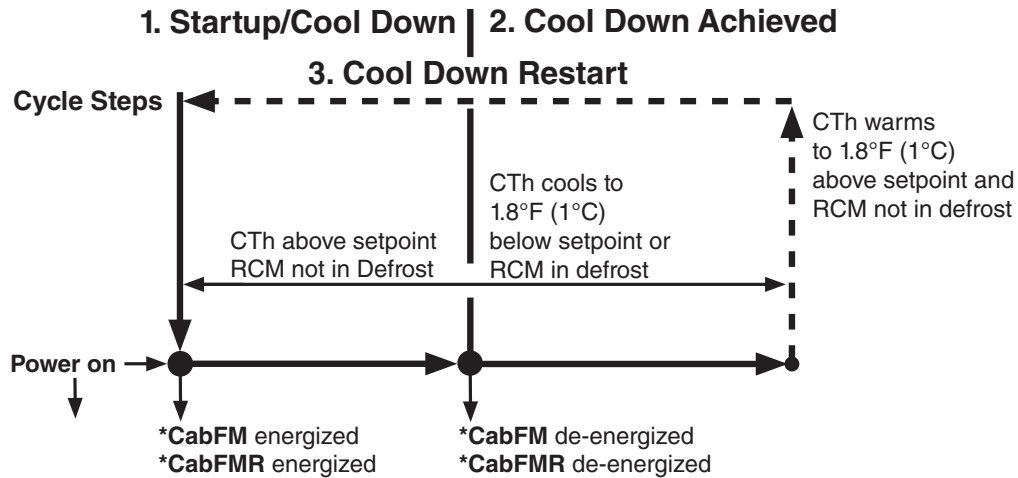

Legend:
CabFM-cabinet fan motor
CabFMR-cabinet fan motor relay
CCM-cabinet control module
CTh-cabinet thermistor
RCM-rail control module

Cabinet Factory Default Setpoint:
Cabinet Control Module: 35°F (1.7°C)

*Note:

- RCM de-energizes CabFMR when rail is in defrost.
- CabFM(s) are energized when the CCM cooling icon is on and CabFMR is energized. The cooling icon represents a call for cooling from the CTh. When displayed, CCM provides 115VAC to CabFMR for CabFM operation. CabFMR only energizes when EvapFM(s) are energized through the RCM. The CCM cooling icon may be on when the CabFMR is not energized due to the appliance being in defrost.

B. Service Diagnosis

DANGER

Risk of Fire or Explosion

Flammable Refrigerant Used

- Follow handling instructions carefully in compliance with U.S. government regulations.
- Do not use mechanical devices to defrost.
- Do not puncture refrigerant tubing. Risk of fire or explosion due to puncture of refrigerant tubing; follow handling instructions carefully.
- Component parts shall be replaced with like components.
- Servicing shall be done by factory authorized service personnel to minimize the risk of possible ignition due to incorrect parts or improper service.
- Consult instruction manual/service manual before attempting to install or service this product. All safety precautions must be followed.
- Dispose of properly in accordance with federal or local regulations.
- Do not place any potential ignition sources in or near the appliance.

Risque De Feu Ou D'Explosion

Le Frigorigène Est Inflammable

- Suivre attentivement les instructions de manipulation conformément à la réglementation gouvernementale.
- Ne pas utiliser d'appareils mécaniques pour dégivrer le réfrigérateur.
- Ne pas perforer la tubulure contenant le frigorigène. Risque de feu ou d'explosion si la tubulure contenant le frigorigène est perforée; suivre les instructions de manutention avec soin.
- Les pièces des composants doivent être remplacées par des pièces et accessoires équivalents.
- L'entretien doit être effectué par le personnel de service autorisé par le fabricant afin de minimiser les risques d'inflammation attribuables à l'installation d'une pièce inadéquate ou à la mauvaise exécution du service.
- Consulter le manuel du propriétaire/ guide de réparation avant de tenter une réparation. Toutes les mesures de sécurité doivent être respectées.
- Éliminer conformément aux règlements fédéraux ou locaux.
- Ne placez aucune source d'inflammation potentielle dans ou près de l'appareil.

⚠ WARNING

- The appliance should be diagnosed and repaired only by qualified service personnel to reduce the risk of death, electric shock, serious injury, or fire.
- Wear appropriate personal protective equipment (PPE) when servicing the appliance.
- Risk of electric shock. Use extreme caution and exercise safe electrical practices.
- Moving parts (e.g., fan blade) can crush and cut. Keep hands clear.
- Appliance is heavy. Use care when lifting or positioning. Work in pairs when needed to prevent injury or damage.
- Make sure all food zones are clean after the appliance is serviced.

NOTICE

- The appliance is not intended for outdoor use.
- The appliance must not be located in a corrosive environment.
- Normal operating ambient temperature must be within: 45°F to 86°F (7°C to 30°C)
- The appliance must not be located next to ovens, grills, or other high heat producing equipment.
- The appliance must be a minimum of 1" (3 cm) from side walls.
- The factory-installed rear bumpers must be in place to ensure proper rear clearance.
- A minimum of 10" (25 cm) clearance above the rail must be provided to allow the rail cover to open.

The diagnostic procedure is a sequence check that allows you to diagnose the electrical system and components. Before proceeding, check for correct installation and proper voltage per nameplate.

Note: When checking voltage (115VAC), always choose a white (W) neutral wire to establish a good neutral connection.

Factory Default Temperature Settings:

- a) Rail Control Dial: 5
Day Mode - Rail Cover(s) Open (27°F (-2.8°C))
Night Mode - Rail Cover(s) Closed (35°F (1.7°C))
- b) Cabinet Control Module: 35°F (1.7°C)
- c) Display Scale: °F

Note: There is a minimum 2-min. Comp on time and 2-min. Comp off time.
For further details, see "III. Controls and Adjustments."

- 1) Unplug the appliance from the electrical outlet.
- 2) Remove the front panel and left side panel.
- 3) Plug the appliance back into the electrical outlet. 6-hr. defrost timer starts.

- 4) **Startup/Cool Down** – Rail and cabinet temperature above setpoint. RCD, RTh and CTh are calling for cooling. Comp, ConFM, EvapFM(s), CabFM(s) and CabFMR energize. Cabinet temperature and cooling icon are displayed on the CCM.
- a) **RTh, RCD, and RCM Diagnosis:** Day Mode: With rail cover(s) open and RTh calling for cooling, Comp, ConFM, EvapFM(s), and CabFMR energize. If not, confirm that the RCD is in the correct setting position (5). Next, check the resistance between RCD red and black wires. Resistance value should be between 3.76-5.64K ohm. If RCD is out of range, replace RCD. If RCD is in range and rail temperature is above setpoint, check RTh. See "II.C. Thermistor Check." If RTh is out of range, replace RTh. If RTh is in range, check for 115VAC at RCM line 2(L) black (BK) wire to RCM neutral 3(N) white (W) wire . If 115VAC is not present, check breaker/fuse for an open circuit. Reset or replace as needed. Check for loose connections on line 2(L) black (BK) wire and neutral 3(N) white (W) wire and power cord connections. If 115VAC is present at RCM 2(L) black (BK) wire and neutral 3(N) white (W) wire, check for 115VAC at RCM 1(C) violet (V) wire to RCM neutral 3(N) white (W) wire. If 115VAC is not present, replace RCM.
- b) **Comp/ConFM Diagnosis:** Comp and ConFM energize. If not, confirm 115VAC at RCM 1(C) violet (V) wire. Next, check for 115VAC from both sides of Comp external protector red (R) wire and Comp terminal to neutral (W) wire. If 115VAC is present on one side and not the other, allow time for Comp external protector to cool and reset. If Comp external protector does not reset, replace Comp external protector. If 115VAC is present on both Comp external protector connections (red (R) wire and Comp terminal) to neutral white (W), check Comp run capacitor, PTC relay, and Comp motor windings. Replace as needed. If ConFM is not energized, check ConFM fan blades for binding and motor winding continuity.
- c) **EvapFM and CabFMR Diagnosis:** EvapFM(s) and CabFMR energize. If EvapFM(s) do not energize, check for 115VAC at RCM 5(F) dark blue (DBU) wire to neutral white (W) wire. If 115VAC is not present and Comp and ConFM are energized, replace RCM. If 115VAC is present, check EvapFM(s) blades for binding and EvapFM(s) continuity. If defective, replace EvapFM(s). Confirm 115VAC at CabFMR dark blue (DBU) wire to neutral white (W) wire. If 115VAC is not present, check wiring from RCM.

d1) Service Diagnosis: Cabinet Control Module: 4A7178-01

PR46B: L-5 to M50052H, M50073K and Later; (-D2): ALL

PR60B: L-5 to M50007H, M50025L and Later; (-D2)(-D4): ALL

PR67B(-D2)(-D4): ALL

PR93B(-D2)(-D4)(-D6): ALL

CCM, CTh, CabFMR, and CabFM Diagnosis:

CCM and CTh Diagnosis: Cabinet temperature appears on display and when cabinet temperature is above setpoint, cooling icon (❄️) is displayed. If the cabinet temperature is not displayed, check for 115VAC at CCM line 8(L) black (BK) wire to 7(N) neutral white (W) wire. If 115VAC is not present, check power cord connections and breaker/fuse. Reset or replace breaker/fuse (if applicable). If 115VAC is present and display is off, replace CCM. If 115VAC is present and the cabinet temperature is displayed and cabinet temperature is above setpoint, cooling icon (❄️) is displayed. If not check CTh. See "II.C. Thermistor Check 5) b)." If CTh is out of range, replace the CTh. If CTh is in range, cabinet temperature is above setpoint, and cooling icon is not displayed, replace CCM.

CabFMR and CabFM Diagnosis: With CCM cooling icon displayed (❄️) (represents CTh call for cooling) and CabFMR energized, CabFM(s) energize. If not, check for 115VAC at CCM 3(F) yellow (Y) wire to 7(N) neutral white (W) wire. If 115VAC is not present, replace CCM. If 115VAC is present, confirm 115VAC at CabFMR dark blue (DBU) wire to neutral white (W) wire. If 115VAC is not present, check RCM. See "a) RTH, RCD, and RCM Diagnosis." If 115VAC is present, check for 115VAC at CabFMR white/blue (W/BU) wire. If 115VAC is not present, replace CabFMR. Next, check for CabFM(s) fan blade binding and continuity of CabFM(s) windings. If defective, replace CabFM(s).

d2) Service Diagnosis: Cabinet Control Module: 4A7053-01

PR46B: M50053H-M50072H

PR60B: M50008H-M50024H

CCM, CTh, CabFMR, and CabFM Diagnosis:

CCM and CTh Diagnosis: Cabinet temperature appears on display and when cabinet temperature is above setpoint, cooling icon (❄️) is displayed. If the temperature is not displayed, check for 115VAC at CCM line 2(L) black (BK) wire to 3(N) neutral white (W) wire. If 115VAC is not present, check power cord connections and breaker/fuse. Reset or replace breaker/fuse (if applicable). If 115VAC is present and display is off, replace CCM. If 115VAC is present and cabinet temperature is above setpoint, cooling icon (❄️) is displayed. If not, check CTh. See "II.C. Thermistor Check 5) a)." If CTh is out of range, replace CTh. If CTh is in range, cabinet temperature is above setpoint, and cooling icon is not displayed, replace CCM.

CabFMR and CabFM Diagnosis: With CCM cooling icon displayed (❄️) (represents CTh call for cooling) and CabFMR energized, CabFM(s) energize. If not, check for 115VAC at CCM 1(DO1) yellow (Y) wire and 3(N) neutral white (W) wire. If 115VAC is not present, replace CCM. If 115VAC is present, confirm 115VAC at CabFMR dark blue (DBU) wire to neutral white (W) wire. If 115VAC is not present, check RCM status for call for cooling. See "a) RTH, RCD, and RCM Diagnosis". If 115VAC is present, check for 115VAC at CabFMR white/blue (W/BU) wire. If 115VAC is not present, replace CabFMR. Next, check for CabFM(s) fan blade binding and continuity of CabFM(s) windings. If defective, replace CabFM(s).

- 5) **Rail Day Mode or Night Mode Cool Down Achieved** – RTh cools to 3.6°F (2°C) below setpoint. Comp, ConFM, EvapFM(s), and CabFMR de-energize.
Diagnosis: Confirm Comp and ConFM de-energize. If not, and Comp and ConFM were energized longer than 2 min., check RTh status. See "II.C. Thermistor Check." If RTh is good and Comp and ConFM were energized longer than 2 min., check for 115VAC at RCM 1(C) violet (V) wire to neutral 3(N) white (W) wire. If 115VAC is present, replace RCM.
- 6) **RLSen Diagnosis** – Day mode or night mode confirmation. Check RCM 0VDC and 5VDC output voltage to RLSen. **Note:** Small accessory type wires with exposed ends are needed to access the RCM RLSen connections for VDC readings. Due to different levels of light intensity luminance levels, the RCM VDC output reading for the RLSen during day mode (rail cover(s) open) may vary between 0-3VDC.
Day Mode: Open the rail cover(s) exposing the RLSen to light.
Next, check between RCM S4 blue (BU) wire to RCM S4 brown (BR) wire for 0-3VDC. If 5VDC is present, replace RLSen.
Night mode: Close the rail cover(s) removing light exposure to the RLSen.
Next, check between RCM S4 blue (BU) wire to RCM S4 brown (BR) wire for 5VDC. If 0-3VDC is present, replace RLSen.
- 7) **Cabinet Cool Down Achieved** – CTh cools to 1.8°F (1°C) below setpoint 35°F (1.7°C). CabFM(s) de-energize. **Diagnosis:** CabFM(s) de-energize. If not, check CTh status. See "II.C. Thermistor Check." If CTh is good, check for 115VAC at CCM 3(F) yellow (Y) wire to neutral 7(N) white (W) wire. If 115VAC is present, replace CCM.
- 8) **Defrost** – 6-hr. time/temperature defrost initiation terminates, defrost starts. If energized, Comp, ConFM, EvapFM(s), CabFMR, CabFM(s) de-energize. DH energizes. There is a 5-min. minimum defrost time, 1-hr. maximum defrost time, 6-hr. minimum and maximum defrost interval.
 - 1a) **Time/Temperature Initiation:** 6-hr. time/temperature defrost initiation terminates, defrost starts. Comp, ConFM, EvapFM(s), CabFMR, CabFM(s) de-energize. DH energizes.

- 1b) **Manual-Initiation:** To initiate or terminate a manual defrost cycle: Turn the rail control dial clockwise to put the rail control dial 9 setting in the 12 o'clock position, pause for 3 to 5 sec., then turn the rail control dial counterclockwise to any position below setting 7 in the 12 o'clock position. Defrost initiates or terminates within 5 sec. **Note:** When defrost is manually initiated it continues through the normal defrost cycle unless manually terminated. Compressor must be on for a minimum of 2 min. to initiate defrost and off for a minimum of 2 min. to terminate defrost.

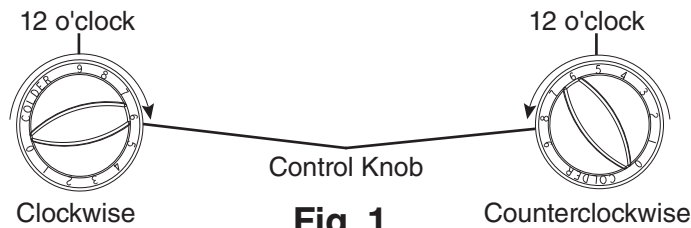

2) **Defrost-Termination:**

- (1) DTh warms to 41°F (5°C). DH de-energizes. 3-min. drip off time starts.
- (2) 3-min. drip off time terminates. Comp and ConFM energize. If DTh is at 36°F (2.2°C) or lower, EvapFM/CabFM(s) energize. 6-hr. defrost interval timer resets. Note: If DTh is 37°F (3°C) or higher when 3-min. drip off time terminates, EvapFM/CabFM(s) remain off until DTh is 36°F (2.2°C) or lower.

Defrost Diagnosis:

- 1a) **Defrost Time/Temperature Initiation Diagnosis:** 6-hr. defrost timer terminates. RCM checks DTh status. If DTh is at or below 41°F (5°C), defrost starts. Comp, ConFM, EvapFM(s), CabFMR and CabFM(s) de-energize. If 6-hr. defrost timer terminates and defrost does not start, check DTh. See "II.C. Thermistor Check." Replace if needed. If DTh is at or below 41°F (5°C) and defrost does not start, replace RCM. If DTh is at or above 42°F (5.5°C), RCM continues in cooling mode.
- 1b) **Defrost Manual-Initiation Diagnosis:** Turn the rail control dial clockwise to put the rail control dial 9 setting in the 12 o'clock position, pause for 3 to 5 sec., then turn the rail control dial counterclockwise to any position below rail control dial setting 7 in the 12 o'clock position. Defrost initiates or terminates within 5 sec. If not, replace RCM and RCD.

Note: Compressor must be on for a minimum of 2 min. to initiate defrost and off for a minimum of 2 min. to terminate defrost.

Check the following:

- (1) **DH Diagnosis:** Confirm DH energizes. If not, check for 115VAC at RCM 4(H) red (R) wire to neutral white (W) wire. If 115VAC is not present, replace RCM. If 115VAC is present, check continuity of DST. If open, let cool and reset. If DST does not close, replace DST. If DST is closed, check DH amp draw and continuity. Replace if necessary.
- (2) **Comp and ConFM Diagnosis:** Confirm Comp and ConFM de-energize. If not, check for 115VAC at RCM 1(C) violet (V) wire to neutral white (W) wire. If 115VAC is present, replace RCM.
- (3) **RCM and CabFMR Diagnosis:** Confirm EvapFM(s), CabFMR, and CabFM(s) de-energize. If not, check for 115VAC at RCM 5(F) dark blue (DBU) wire to neutral white (W) wire. If 115VAC is present, replace RCM. If 115VAC is not present and CabFM(s) continue, check for 115VAC at CabFMR white/blue (W/DBU) wire to neutral white (W) wire. If 115VAC is present (cooling icon on), replace CabFMR.

- 2) **Termination Diagnosis:** There is a 5 min. minimum defrost time and a 1 hr. maximum defrost time. Has 5-min. minimum defrost timer terminated? Confirm DTh status. See "II.C. Thermistor Check."
- (1) **RCM, DTh, and DH Diagnosis:** If 5-min. minimum defrost timer has terminated, has DTh warmed to 41°F (5°C)? If not, check DST and DH continuity. Next, check DH amp draw. If DTh is in proper range, DH de-energizes. If not, replace RCM. If 41°F (5°C) is not achieved within 1 hr., RCM terminates defrost. Once DH de-energizes or 1-hr. maximum defrost timer terminates, 3-min. drip off time starts. (confirm)
 - (2) **Comp/CondFM, EvapFM Diagnosis:** 3-min. drip off time terminates. Comp, ConFM energize. If DTh is 37°F (2.8°C) or higher when 3-min. drip off time terminates, EvapFM(s) remains off until DTh is 36°F (2.2°C) or lower. If not, confirm RTh is warm enough for Comp, ConFM, and EvapFM(s) operation. Next, check for 115VAC at RCM 1(C) violet (V) wire to neutral white (W) wire. If 115VAC is not present, check RTh status. "II.C. Thermistor Check." If RTh ohm reading is in proper range and Comp and ConFM do not energize, replace RCM. If 115VAC is present and Comp does not energize, check Comp external overload. If open, let it cool and reset. If it does not reset, replace external overload. If closed, check PTC relay, run capacitor, Comp windings for continuity, or motor binding. If ConFM is not energized, check ConFM fan blades for binding and winding continuity.
 - (3) **EvapFM Diagnosis:** 3-min. Comp/ConFM drip off time terminates. If DTh is at 36°F (2.2°C) or lower, EvapFM energizes. If not, confirm that DTh is at 36°F (2.2°C) or lower. If not, confirm Comp is on and cooling. See "II.B.5)b) Comp/ConFM Diagnosis" and "II.C. Thermistor Check." Once 36°F (2.2°C) or lower is achieved, check for 115VAC at RCM 5(F) dark blue (DBU) wire to neutral white (W) wire. If 115VAC is not present, replace RCM. If 115VAC is present, and EvapFM(s) are not energized, check EvapFM(s) blades for binding and EvapFM(s) windings continuity.
 - (4) **CabFM Diagnosis:** 3-min. drip off time terminates. If DTh is at 36°F (2.2°C) or lower, CabFMR energizes. If not, check for 115VAC at CabFMR dark blue (DBU) wire to neutral (W) wire. If 115VAC is not present and DTh is at 36°F (2.2°C) or lower, replace RCM. If 115VAC is present and CabFM(s) are not energized, check for 115VAC at CabFMR yellow (Y) wire to neutral white (W) wire. If 115VAC is not present, check temperature at CTh. CabFM(s) de-energize when CTh is below CCM setpoint. Once CTh temperature reaches 1.8°F (1°C) above setpoint, check for 115VAC at CCM 3(F) yellow (Y) wire to neutral white (W) wire. If 115V is not present, replace CCM. If 115VAC is present and CabFM(s) are not energized, check CabFM(s) blades for binding and CabFM(s) winding continuity. If there is no continuity, replace CabFM(s).

Legend: **CabFM**—cabinet fan motor; **CabFMR**—cabinet fan motor relay; **CCM**—cabinet control module; **Comp**—compressor; **ConFM**—condenser fan motor; **CTh**—cabinet thermistor; **DH**—defrost heater; **DST**—defrost safety thermostat; **DTh**—defrost thermistor; **EvapFM**—evaporator fan motors; **RCD**—rail control dial; **RCM**—rail control module; **RLSen**—rail light sensor; **RTh**—rail thermistor

C. Thermistor Check

This appliance utilizes 3 thermistors: Rail thermistor, cabinet thermistor, and defrost thermistor. The rail thermistor is used for rail temperature control, the cabinet thermistor is used for cabinet temperature control and the defrost thermistor is used for defrost termination (41°F (5°C)). The defrost thermistor is also used for evaporator fan motor/ cabinet fan motor initiation after defrost (36°F (2.2°C) or lower). Thermistor resistance varies depending on temperature. The rail control module monitors the rail and defrost thermistors, while the cabinet control module monitors the cabinet thermistor.

To check thermistor resistance, follow the steps below.

- 1) Unplug the appliance.
- 2) Remove the front panel.
- 3) Disconnect and remove the thermistor in question.
- 4) Immerse the thermistor sensor portion in a glass containing ice and water for 2 to 3 min.
- 5) Check the resistance between the wires at the thermistor connector. If outside the normal reading, replace the thermistor.

Cabinet Control Module: 4A7178-01

PR46B: L-5 to M50052H, M50073K and Later; (-D2): ALL

PR60B: L-5 to M50007H, M50025L and Later; (-D2)(-D4): ALL

PR67B(-D2)(-D4): ALL

PR93B(-D2)(-D4)(-D6): ALL

- a) **Cabinet Thermistor** - 25 to 27 kΩ

Rail Control Module: 4A5948-01

PR46B: L-5 to M50052H, M50073K and Later; (-D2): ALL

PR60B: L-5 to M50007H, M50025L and Later; (-D2)(-D4): ALL

PR67B(-D2)(-D4): ALL

PR93B(-D2)(-D4)(-D6): ALL

- b) **Rail and Defrost Thermistor** - 16 to 16.7 kΩ

Cabinet Control Module: 4A7053-01

PR46B: M50053H-M50072H

PR60B: M50008H-M50024H

- c) **Rail , Cabinet, and Defrost Thermistor** - 16 to 16.7 kΩ

- 6) Reconnect and replace the thermistor in its correct position.
- 7) Plug the appliance back in.

D. Diagnostic Table

Check for correct appliance installation per the instruction manual and proper voltage per appliance nameplate.

1a. Appliance Not Cooling - Rail Area

Appliance Not Cooling - Rail Area - Possible Cause	
1. Power Supply	a) Unplugged, blown fuse, or tripped or defective circuit breaker.
	b) Loose connection.
	c) Not within specifications.
2. Power Cord and Plug	a) Loose connection.
	b) Defective.
3. Wiring	a) Loose connection or open.
	b) Faulty.
4. Rail Control Module	a) In alarm (LED flashing red).
	b) In defrost.
	c) Defective.
5. Rail Control Dial	a) Set too warm.
	b) Defective.
6. Rail Thermistor See "II.C. Thermistor Check"	a) Loose, disconnected, or out of position.
	b) Defective.
7. Rail Light Sensor	a) Defective. Stuck in night mode while rail lids open (Day mode). See "II.B.6. RLSen Diagnosis."
8. Compressor External Protector	a) Dirty condenser.
	b) Condenser fan motor not operating.
	c) Defective.
	d) PTC relay defective.
	e) Low charge.
	f) Run capacitor (if applicable) defective.
9. Compressor	a) Defective.
10. Condenser Fan Motor	a) Fan blade binding.
	b) Defective.
11. Condenser	a) Dirty.
12. Evaporator Fan Motor	a) Defective.
	b) Fan Blade Binding.
13. Evaporator	a) Dirty or frozen up. See "II.D.2. Evaporator is Frozen Up."
14. Refrigerant/Refrigerant Lines	a) Gas leak.
	a) Refrigerant lines or components restricted.
15. Rail Air Duct Panel	a) Misaligned or missing.
16. Pans and Rail Dividers	a) Misaligned with gaps in the rail area.
17. Defrost Heater	a) Rail Control Module defective.

1b. Appliance Not Cooling - Cabinet Area

Appliance Not Cooling - Cabinet Area - Possible Cause	
1. Power Supply	a) Unplugged, blown fuse, or tripped or defective circuit breaker.
	b) Loose connection.
	c) Not within specifications.
2. Power Cord and Plug	a) Loose connection.
	b) Defective.
3. Wiring	a) Loose connection or open.
	b) Faulty.
4. Cabinet Control Module See "III.D. Alarm Safeties."	a) Loose connection.
	b) In alarm.
	c) Defective.
5. Cabinet Thermistor	a) Loose, disconnected, or defective.
6. Cabinet Fan Motor	a) Loose connection.
	b) Defective.
	c) Cabinet Control Module defective.
7. Cabinet Fan Motor Relay	a) Loose connection.
	b) Defective.
8. Doors/Drawers/Gaskets	a) Open/Not sealing.

2. Evaporator is Frozen Up - Possible Cause

Evaporator is Frozen Up	
1. Evaporator	a) Dirty.
2. Evaporator Fan Motor	a) Defective.
	b) Fan blade binding.
	c) Defrost thermistor defective.
	d) Rail control module defective.
3. Rail Control Module	a) Defective. 6-hr. defrost timer or 4-hr. continuous compressor run timer fails to initiate defrost.
4. Rail Light Sensor	a) Incorrect position.
	b) Defective. Stuck in day mode while rail lids closed (Night mode).
5. Refrigerant Charge/Refrigerant Lines	a) Low.
	b) Component restriction (cap tube, drier).
6. Defrost Heater	a) Defective.
7. Defrost Safety Thermostat	a) Defective.
8. Doors/Drawers/Gaskets	a) Open/Not sealing.

3. Defrost Fails to Initiate or Terminate - Possible Cause

Defrost Fails to Initiate	
1. Rail Control Module	a) Defective.
Defrost Fails to Terminate	
1. Defrost Thermistor (Confirm DTh status. See "II.C. Thermistor Check.")	a) Defective.
2. Rail Control Module	a) Defective.

III. Controls and Adjustments

This appliance utilizes a rail control module, rail control dial, rail light sensor, and a cabinet control module. See Fig. 2.

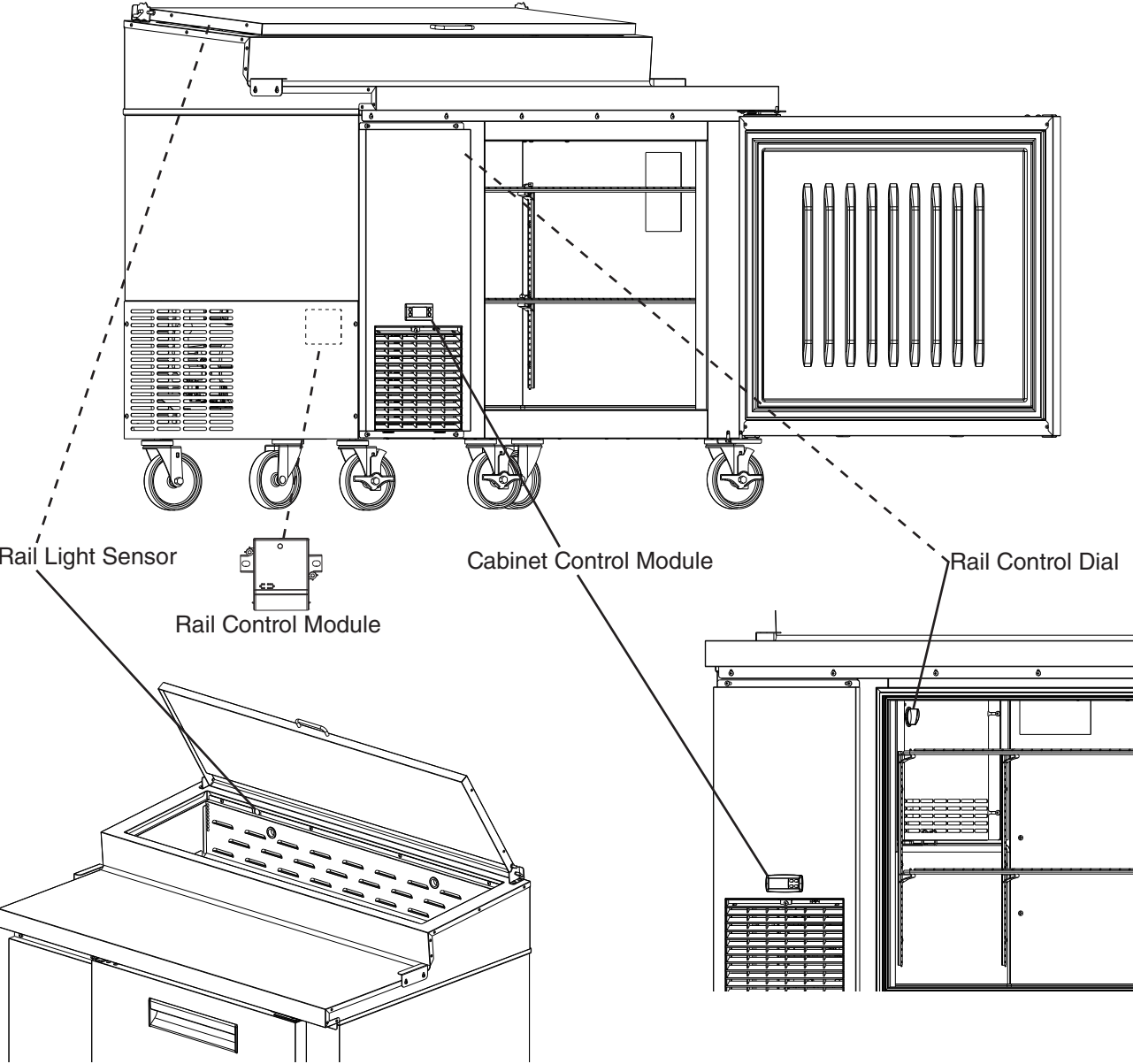

Fig. 2

A. Control Modules

When the power cord is plugged in there is a slight delay, then the current cabinet temperature is displayed on the cabinet control module. From the cabinet control module, the cabinet setpoint and temperature display scale can be changed.

All models are pretested and factory set.

NOTICE

- The control modules are fragile, handle very carefully.
- Do not change wiring and connections. Never misconnect terminals.
- Do not short out power supply to test for voltage.

1. Rail Control Dial and Rail Control Module

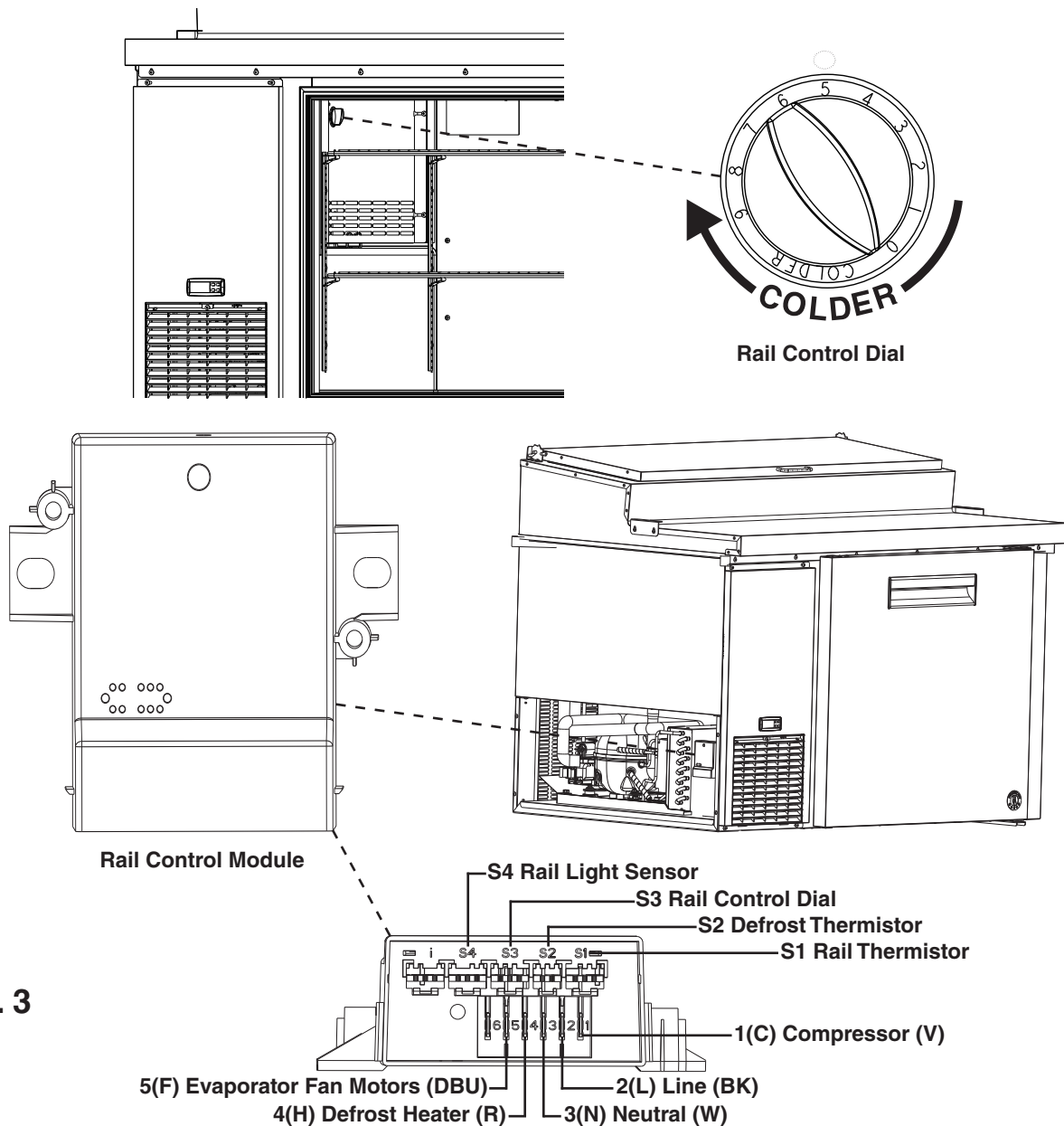



Fig. 3

- 2a. Cabinet Control Module Display Icons: 4A7178-01**
PR46B: L-5 to M50052H, M50073K and Later; (-D2): ALL
PR60B: L-5 to M50007H, M50025L and Later; (-D2)(-D4): ALL
PR67B(-D2)(-D4): ALL
PR93B(-D2)(-D4)(-D6): ALL

Cabinet Control Module Icons	
Icon	Meaning
	Cooling Icon used for Cabinet Fan Motor operation Cabinet thermistor calling for cooling. Cabinet fan motor energized if compressor is energized.
	Alarm for Cabinet Appliance is in alarm. See "III.D. Alarm Safeties" for details.

a) Cabinet Control Module 4A7178-01 Display Layout
Cabinet Control Module

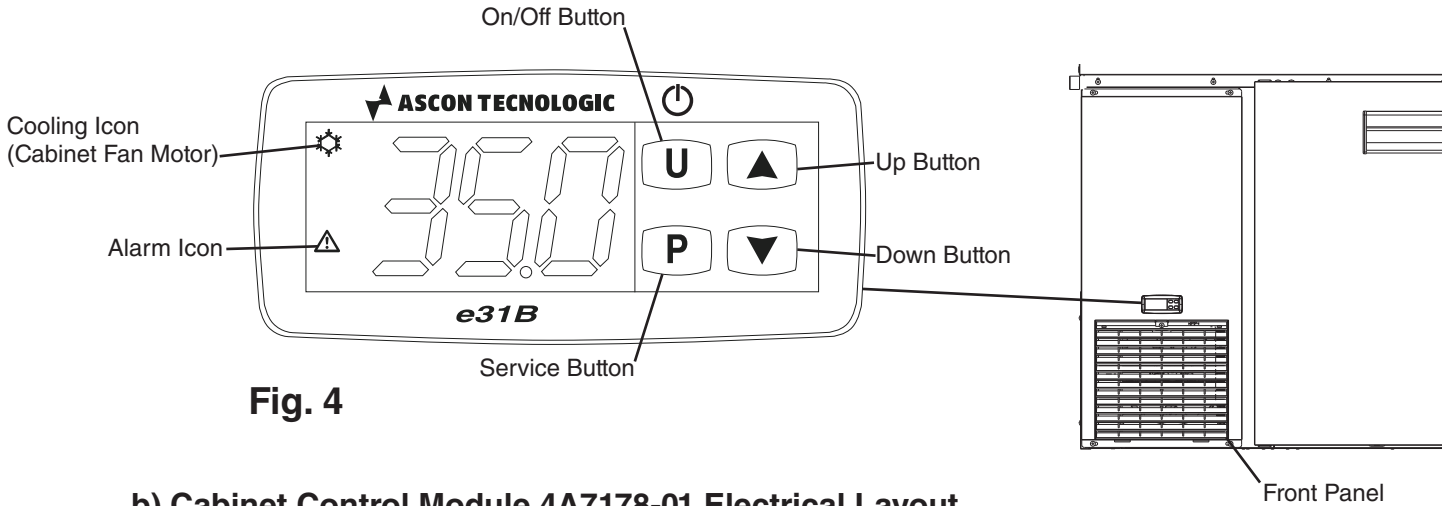

Fig. 4

b) Cabinet Control Module 4A7178-01 Electrical Layout
Cabinet Control Module

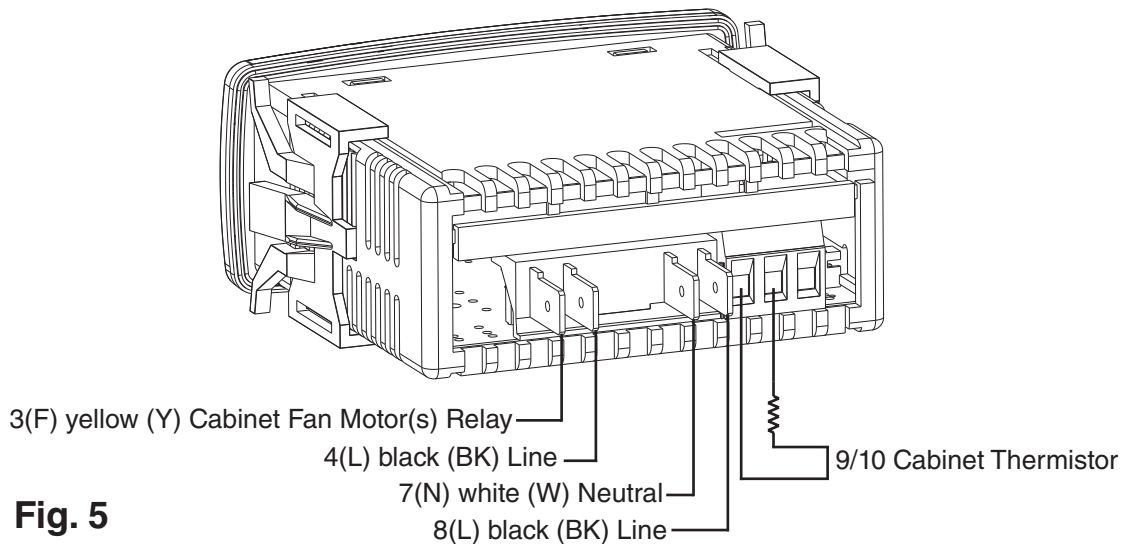



Fig. 5

2b. Cabinet Control Module Display Icons: 4A7053-01

PR46B: M50053H-M50072H

PR60B: M50008H-M50024H

Cabinet Control Module Icons	
Icon	Meaning
	Cooling Icon used for Cabinet Fan Motor operation Cabinet thermistor calling for cooling. Cabinet fan motor energized if compressor is energized.
	Alarm for Cabinet Appliance is in alarm. See "III.D. Alarm Safeties" for details.

a) Cabinet Control Module 4A7053-01 Display Layout

Cabinet Control Module

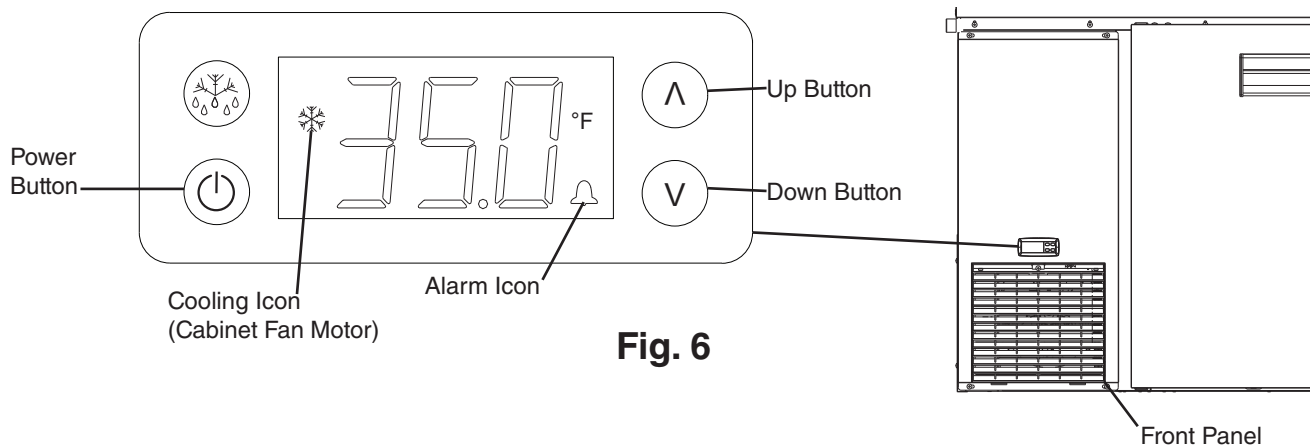

Fig. 6

b) Cabinet Control Module 4A7053-01 Electrical Layout

Cabinet Control Module

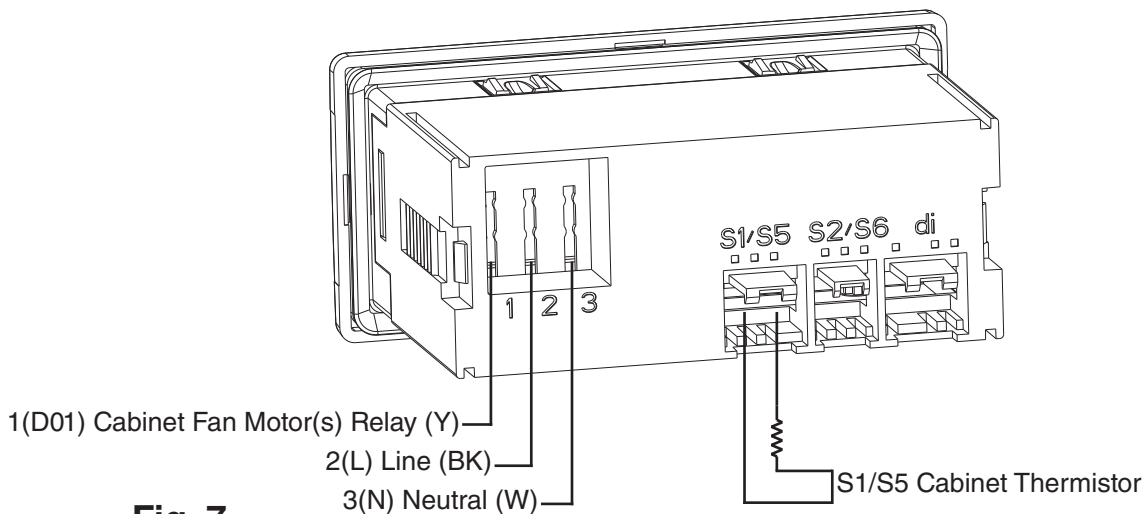

Fig. 7

B. Temperature

The default temperature scale is °F, but it can be changed to read °C. To change, see "III.B.3. Changing the Temperature Display Scale (°F or °C)."

1. Default Temperature Settings

- a) Rail Area Day Mode (Rail Cover Open) - Rail Control Dial Setpoint: 5 (27°F (-2.8°C)).
- b) Rail Area Night Mode (Rail Cover Closed) - Rail Control Dial Setpoint: 5 (35°F (1.7°C)).
- c) Cabinet Control Module Setpoint: 35°F (1.7°C).
- d) Temperature Display Scale: °F.

2. Temperature Setpoint

The temperature setpoint is the value for the average temperature of the rail or cabinet. During Rail Day Mode, the temperature differential for the compressor (Rail Control Dial) to turn on and off, is $\pm 3.6^{\circ}\text{F}$ ($\pm 2^{\circ}\text{C}$) of the temperature setpoint. For example, for a temperature setpoint of 27°F (-2.8°C), the compressor comes on at 30.6°F (-1°C), and the compressor goes off at 23.4°F (-5°C). During Rail Night Mode, the temperature differential is a set temperature of 8°F above the Rail Control Dial setpoint.

The temperature for the Cabinet fan motor (Cabinet Control Module) to turn on and off, is $\pm 1.8^{\circ}\text{F}$ (1°C) of the temperature setpoint. For example, for a temperature setpoint of 35°F (1.7°C), the cabinet fan motor comes on at 36.8°F (2.7°C) and the cabinet fan motor goes off at 33.2°F (0.7°C) of the temperature setpoint.

Control	Adjustable Temperature Setpoint
Rail Control Dial	18° to 36°F (-7.8° to 2.2°C)
Cabinet Control Module	28° to 40°F (-2.2° to 4.4°C)

NOTICE! Do not adjust the temperature setpoint more than 2°F (1°C) at a time. Allow the temperature to stabilize for a minimum of 8 hrs. before making further temperature setpoint adjustments.

3. Adjusting the Temperature Setpoint for Rail Area Cooling

This appliance utilizes 2 controls to control the temperature in the rail area: The rail control dial and the rail light sensor. The rail light sensor communicates to the rail control module whether the rail cover is open or closed. When the rail cover is open, the rail is in day mode and the rail control module maintains setpoint using the rail control dial. When the rail cover is closed, the rail is in night mode and the rail control module maintains an 8°F (4.4°C) setpoint above the day mode rail control dial setting. See next page for details.

- a) **Rail Control Dial Adjustment.** To adjust day mode temperature setpoint, rotate the control knob counterclockwise for a warmer setting and clockwise for a colder setting. See Fig. 8. 1 is the warmest setting and 9 is the coldest setting. For "OFF" position, rotate to 0 setting. Note: The factory default setting is position 5 on the rail control dial (27°F (-2.8°C)). There is a 2.25°F (1.25°C) difference between each number setting on the control knob. Night mode is a programmed temperature offset of 8°F (4.4°C) above the day mode rail control dial setting. **NOTICE! The rail control dial, in conjunction with the rail control module, controls compressor operation. Cabinet fan motor operation is controlled by rail control module, cabinet fan motor relay, and the cabinet control module.**

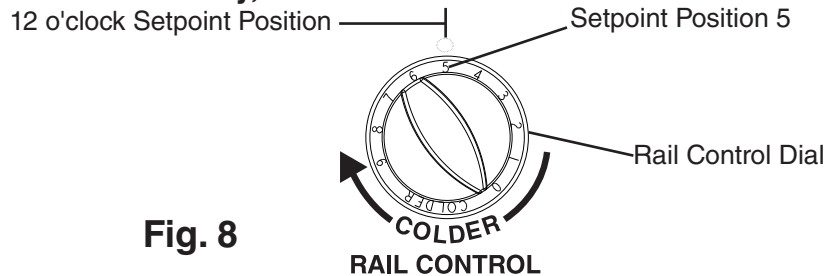

Fig. 8

- b) **Rail Cover Open; Day Mode:** With the rail cover open, day mode engages. The rail light sensor communicates with the rail control module to maintain the setpoint of the rail control dial in conjunction with the rail thermistor.
- c) **Rail Cover Closed; Night Mode:** When the rail cover closes, there is a 10 min. delay for night mode to engage. The rail light sensor communicates with the rail control module in conjunction with the rail thermistor to maintain offset rail setpoint for night time storage of product in the rail area.

WARNING! To prevent night time mode from engaging during day time mode operation, make sure the rail light sensor remains clean and not obstructed.

4a. Cabinet Temperature Control - Cabinet Control Module 4A7178-01

PR46B: L-5 to M50052H, M50073K and Later; (-D2): ALL

PR60B: L-5 to M50007H, M50025L and Later; (-D2)(-D4): ALL

PR67B(-D2)(-D4): ALL

PR93B(-D2)(-D4)(-D6): ALL

The cabinet temperature is controlled by the cabinet control module in conjunction with the cabinet thermistor and cabinet fan motor relay. The cabinet control module energizes the cabinet fan motors when needed, if cabinet fan motor relay is energized. The cabinet control module does not energize or de-energize the compressor.

WARNING! Adjusting cabinet setpoint only affects cabinet fan motors operation. It does not control compressor operation.

- a) **Cabinet Temperature Setpoint Adjustment:** The cabinet temperature is displayed on the cabinet control module. To change the cabinet setpoint, press the up arrow and release. See Fig. 9. SP1 and the current cabinet setpoint flashes. Press the up or down arrow button to the desired setpoint. 5-sec. later, the setpoint is saved and the display returns to normal.

NOTICE! Do not adjust the setpoint more than 2°F (1°C) at a time. Allow the temperature to stabilize for a minimum of 8 hours before making further temperature setpoint adjustments.

b) Cabinet Temperature Display Scale (°F or °C):

There are 4 temperature display settings from which to choose.

The factory temperature display default is F0 for °F whole number.

For a whole number temperature display scale value, select F0 or C0.

For a temperature display scale value to one decimal point, select F1 or C1.

Display Scale	Temperature Display Style
F0 - Factory Default	35°F
C0	2°C
F1	35.0°F
C1	2.0°C

To change the temperature display scale, follow the steps below.

- 1) Press and hold both the "U" and "P" buttons for 5 seconds, μ .P is displayed.
- 2) Press the "P" button. The current display setting (F0, F1, C0 or C1) and μ .P start flashing.
- 3) Press the up or down button until the desired temperature display style is displayed.
- 4) Press the "P" button to save the selection. μ .P is displayed. To return to normal display mode, press and hold the "U" button for 5 sec. Display returns to normal display mode. If no other button is pressed after pressing the "P" button, 25 sec. later, display returns to normal display mode.

Note: If no selection is saved within 30 seconds, the display returns to normal mode and the temperature display scale remains unchanged.

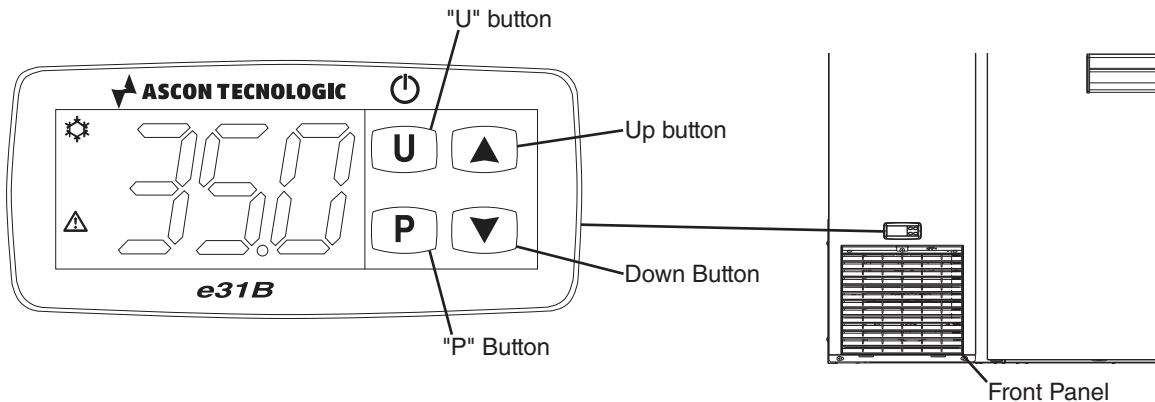

Fig. 9

4b. Cabinet Temperature Control - Cabinet Control Module 4A7053-01

PR46B: M50053H-M50072H

PR60B: M50008H-M50024H

The cabinet temperature is controlled by the cabinet control module in conjunction with the cabinet thermistor and cabinet fan motor relay. The cabinet control module energizes the cabinet fan motors when needed, if cabinet fan motor relay is energized. The cabinet control module does not energize or de-energize the compressor.

WARNING! Adjusting cabinet setpoint only affects cabinet fan motor(s) operation. It does not control compressor operation.

- a) **Cabinet Temperature Setpoint Adjustment:** The cabinet temperature is displayed on the cabinet control module. To change the cabinet setpoint, press the up or down arrow button and release. See Fig. 10. The current cabinet setting flashes. Press the up or down arrow button to the desired setpoint. 5-sec. later, the setpoint is saved and the display returns to normal display.

NOTICE! Do not adjust the setpoint more than 2°F (1°C) at a time. Allow the temperature to stabilize for a minimum of 8 hours before making further temperature setpoint adjustments.

b) **Cabinet Temperature Display Scale (°F or °C):**

To change the temperature display scale, follow the steps below.

- 1) Press and hold both the up and down buttons for 5 seconds, "EHE" is displayed.
- 2) Press the up or down arrow button until "diS" is displayed.
- 3) Press the power button, "din" is displayed. Press the up or down arrow until "CFu" is displayed. Press power button, current temperature display scale flashes. Press up or down arrow to select between "-F" or "-C".
- 4) Press the power button to save the selection. "CFu" is displayed. To return to normal display mode, wait 1 min. or press the back button twice to return to temperature display.

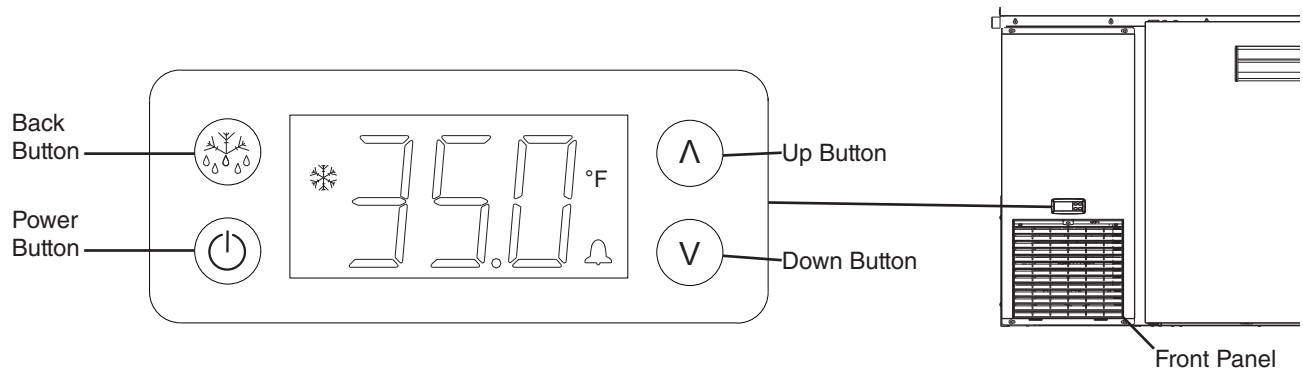

Fig. 10

c) Cabinet Temperature Display Scale Value (35°F/C or 35.0°F/C):

To change the temperature display scale value from a whole number to one decimal point, follow the steps below.

- 1) Press and hold both the up and down buttons for 5 seconds, "EHE" is displayed.
- 2) Press the up or down arrow button until "diS" is displayed.
- 3) Press the up or down arrow button until "rES" is displayed. Press the power button, current setting is displayed.
- 4) Select between 3 settings -
 - a) 1.0 - Setting will show temperature rounded to the nearest whole number degree.
 - b) 0.5 - Setting will show temperature rounded to the nearest half number degree.
 - c) 0.1 - Setting will show temperature as decimal degree, no rounding occurs.
- 5) Press the power button to save desired selection, "rES" is displayed. To return to normal display mode, wait 1 min. or press the back button twice to return to temperature display.

Note: If no selection is saved within 30 seconds, the display returns to normal mode and display remains unchanged.

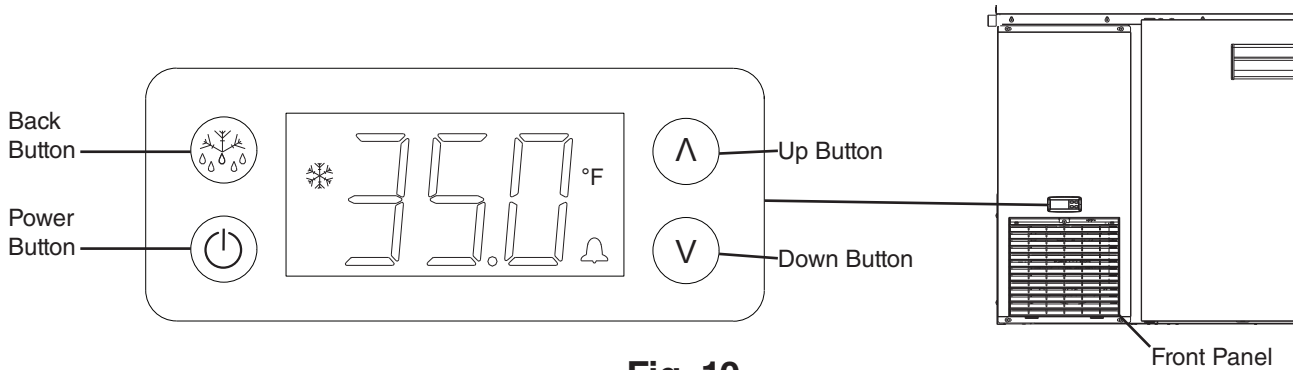
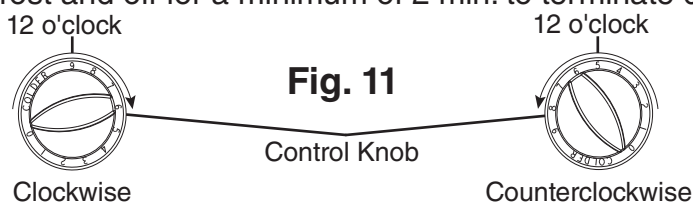

Fig. 10

C. Manual Defrost

The cabinet control module does not have the function enabled for manual defrost. The rail control dial is used for this function. To manually initiate or terminate a defrost cycle: Turn the rail control dial clockwise to put the control dial 9 setting in the 12 o'clock position, pause for 3 to 5 sec., then turn the rail control dial counterclockwise to any position below setting 7 in the 12 o'clock position. Defrost initiates or terminates within 5 sec. See Fig.11.

Note: When defrost is manually initiated, it continues through the normal defrost cycle unless manually terminated. Compressor must be on for a minimum of 2 min. to initiate defrost and off for a minimum of 2 min. to terminate defrost.



D. Cabinet Control Alarm Safeties

1a. Cabinet Control Module: 4A7178-01

PR46B: L-5 to M50052H, M50073K and Later; (-D2): ALL

PR60B: L-5 to M50007H, M50025L and Later; (-D2)(-D4): ALL

PR67B(-D2)(-D4): ALL

PR93B(-D2)(-D4)(-D6): ALL

These alarms give information in the event the cabinet area is operating out of acceptable parameters. Should one of the alarms occur, follow the instructions in the table below to address the alarm. The alarm code and alarm icon flash with audible alarm. To silence the alarm, press and release any button.

Alarm Signals		
Alarm Code	Problem	Corrective Action/Reset Details
(-)E1	Cabinet Thermistor Malfunction Alarm Cabinet thermistor has failed.	Check Cabinet Thermistor. Steady tone. To silence the alarm, press and release any button. Cabinet Fan(s) cycle 5 min. on, 5 min. off. -E1 - Cabinet thermistor out of place or open. E1 - Cabinet thermistor shorted.
Hi	High Temperature Alarm Cabinet temperature has remained above 57°F (13.9°C) for more than 1 hour.	Check for open doors/drawers, dirty air filter and/or condenser. Steady tone. To silence the alarm, press and release any button. The alarm icon stays on. Automatically resets when temperature returns to normal.
Lo	Low Temperature Alarm Cabinet temperature has remained below 20°F (-6.6°C) for more than 1 hour.	Check Rail Control Module, Rail Thermistor, and Rail Light Sensor. Steady tone. To silence the alarm, press and release any button. The alarm icon stays on. Automatically resets when temperature returns to normal.

1b. Cabinet Control Module: 4A7053-01

PR46B: M50053H-M50072H

PR60B: M50008H-M50024H

Alarm Signals		
Alarm Code	Problem	Corrective Action/Reset Details
E01	Cabinet Thermistor Malfunction Alarm Cabinet thermistor has failed.	Check Cabinet Thermistor. "E01" flashes. Alarm icon flashes. Cabinet Fan(s) cycle 5 min. on, 5 min. off. E01 - Cabinet thermistor out of place, open or shorted.
Hi	High Temperature Alarm Cabinet temperature has remained above 57°F (13.9°C) for more than 1 hour.	Check for open doors/drawers, dirty air filter and/or condenser. "Hi" and temperature alternates flashing. Alarm icon flashes. Automatically resets when temperature returns to normal.
Lo	Low Temperature Alarm Cabinet temperature has remained below 20°F (-6.6°C) for more than 1 hour.	Check Rail Control Module, Rail Thermistor, and Rail Light Sensor. "Lo" and temperature alternates flashing. Alarm icon flashes. Automatically resets when temperature returns to normal.

E. Safety Devices

1. Compressor External Protector

If combined temperature/amperage value is above the limit specified by the compressor manufacturer, the compressor external protector operates independently to turn off the compressor. The compressor external protector de-energizes the compressor until the temperature/amperage value returns to an acceptable level.

2. Short-Cycle Protection

There is a 2-min. minimum off-time and on-time for the compressor.

Note: Time may vary with compressor overload activation.

IV. Refrigeration Circuit and Component Service Information

DANGER

Risk of Fire or Explosion Flammable Refrigerant Used

- Follow handling instructions carefully in compliance with U.S. government regulations.
- Do not use mechanical devices to defrost.
- Do not puncture refrigerant tubing. Risk of fire or explosion due to puncture of refrigerant tubing; follow handling instructions carefully.
- Component parts shall be replaced with like components.
- Servicing shall be done by factory authorized service personnel to minimize the risk of possible ignition due to incorrect parts or improper service.
- Consult instruction manual/service manual before attempting to install or service this product.
- Dispose of properly in accordance with federal or local regulations.
- Do not place any potential ignition sources in or near the appliance.

Risque De Feu Ou D'Explosion Le Frigorigène Est Inflammable

- Suivre attentivement les instructions de manipulation conformément à la réglementation gouvernementale.
- Ne pas utiliser d'appareils mécaniques pour dégivrer le réfrigérateur.
- Ne pas perforer la tubulure contenant le frigorigène. Risque de feu ou d'explosion si la tubulure contenant le frigorigène est perforée; suivre les instructions de manutention avec soin.
- Les pièces des composants doivent être remplacées par des pièces et accessoires équivalents.
- L'entretien doit être effectué par le personnel de service autorisé par le fabricant afin de minimiser les risques d'inflammation attribuables à l'installation d'une pièce inadéquate ou à la mauvaise exécution du service.
- Consulter le manuel du propriétaire/guide de réparation avant de tenter une réparation. Toutes les mesures de sécurité doivent être respectées.
- Éliminer conformément aux règlements fédéraux ou locaux.
- Ne placez aucune source d'inflammation potentielle dans ou près de l'appareil.

⚠ WARNING

- Wear appropriate personal protective equipment (PPE) when servicing the appliance.
- Technician must utilize a combustible gas leak detector at all times.
- Notify everyone in the immediate area that you are working with flammable refrigerant.
- Do not work on appliance in a confined space. Confirm area is well ventilated.
- Identify and eliminate all possible ignition points in a 10 ft. (3 m) area around service area.
- Do not use mechanical devices to defrost.
- Use non-sparking tools.
- Class B dry chemical fire extinguisher or equivalent must be available.
- Do not pressurize system above 200 PSIG during leak check procedure or prior to evacuating refrigeration system.
- This appliance should be diagnosed and repaired only by qualified service personnel to reduce the risk of death, electric shock, serious injury, or fire.
- To reduce the risk of electric shock, do not touch the plug with damp hands.
- Unplug the appliance from the electrical outlet before servicing.
- Make sure all food zones in the appliance are clean after the appliance is serviced.

A. Refrigeration Circuit Service Information

⚠ WARNING

- Repairs requiring the refrigeration circuit to be opened must be performed by properly trained and EPA-certified service personnel.
- Use an electronic leak detector or soap bubbles to check for leaks. Add a trace of refrigerant to the system (if using an electronic leak detector), and then raise the pressure using nitrogen gas (190 PSIG). Do not use R-290 as a mixture with pressurized air for leak testing.

NOTICE

- Always recover the refrigerant and store it in an approved container. Do not discharge the refrigerant into the atmosphere.
- Do not leave the system open for longer than 15 min. when replacing or servicing parts. The Polyol Ester (POE) oils used in R-290 appliances can absorb moisture quickly. Therefore it is important to prevent moisture from entering the system when replacing or servicing parts.
- Always install a new drier every time the sealed refrigeration system is opened. Do not replace the drier until all other repair or replacement has been made. Install the new drier with the arrow on the drier in the direction of the refrigerant flow.
- When brazing, protect the drier by using a wet cloth to prevent the drier from overheating. Do not allow the drier to exceed 250°F (121°C).

Refrigerant leaks must be repaired as soon as they are discovered. If not, refrigerant charge should be recovered from the system until the leak can be repaired.

When repairing a leak:

- Repair the leak properly – Remove the refrigerant, examine the leak source, determine the reason for the leak, and carry out the proper course of action.
- Before repairing the leak, ensure that the refrigerant has been recovered and the system purged with nitrogen when brazing.
- Be sure to remove piercing valves attached to the system after repairs are made.

1. Refrigerant Recovery

Using proper refrigerant practices, place piercing valves toward the end (crimped area) of the high and low-side process tubes, then recover the refrigerant into an approved container or device.

2. Brazing

⚠ DANGER

Risk of Fire or Explosion Flammable Refrigerant Used

- Servicing shall be done by factory authorized service personnel to minimize the risk of possible ignition due to incorrect parts or improper service.

Risque De Feu Ou D'Explosion Le Frigorigène Est Inflammable

- L'entretien doit être effectué par le personnel de service autorisé par le fabricant afin de minimiser les risques d'inflammation attribuables à l'installation d'une pièce inadéquate ou à la mauvaise exécution du service.

⚠ WARNING

- Wear appropriate personal protective equipment (PPE) when servicing the appliance.
- You must have a combustible gas leak detector in the immediate work area at all times.
- You must have a Class B chemical fire extinguisher available at all times.
- Notify all persons in the immediate area that you are working with a flammable refrigerant.
- Do not use silver alloy or copper alloy containing arsenic.
- Be sure the area is clear of refrigerant vapor before brazing.

- 1) Prior to brazing, purge with nitrogen gas for 2 min., flowing at a pressure of 3 to 5 PSIG.
WARNING! Purging with nitrogen gas assures all refrigerant has been removed from the refrigeration circuit.
- 2) Braze/repair/replace damaged component or fittings while purging with nitrogen gas, flowing at a pressure of 3 to 5 PSIG.

NOTICE

- Always install a new drier every time the sealed refrigeration system is opened. Do not replace the drier until after all other repair or replacement has been made. Install the new drier with the arrow on the drier in the direction of the refrigerant flow.
- When brazing, protect the drier by using a wet cloth to prevent the drier from overheating. Do not allow the drier to exceed 250°F (121°C).

- 3) Use soap bubbles to check for leaks. Raise the pressure using nitrogen gas (190 PSIG). Do not use any refrigerant as a mixture with pressurized air for leak testing.
- 4) Once leak checking is complete, release the nitrogen gas from the system.

3. Evacuation

- 1) Attach a vacuum pump to the system. Be sure the high-side charging hose is connected to the field-installed high-side access valve.

IMPORTANT

The vacuum level and vacuum pump may be the same as those for current refrigerants. However, the rubber hose and gauge manifold to be used for evacuation and refrigerant charge should be exclusively for POE oils.
--

- 2) Turn on the vacuum pump, then open the high-side valve on the gauge manifold. Never allow the oil in the vacuum pump to flow backwards.
- 3) Allow the vacuum pump to pull down to a 29.9" Hg vacuum. Evacuating period depends on pump capacity.
- 4) Close the high-side valve on the gauge manifold.
- 5) Disconnect the gauge manifold hose from the vacuum pump and attach it to a refrigerant service cylinder. Remember to loosen the connection and purge the air from the hose. See the nameplate for the required refrigerant charge. Hoshizaki recommends only virgin refrigerant or reclaimed refrigerant which meets the requirements of ARI Standard 700 (latest edition) be used.

4. Recharge

- 6) R-290 can be charged in either the liquid or vapor state.
Liquid charge is preferred. If refrigerant charging is done in the liquid state, place the service cylinder on the scales; **if the service cylinder is not equipped with a dip tube, invert the service cylinder, then place it on the scales.** Open the high-side valve on the gauge manifold.
- 7) Allow the system to charge with liquid until the proper charge weight is met.
- 8) Close the high-side valve on the gauge manifold. If charging is complete, skip to step 10.
- 9) If necessary, add any remaining charge to the system through the low-side.
NOTICE! To prevent compressor damage, use a throttling valve or liquid dispensing device to add the remaining liquid charge through the low-side refrigerant access valve with the compressor running. Close the refrigerant cylinder valve and let the low-side refrigerant equalize to the system, then close the low-side manifold gauge. Move the power switch to the "OFF" position (if applicable) or unplug the appliance from the electrical outlet.
- 10) Pinch off (crimp down) the process tubes just below the piercing valves.
- 11) Remove the piercing valves. Cut the process tubes to remove the piercing valve holes then braze the process tubes closed. Note: Be sure there is no refrigerant leak before brazing.
- 12) Use a combustible gas leak detector or soap bubbles to check for leaks again.
- 13) Place red sleeves over the process tubes.
- 14) Plug the appliance back into the electrical outlet.

B. Component Service Information

NOTICE

When replacing a component listed below, see the notes to help ensure proper operation.

Component	Notes
Compressor	Compressor included in condensing unit: PR46B(-D2) and PR60B(-D2)(-D4): 3B0964-01 PR67B(-D2)(-D4) 3B0992-01 PR93B(-D2)(-D4)(-D6): 3B1600-01 Prior to replacing condensing unit, confirm that the PTC relay and external protector are good. WARNING! To reduce the risk of electric shock, be sure to reconnect the compressor's ground wire.

V. Maintenance

⚠ WARNING

- Unplug the appliance before performing maintenance to prevent electric shock or injury by moving parts. To reduce the risk of electric shock, do not touch the plug with damp hands.
- Before performing maintenance, move all foods into another clean refrigerator or freezer.
- Metal edges can cause cuts. Use proper PPE when cleaning.
- Support or remove the rail cover when cleaning. Otherwise, the rail cover could close suddenly and cause injury.
- Do not pour or spray water on or into the appliance.
- The Rail light sensor must be clean. Otherwise, the appliance may not cool properly.

1. Air Filter

Check the air filter at least twice a month. When clogged, use warm water and a neutral cleaner to wash and rinse the filter.

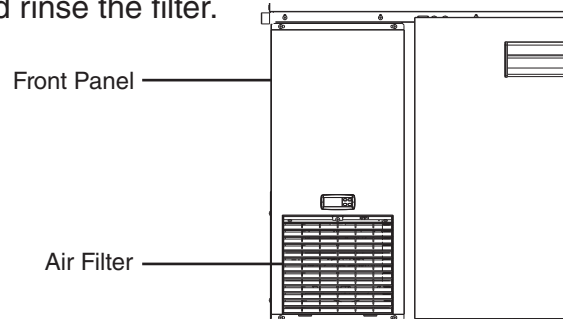

Fig. 12

2. Condenser

Check the condenser once a year and use a brush or vacuum cleaner to clean the condenser as required.

3. Power Supply Connection

If the plug or power cord is damaged, contact your local Hoshizaki service representative or local Hoshizaki distributor immediately and ask for repairs.

All other maintenance or service on this appliance should be performed in accordance with the Hoshizaki Instruction Manual by a qualified service technician.

VI. Preparing the Appliance for Periods of Non-Use

When shutting down the appliance for more than one week, follow the instructions below.

⚠ WARNING

When preparing the appliance for long storage, prevent the doors/drawers from closing to reduce the risk of children getting trapped.

<i>NOTICE</i>

When preparing the appliance for long storage, clean the appliance. See the instruction manual for cleaning details.
--

- 1) Before shutting down the appliance, move all foods into another clean refrigerator or freezer.
- 2) Unplug the appliance. **WARNING! To reduce the risk of electric shock, do not touch the plug with damp hands.**

VII. Disposal

DANGER

Risk of Fire or Explosion Flammable Refrigerant Used

- Follow handling instructions carefully in compliance with U.S. government regulations.
- Do not puncture refrigerant tubing. Risk of fire or explosion due to puncture of refrigerant tubing; follow handling instructions carefully.
- Dispose of properly in accordance with federal or local regulations.

Risque De Feu Ou D'Explosion Le Frigorigène Est Inflammable

- Suivre attentivement les instructions de manipulation conformément à la réglementation gouvernementale.
- Ne pas perforer la tubulure contenant le frigorigène. Risque de feu ou d'explosion si la tubulure contenant le frigorigène est perforée; suivre les instructions de manutention avec soin.
- Éliminer conformément aux règlements fédéraux ou locaux.

WARNING

When preparing the appliance for disposal, remove the doors/drawers to reduce the risk of children getting trapped. Leave any shelves in place so that children may not easily climb inside.

The appliance contains refrigerant and must be disposed of in accordance with applicable national, state, and local codes and regulations. Refrigerant must be recovered by properly certified service personnel.

VIII. Technical Information

A. Electrical and Refrigerant Data

Model	AC Supply Voltage	Amperes	Design Pressure (PSIG)		Refrigerant (oz.)
			HIGH	LOW	R-290
PR46B(-D2)	115/60/1	4.0	360	190	2.4
PR60B(-D2)(-D4)	115/60/1	4.0	360	190	2.4
PR67B(-D2)(-D4)	115/60/1	6.0	360	190	2.7
PR93B(-D2)(-D4)(-D6)	115/60/1	6.0	360	190	2.7

See the nameplate for electrical and refrigeration specifications. The nameplate is located inside the cabinet.

We reserve the right to make changes in specifications and design without prior notice.

B. Wiring Diagrams

1a. Cabinet Fan Motor Control Module: 4A7178-01

PR46B: L50001G-M50052H, M50073H to N-6; (-D2): M-5 to N-6

PR60B: L50001G-M50007F, M50008H to N-6; (-D2)(-D4): M-5 to N-6

PR67B(-D2)(-D4): L-5 to N-6

PR93B(-D2)(-D4)(-D6): L-5 to N-6

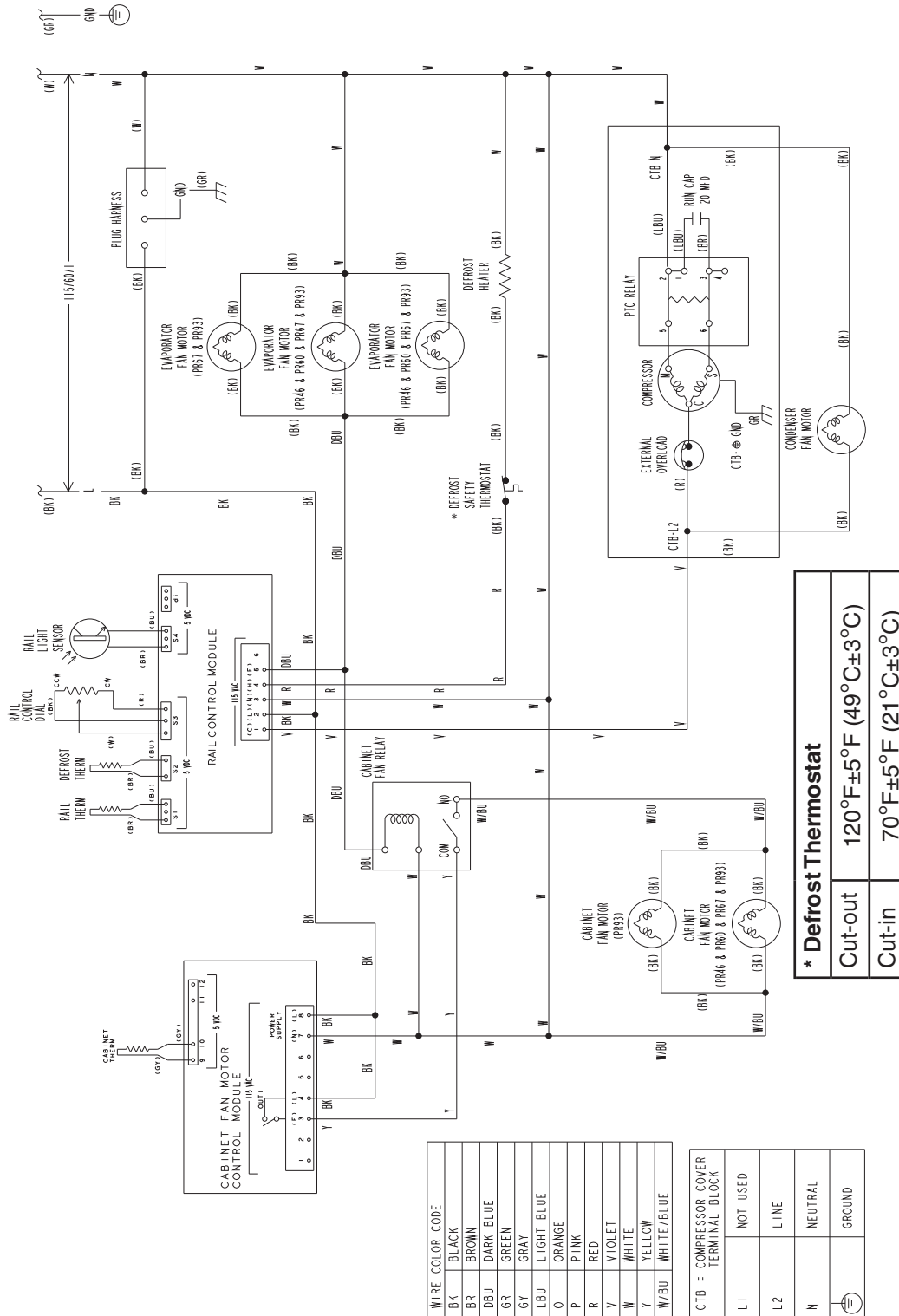

1b. Cabinet Fan Motor Control Module: 4A7178-01
PR46B(-D2): P-5 and Later
PR60B(-D2)(-D4): P-5 and Later
PR67B(-D2)(-D4): P-5 and Later
PR93B(-D2)(-D4)(-D6): P-5 and Later

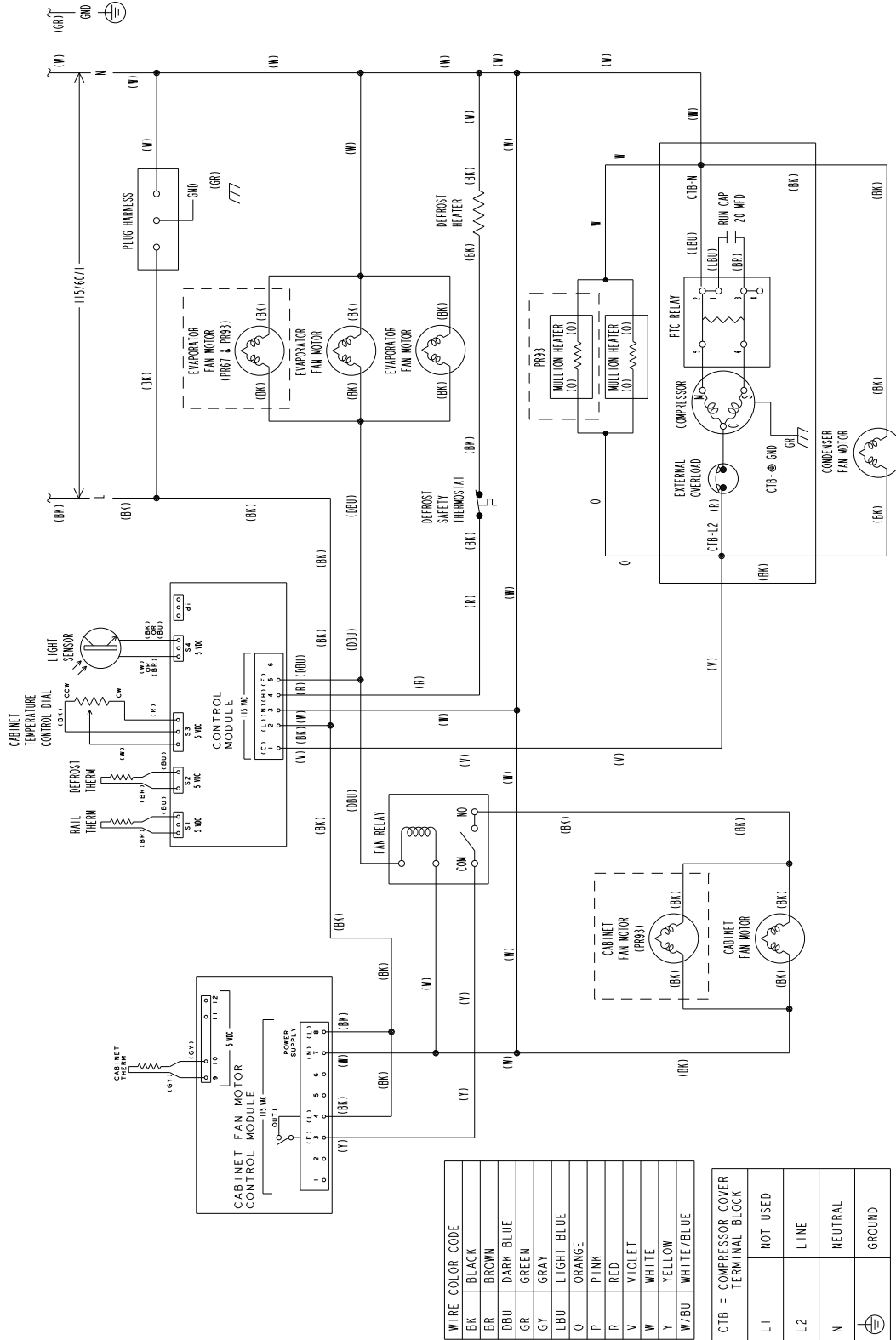

* Defrost Thermostat	
Cut-out	120°F±5°F (49°C±3°C)
Cut-in	70°F±5°F (21°C±3°C)

1c. Cabinet Fan Motor Control Module: 4A7053-01

PR46B: M50053H-M50072H

PR60B: M50008H-M50024

