

# MOTAK

## 2-section Prep Table

Model #: **MST-60-24-X**

### Product Details

- Eco-friendly R290 refrigerant
- Durable stainless steel top, and interior walls, floor, and ceiling
- Temperature range: 33 - 41°F
- Self-closing doors with 90° stay-open feature
- Adjustable, heavy-duty, coated shelves
- Factory-installed 4-inch swivel casters with brakes
- Electronic control system makes it easy to adjust temperature set point and defrost frequency
- Condenser coil is easy to access for cleaning and service

Not suitable for installation in non-commercial or residential applications.



### Warranty

2 years parts & labor and additional 3 years on compressor

### Certifications



### Specifications

Model	Doors	Shelves	Pans	Cabinet Dims (in)			HP	Voltage	Amp	NEMA Plug	Cord Length (ft)	Crated Weight (lbs)
				Width	Depth	Height						
MST-60-24-X	2	2	24 (1/6)	60.25"	34"	45.875"	1/4	115/60/1	7.0	5-15P	10 ft.	462 lbs.

### Plan View

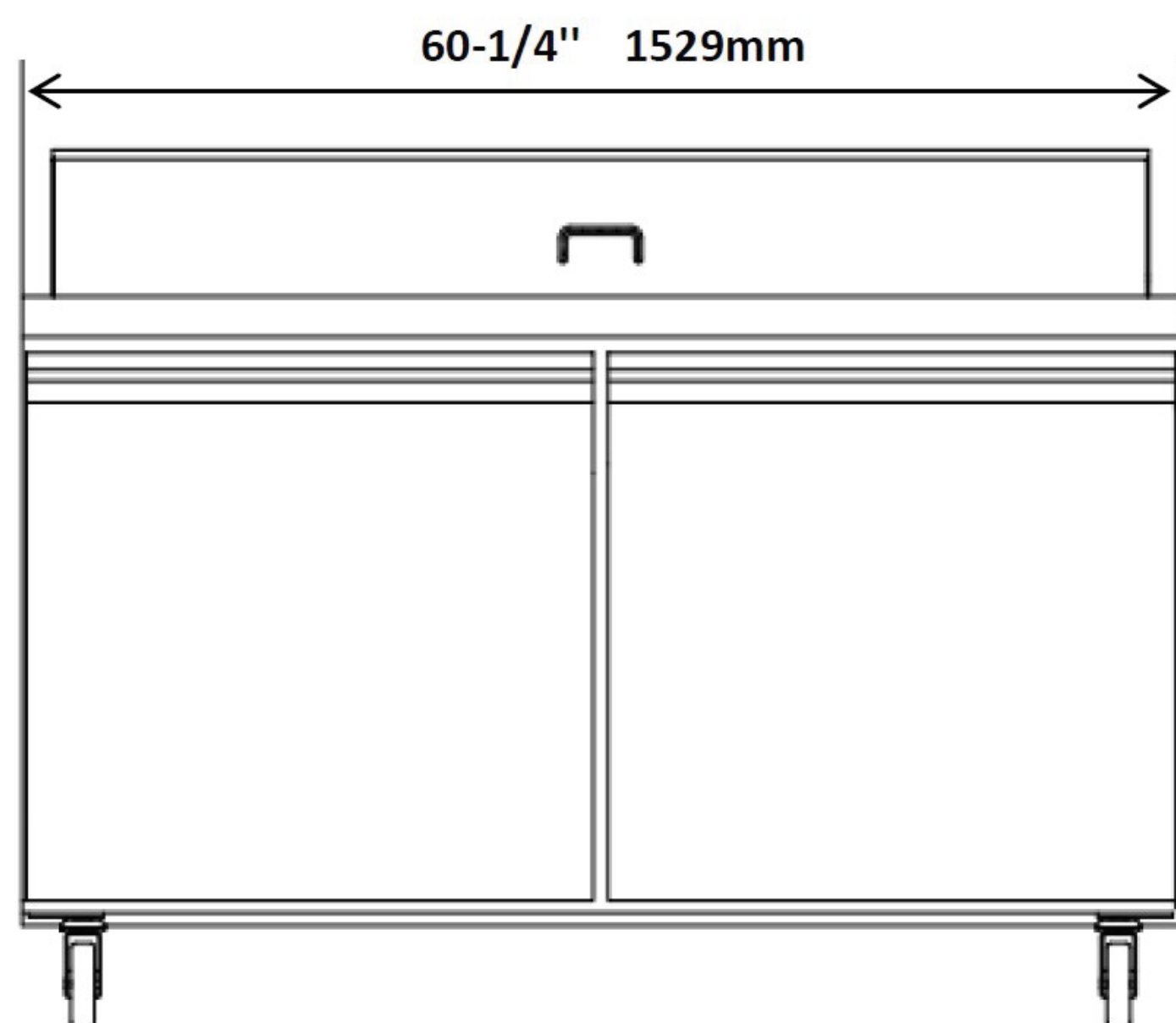

Front View

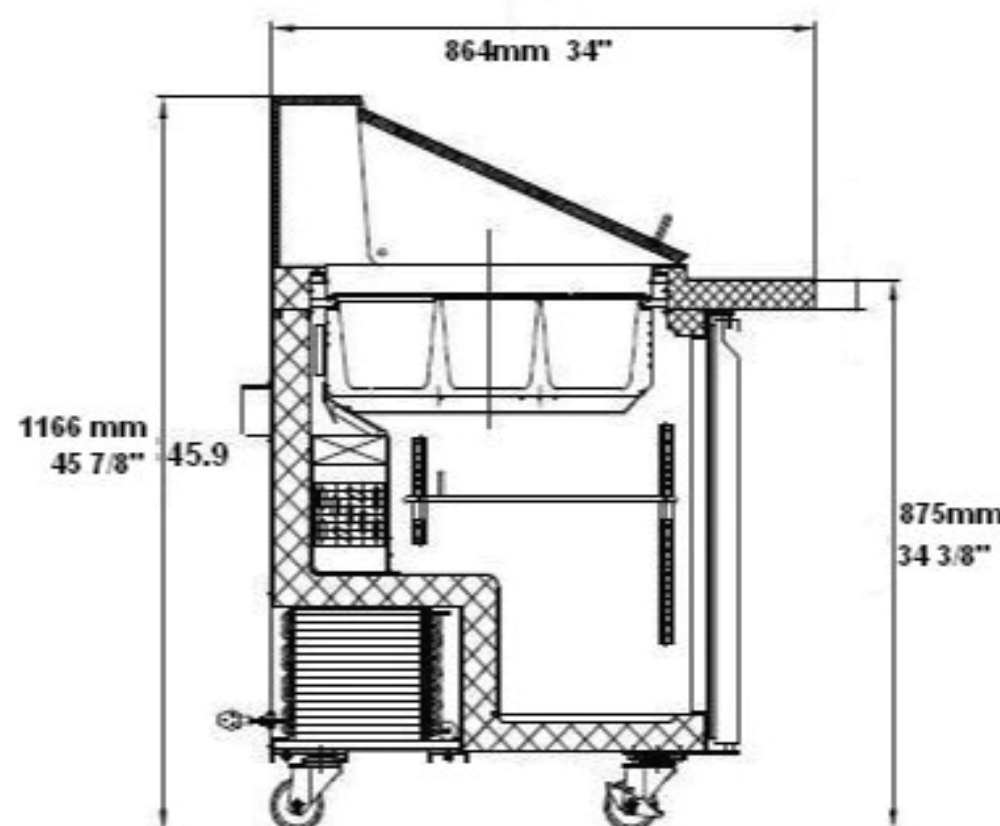

Side View

MOTAK reserves the right to make changes to the design or specifications without prior notice.