

MOTAK

Commercial Gas Range 2 Burners - 1 Griddle

Model #: **MR6-G24-C-S**

This commercial gas range has powerful 30,000-BTU cast iron burners. Each burner has a lift-off head, individual pilot light, heavy-duty 12" x 12" removable cast-iron grate, and individual instant light control knob. The range has a stainless steel front, 24.75" backriser and shelf, 6-inch adjustable stainless steel legs or casters, and a ¾" NPT gas connection.

The standard oven is powered with a 30,000-BTU burner and comes with two easy-to-remove oven racks. It includes a porcelain oven liner for easy cleaning and a compression spring door hinge system for durability. The oven thermostat adjusts from 200°F -500°F and is equipped with a flame-failure safety device.

Not suitable for installation in non-commercial or residential applications.



Warranty

1 year parts & labor

Product Details

Certifications

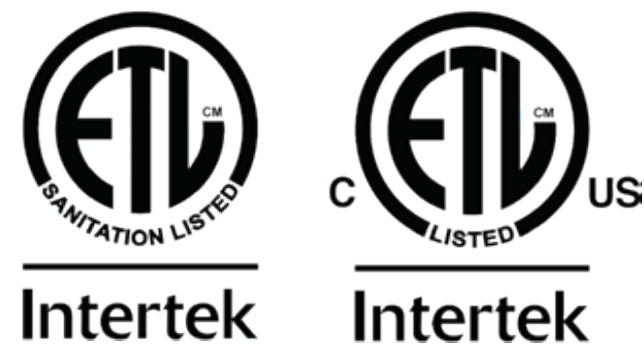

Intertek

Intertek

Top Burner

- 30,000-BTU/hr. cast-iron burners
- 12" x 12" cast iron top grates are removable for easy cleaning
- Each burner has an individual standing pilot light
- Push-in knob with efficient Hi-Low burner system
- Removable crumb tray

Griddle

- ¾"-thick griddle plate
- 4" welded griddle side shields
- Stainless steel "U" burner
- Heat every 6", control every 12"

Oven

- 30,000-BTU/hr. total output
- Flame-failure safety device
- Thermostatic control from 200-400°F
- Steel liner on door and sides with a porcelain oven liner
- Includes 2 removable and adjustable oven racks

Construction

- Stainless steel front, back riser, and shelf
- Spring-loaded door with cool-to-touch stainless steel oven door handle
- 6" stainless steel adjustable legs
- ¾" rear NPT gas connection

Commercial Gas Range 2 Burners - 1 Griddle

Plan View

- A pressure regulator is provided with this unit.
 - Natural Gas 4.0" W.C.
 - Propane Gas 10.0" W.C.
- Rear Gas Connection ¾" NPT

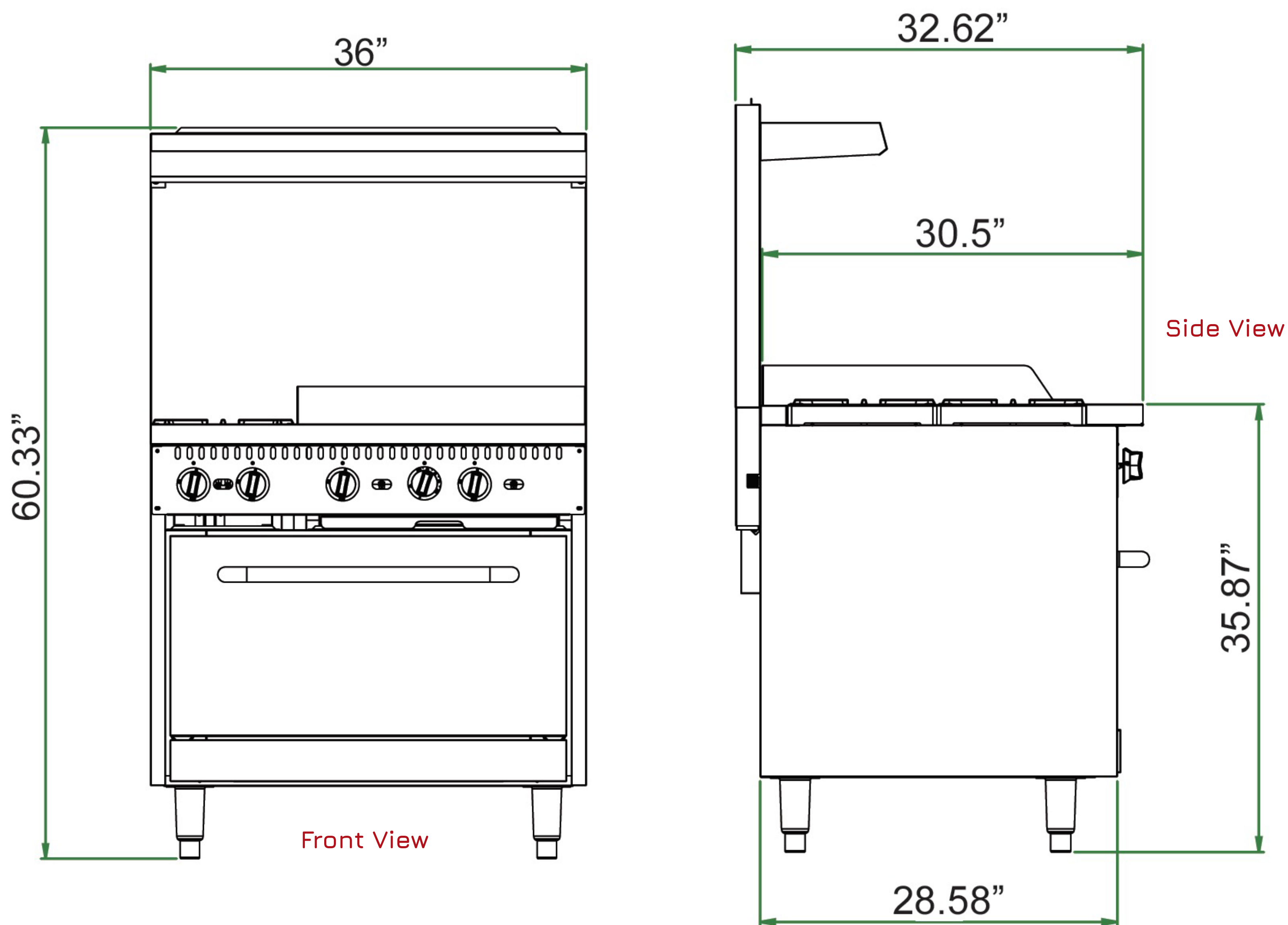

Specifications

Model	Burners	External Dimensions			Internal Oven Dimensions			BTU (Per Burner)	BTU (Per Oven)	BTU (Per Griddle Burner)	Total BTU	Crated Weight (lbs)
		Width	Depth	Height	Width	Depth	Height					
MR6-G24-C-S	2	36"	32.5"	60.5"	26.88"	25.8"	13.8"	30,000	30,000	20,000 × 2	130,000	507 lbs.

Not suitable for installation in non-commercial or residential applications.