

PLEXOR Ventless Submittal Information

PLEXOR Spec Sheet.....	1.1
UL Ventless Label.....	2.1
UL KNLZ Explained.....	3.1
Notice of Authorization to Apply to UL Mark (Safety) for Convection.....	4.1
Convection Emissions Test Results.....	5.1
Notice of Authorization to Apply to UL Mark (Safety) for Rapid Cook and Impingement.....	6.1
Rapid Cook and Impingement Test Results.....	7.1
Emissions by Product.....	8.1
Energy Usage Estimate.....	9.1
PLEXOR Surface Temperatures.....	10.1
TurboChef Installation Recommendations.....	11.1



PLEXOR



Features & Benefits

- Three (3) cooking technologies in one (1) appliance: rapid cook, impingement, convection, or any combination
- Operated by a single plug
- Single user interface makes training and operation simple
- Autoload/unload
- Ventless – integral recirculating catalytic converter for UL® (KNLZ) listed ventless operation
- Adaptive power management ensuring consistent results while power sharing
- Modular design: mix and match to fit your menu – change configuration with module field swaps
- Available in left-to-right, right-to-left, and front-to-back configurations
- Middleby Connect Wi-Fi ready for a connected kitchen
- Upload over 1,000 custom recipes via USB or WiFi
- Comes standard with cart and sealing gasket
- Includes plug and cord (6 ft. nominal)



Shown above with the convection, rapid cook, impingement modules installed. See page two for more information.

VENTILATION

- UL (KNLZ) listed for ventless operation.[†]
- EPA 202 test (8 hr):
 - Product: Pepperoni Pizzas
 - Convection Results: 0.20 mg/m³
 - Impingement Results: 1.33 mg/m³
 - Rapid Cook Results: 1.05 mg/m³
 - Ventless Requirement: <5.00 mg/m³
- Internal catalytic filtration to limit smoke, grease, and odor emissions.



SPECIFICATIONS

PHASE
3 Phase

VOLTAGE
208/240V

CURRENT
39A-49A

MAX CIRCUIT
50A

PLUG
NEMA 15-50P



This product conforms to the ventilation recommendations set forth by NFPA96 using EPA202 test method.

* Smart Voltage Sensor Technology does not compensate for lack of or over voltage situations. It is the responsibility of the owner to supply voltage to the unit according to the specifications on the back of this sheet.

[†] Ventless certification is for all food items except for foods classified as "fatty raw proteins." Such foods include bone-in, skin-on chicken, raw hamburger meat, raw bacon, raw sausage, steaks, etc. If cooking these types of foods, consult local HVAC codes and authorities to ensure compliance with ventilation requirements.

If you have questions regarding ventless certifications or local codes, please email ventless.help@turbochef.com TurboChef reserves the right to make substitutions of components or change specifications without prior notice.

©2021 TurboChef Technologies, LLC
DOC-1818 / Rev F / December 2021

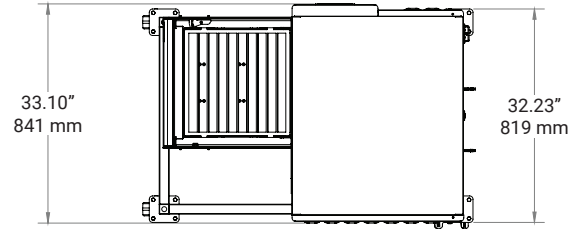
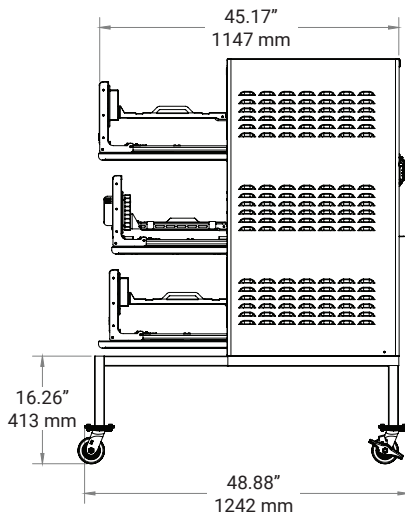
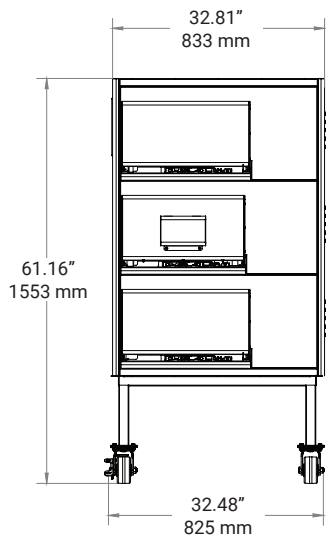

LEFT TO RIGHT/RIGHT TO LEFT

Height	61.16"	1553 mm
Width	48.88"	1242 mm
Depth	32.81"	833 mm

OVEN ONLY

Height	44.90"	1140 mm
Width	45.17"	1147 mm
Depth	33.10"	841 mm
Weight	610 lb.	277 kg

WALL CLEARANCE

Top	2"	51 mm
Sides	2"	51 mm

SHIPPING

Freight Class	175
Cube	48"x72"x58"
Shipping Weight	670 lb. (304 kg)
F.O.B.	Carrollton, TX

IMPINGEMENT – COOK CHAMBER

Height	3.4"	86 mm
Width	16.5"	419 mm
Depth	16.3"	414 mm
Volume	0.53 cu.ft.	15.0 liters

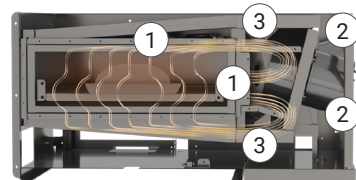

1. Heating Elements
2. Blower Motors
3. Catalytic Converters

RAPID COOK – COOK CHAMBER

Height	4.2"	107 mm
Width	14.0"	356 mm
Depth	14.0"	356 mm
Volume	0.48 cu.ft.	13.6 liters

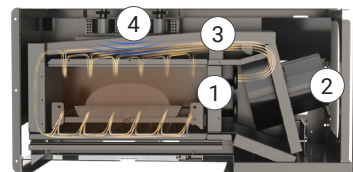

1. Heating Elements
2. Blower Motor
3. Catalytic Converter
4. Top-launched Microwave

CONVECTION – COOK CHAMBER

Height	3.7"	94 mm
Width	16.5"	419 mm
Depth	16.3"	414 mm
Volume	0.57 cu.ft.	16.1 liters

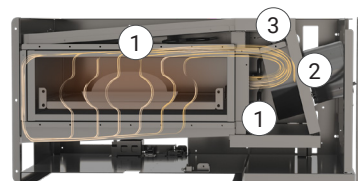

1. Heating Elements
2. Blower Motors
3. Catalytic Converters

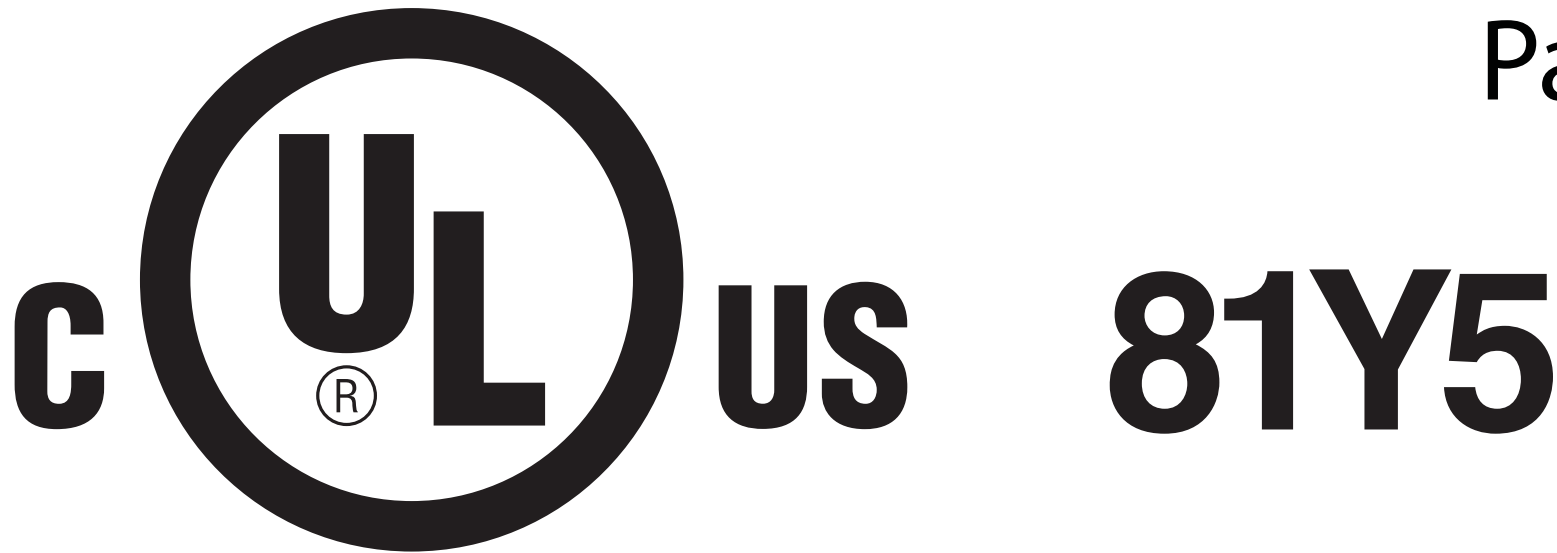

81Y5

LISTED

Commercial Cooking Appliance
with Integral Systems for Limiting
the Emissions of Grease-Laden Air

This Product Conforms to the Ventilation Recommendations
Set Forth by NFPA96 Using EPA202 Test Method

KNLZ.E151487 - Commercial Cooking Appliances with Integral Systems for Limiting the Emission of Grease-laden Air

Note: We are enhancing our systems and you may notice duplicate entries/missing/outdated data. During this interim period, please contact our Customer Service at <https://www.ul.com/about/locations>.

Commercial Cooking Appliances with Integral Systems for Limiting the Emission of Grease-laden Air

Turbochef Technologies Inc
2801 Trade Center Drive
Carrollton, TX 75007 United States

E151487

Trademark and/or Tradename: "BULLET"

Note: For additional marking information, refer to the [Guide Information Page](#).

Commercial Microwave/Convection Oven, Model(s): ECO, ECOST

Commercial microwave/convection ovens, Model(s): Encore 2, Encore*, i3*, i5*, NGC*, NGO*

Commercial ovens, Model(s): HHB, HHB2, HDD

Conveyor Ovens, Model(s): HCW2620, HHC1618, HHC2020, PS2020, PS2620

Conveyor Ovens, Model(s): 1618 may be prefixed by HCS, HCT, HCW or HHC

Conveyor Ovens, Model(s): 2020 may be prefixed by HCS, HCT, HCW or HHC

Conveyor Ovens, Model(s): 2620 may be prefixed by HCS, HCT, HCW or HHC

Triple Ovens, "Plexor", Model(s): AL-CCC followed by L or R., AL-CCI followed by L or R., AL-CCR followed by L or R., AL-CIC followed by L or R., AL-CII followed by L or R., AL-CIR followed by L or R., AL-CRC followed by L or R., AL-CRI followed by L or R., AL-CRR followed by L or R., AL-ICC followed by L or R., AL-ICI followed by L or R., AL-ICR followed by L or R., AL-IIC followed by L or R., AL-III followed by L or R., AL-IIR followed by L or R., AL-IRC followed by L or R., AL-IRI followed by L or R., AL-IRR followed by L or R., AL-RCC followed by L or R., AL-RCI followed by L or R., AL-RCR followed by L or R., AL-RIC followed by L or R., AL-RII followed by L or R., AL-RIR followed by L or R., AL-RRC followed by L or R., AL-RRI followed by L or R., AL-RRR followed by L or R.

* - Indicated complementary listed models.

Last Updated on 2021-11-08

The appearance of a company's name or product in this database does not in itself assure that products so identified have been manufactured under UL's Follow-Up Service. Only those products bearing the UL Mark should be considered to be Certified and covered under UL's Follow-Up Service. Always look for the Mark on the product.

UL permits the reproduction of the material contained in the Online Certification Directory subject to the following conditions: 1. The Guide Information, Assemblies, Constructions, Designs, Systems, and/or Certifications (files) must be presented in their entirety and in a non-misleading manner, without any manipulation of the data (or drawings). 2. The statement "Reprinted from the Online Certifications Directory with permission from UL" must appear adjacent to the extracted material. In addition, the reprinted material must include a copyright notice in the following format: "© 2021 UL LLC"



November 22, 2021

Mr. David Castillo
Turbochef Technologies Inc.
2801 Trade Center Drive
Carrollton, TX, 75007
US

E-mail: david.castillo@turbochef.com

Reference: Project : 4789882004
Product: EPA 202 TEST METHOD: "PLEXOR 16-INCH" SERIES CONVECTION OVEN
COOKING THE BELOW FOOD PRODUCT AS MEDIA.

Dear Mr. Castillo,

An evaluation of grease-laden vapors produced by the "Plexor 16-inch" convection oven was conducted under project 4789882004.

The scope of this evaluation was to determine the total grease emissions from cooking 12-inch pepperoni pizzas (Tombstone, having 18 slices of pepperoni per pizza). Testing was conducted in accordance with EPA Method 202 test guidelines to determine ultimate results. Results are used to determine compliance with Section 59 of UL710B, the Standard for Recirculating Systems, formerly Section 14 of UL 197, Eighth Edition, Supplement SB, and paragraph 4.1.1.2 of NFPA 96, the Standard for Ventilation Control and Fire Protection of Commercial Cooking Operations. The tests were conducted at the UL facility in Northbrook, IL between July 21, 2021 and July 29, 2021. This letter will report the results of the EPA202 test. See attached Appendix A for results of testing the Plexor 16-in. convection oven.

The test was conducted using the following samples with the following results:

Plexor 16-inch convection module, mounted as the top oven module in a three-module enclosure as intended in production. The test media, food load and oven programming as shown in Appendix A were taken from UL 710B, section 59. The results are considered to comply with UL710B, Section 59, formerly Section 14 of UL 197, Eighth Edition, Supplement SB, and NFPA96, paragraph 4.1.1.2 when tested with the specified food load and maximum cook times since the total amount of grease-laden effluents collected was 0.20 mg/m³, which is less than 5 mg/m³ limit. Further, this test is considered representative of up to three stacked 16-inch convection modules, since the measured grease-laden effluents collected were less than 1/3 of the limit. No evaluation was conducted in regards to fire protection.

Please note that pizza was used based upon your assurance that the oven would be marked to indicate that it is for reheating of cooked food only, or not for cooking of foods producing grease-laden vapors, or a similar marking. The exact text of the marking has yet to be finalized.

UL LLC did not select the samples, determine whether the samples were representative of production samples or witness the production of the test samples, nor were we provided with information relative to the formulation or identification of component materials used in the test samples. The test results apply only to the actual samples tested.



The issuance of this report in no way implies Listing, Classification or Recognition by UL LLC and does not authorize the use of UL Listing, Classification or Recognition Marks or any other reference to UL LLC on the product or system. UL LLC authorizes the above named company to reproduce this Report provided it is reproduced in its entirety. The name, Brand or Marks of UL LLC cannot be used in any packaging, advertising, promotion or marketing relating to the data in this Report, without UL's prior written permission.

UL, its employees and agents shall not be responsible to anyone for the use or nonuse of the information contained in this Report, and shall not incur any obligation or liability for damages, including consequential damages, arising out of or in connection with the use of, or inability to use, the information contained in this Report.

All information generated will be retained for future use.

Thank you for the opportunity to provide your company with these services. Please do not hesitate to contact us if you should have any questions or comments.

Regards,

A handwritten signature in black ink that reads "Smit Thakkar".

Smit Thakkar
Associate Project Engineer
E-mail: Smit.Thakkar@ul.com

Reviewed by:

A handwritten signature in black ink that reads "Fred Zaplatosch".

Fred Zaplatosch
Senior Staff Engineer
E-mail: Fred.Zaplatosch@ul.com

AUDIT INFORMATION:				
Description of Tests	Per Standard No.	UL 197	Edition/Revision Date	10 th 2020-07-10
		CSA C22.2 No. 109-17		3 rd 2021-03
		UL 710B		2 nd 2019-02-01
<input checked="" type="checkbox"/> Tests Conducted by ¹ KRZYSZTOF SROKA				
<input checked="" type="checkbox"/> UL Staff supervising UL Staff in training Leo Carrillo				

TESTS TO BE CONDUCTED:				
Test No.	Done ³	Test Name	<input type="checkbox"/> Comments/Parameters <input type="checkbox"/> Tests Conducted by ² <input type="checkbox"/> Link to separate data files ⁴	
1	2021-07-21	POWER INPUT TEST (SINGLE PHASE RATED OVER 120V): RATING (CSA 22.2 109-17):	Project: 4789533958 Project: 4789882004	
2	2021-07-20	CAPTURE TEST (CONVECTION OVEN):	Project: 4789533958 Project: 4789882004	
3	2021-07-29	EMISSION TEST (CONVECTION OVEN):	Project: 4789533958 Project: 4789882004	

Instructions -

- 1 - When all tests are conducted by one person, name can be inserted here instead of including name on each page containing data.
- 2 - When test conducted by more than one person, name of person conducting the test can be inserted next to the test name instead of including name on each page containing data. Test dates may be recorded here instead of entering test dates on the individual datasheet pages.
- 3 - Use of this field is optional and may be employed differently. If used to include a date instead of entering the testing date on the individual datasheet pages, the date shall be the date the test was conducted.
- 4 - Link to separate data files for a test can be inserted here. The link must be to a server that is accessible to UL staff, that provides for backup, required retention periods and a path, including file name, that does not change and result in a broken link. Not applicable to DAP.

Special Instructions -

Unless specified otherwise in the individual Methods, the tests shall be conducted under the following ambient conditions. Confirmation of these conditions shall be recorded at the time the test is conducted.

Ambient Temperature, C 10-40 Relative Humidity, % ± Barometric Pressure, mBar ±

No general environmental conditions are specified in the Standard(s) or have been identified that could affect the test results or measurements.

RISK ANALYSIS RELATED TO TESTING PERFORMANCE:

The following types of risks have been identified. Take necessary precautions. This list is not all inclusive.

<input checked="" type="checkbox"/> Electric shock	<input type="checkbox"/> Radiation
<input checked="" type="checkbox"/> Energy related hazards	<input type="checkbox"/> Chemical hazards
<input checked="" type="checkbox"/> Fire	<input type="checkbox"/> Noise
<input checked="" type="checkbox"/> Heat related hazards	<input type="checkbox"/> Vibration
<input checked="" type="checkbox"/> Mechanical	<input type="checkbox"/> Other (Specify) __

GENERAL TEST CONSIDERATIONS - ALL TESTS:

[Power Supply Connections]

Unless otherwise specified in the individual test methods, the appliance was connected to a [240] volt source of supply at [60] Hz.

This supply connection was based on

- The marked voltage rating
- The highest voltage of the applicable range of voltages

Parts removable without the use of tools were tested in the worst case condition (i.e., with or without the removable part). The removable parts were _____.

TEST LOCATION: (To be completed by Staff Conducting the Testing)					
<input checked="" type="checkbox"/> UL or Affiliate	<input type="checkbox"/> WTDP	<input type="checkbox"/> CTDP	<input type="checkbox"/> TPTDP	<input type="checkbox"/> TCP	<input type="checkbox"/> PPP
Company Name: UL LLC					
Address: 333 PFINGSTEN RD, NORTHBROOK IL 60062					

TEST EQUIPMENT INFORMATION

UL test equipment information is recorded on Meter Use.

TEST SAMPLE IDENTIFICATION:

The table below is provided to establish correlation of sample numbers to specific product related information. Refer to this table when a test identifies a test sample by "Sample No." only.

Sample Card No.	Date Received	<input type="checkbox"/> Test No.+	Sample No.	Manufacturer, Product Identification and Ratings
3806877	2021-05-03	All	1	Plexor series oven assembly, rated 208 V, 40 A total. Assembly consists of one 16-inch convection module, one 16-inch impingement module, and one 14-inch rapid cook module (fits in 16-inch size frame). The convection module was on top.
3962799	2021-06-14	All	(now part of sample 1)	Convection sleeve and door for Plexor. Installed in sample 3806877.
3994089	2021-06-15	All	(now part of sample 1)	RAPID COOK MODULE FOR HIGH VOLTAGE TEST & BACK PANEL (installed into sample 3806877)
				NOTE: Testing oven at 240 V, without "pulsing" to limit power input to 208 V levels, as a worst-case condition.

+ - If Test Number is used, the Test Number or Numbers the sample was used in must be identified on the data sheet pages or on the Data Sheet Package cover page.

Sampling Procedure -

This document contains data or information using color and if printed, should be printed in color to retain legibility and the information represented by the color.

POWER INPUT TEST (SINGLE PHASE RATED OVER 120V):
RATING (CSA 22.2 109-17):

UL 197 Sec. 47
(6.2)

METHOD

[x] The supply voltage was adjusted to 240 V, 60 Hz.

The power input was measured with the appliance at the intended operating temperature under full-load conditions.

(c-UL) To determine the proper test voltage for the Temperature (Normal) and Temperature (Abnormal) tests, the supply voltage was adjusted to the increased test voltage as noted below. Following the test at increased test voltage, the supply voltage was adjusted to the value necessary to cause the appliance to draw the increased test current, calculated as specified below.

Increased Test Voltage (V_t): 216V for appliances rated 208V.
250V for appliances rated between 220V-250V.

Increased Test Current (I_t): $I_r(V_t/V_r) = \text{see below}$
Increased Test Power (W_t): $W_r(V_t/V_r)^2 = \text{see below}$

Where V_r , I_r , and W_r , are the rated voltage, current, and power of the appliance, respectively. Note: when the appliance is rated for a range of voltages, the mean of the range is to be used as V_r .

PARAMETERS

Appliance Ratings: Volts: 240; Current: 30 A

Note: The overall assembly is 3-phase and must be connected to 3-phase for the controls and cooling fans to work correctly. However, we are only running one oven, the convection oven, which is connected single-phase from L2-L3 (some of the fans and controls are connected L1-L2). Also, this unit is rated 208 V, but we are testing at 240V to represent a future 240 V version of the oven.

RESULTS

CONVECTION MODULE:

	Specified	Measured

Operating Conditions	Volts	Amps			Power, W	Volts			Amps			Power, (W) (kW)
		L1	L2	L3		L1-L2	L2-L3	L1-L3	L1	L2	L3	
Convection Oven, full power operation, rated voltage	240	---	---	---	---	244	240	241	0.5	30.0	30.4	7293.3
Convection Oven, full power operation, rated current	---		30	30	---	244	240	241	0.5	30.0	30.4	7293.3
C-UL Operating Conditions												
Convection Oven, full power operation, increased test voltage	250	---	---	---	---	254	250	251	0.5	31.1	31.6	7886.8
Convection Oven, full power operation, increased test current	---		31	31	---	254	249	251	0.5	31.0	31.5	7835.5

The input current [was] [~~was not~~] between 90% and 105% of the rated input current when the appliance was energized at rated voltage.

METHOD

The model Plexor series oven cooking appliance was placed under a hood operating at 500 CFM. The convection oven was placed in the topmost position. Food product as specified below was then used for testing, see Emission Testing for specific details. The cooking area is to be observed for the presence of visible smoke and grease-laden air, and the hood assembly shall completely capture all of the emission as determined by observation.

COOKING PRODUCT

- Oven - 12 in. pepperoni pizza
 - Tombstone, with 18 pepperonis per pizza
 - Kirkland, with ___ pepperonis per pizza

For testing ovens, as an alternate, when pizza does not produce visible cooking smoke and grease laden air, one sheet pan (nominal pan size 18 by 26 inches) filled with 1 lb of pork bacon and coated with one cup of sugar distributed evenly is permitted to be used. The pan shall be placed at the lowest location (rack) of the oven, and the oven run at the maximum temperature for 10 minutes.

COOKING METHOD

[Other]

12 in. Tombstone pepperoni pizza, each cooked for 4 minutes with 0 seconds between loads for 8 hours (total of 109 pizzas cooked). Oven was set to maintain 525°F with ~~top and bottom~~ blower set to 100%.

RESULTS

There ~~was~~ [was not] the presence of visible smoke and grease-laden air from the appliance during testing.

The sample [did] ~~[did not]~~ capture all of the emissions from the cooking appliance.

METHOD

TEST FOR EVOLUTION OF SMOKE OR GREASE-LADEN AIR (525°F):

The model Plexor series oven cooking appliance was placed under a hood operating at 500 CFM, with the Convection module placed in the topmost position. The oven was tested with only the Convection Module operating, using a method derived from EPA Method 202.

Note: With the consent of all concerned, a single oven module was tested. If the emission is less than 1/3 of the limit, the modules will be allowed to be stacked with up to three modules in a single enclosure.

UL LLC provided the food load for the test.

A 12 in. by 6 in. rectangular, 108 in. tall sheet metal stack was constructed on top of the hood. A sampling port was located approximately 80 in. downstream from the hood exhaust, at which point it was determined there was laminar flow. The sampler was assembled and an out of stack filter was used. A pre-leak check was conducted and determined to be < 0.02 ft/min. Sampling was determined to be done at 8 traverse points.

The oven was operated normally by cooking the following foods:

[Other]

[x] Oven - 12 in. pepperoni pizza

[x] Tombstone, with 18 pepperonis per pizza

[] Kirkland, with ___ pepperonis per pizza

12 in. Tombstone pepperoni pizza, each cooked for 4 minutes with 0 seconds between loads for 8 hours (total of 109 pizzas cooked). Oven was set to maintain 525°F with ~~top and bottom~~ blower set to 100%.

During the cooking operation, it was noted whether or not visible effluents evolved from the air exhaust of the hood. Gauge, meter and temperature readings were taken and recorded every 10 min. After cooking, the condition of the duct was noted and a post-leak check was conducted and determined to be < 0.02 ft³/min.

After being allowed to cool, the sampling equipment was disassembled. The glass-filter is to be removed using a pair of forceps and placed in a clean petri dish. The dish is to be sealed and labeled "SAMPLE 1".

A sample of the acetone of the same volume that will be used to rinse-out the nozzle and probe is to be placed into a clean sample bottle, sealed, and labeled "SAMPLE 2". The level of the liquid in the sample bottle is to be recorded.

The inside of the nozzle and probe is to be rinsed with acetone taking care to collect all the rinse material in a clean sample bottle. The sample bottle is to be sealed, labeled "SAMPLE 3", and the level of the liquid in the bottle is to be recorded.

The liquid in the first three impingers is to be measured and the total volume is to be recorded which will be compared to the original volume. The liquid is to be quantitatively transferred to a clean sample bottle. Each impinger and the connecting glassware including the probe extension are to be rinsed twice with water. The rinse water is to be collected and added to the same sample bottle. The sample bottle is to be sealed, labeled "SAMPLE 4" and the level of the liquid in the bottle is to be recorded.

This rinse process is to be repeated with two rinses of methylene chloride (MeCl_2). The rinses are to be recovered in a clean sample bottle. The sample bottle is to be sealed, labeled "SAMPLE 5" and the level of the liquid in the bottle is to be recorded.

A volume of water approximately equivalent to the volume of water used to rinse and a volume of MeCl_2 approximately equivalent to the volume of MeCl_2 used to rinse is to be placed in two clean sample bottles. The sample bottles are to be sealed, labeled "SAMPLE 6" and "SAMPLE 7" respectively, and the level of the liquid in the bottles is to be recorded.

The weight of the fourth impinger containing the silica gel is to be recorded and then the silica gel can be discarded.

The analysis phase was done in accordance with EPA Method 202, using the out of stack filter.

RESULTS

The results [are] [~~are not~~] considered acceptable because there [~~was~~] [was no] visible smoke emitted from the exhaust of the hood during the normal cooking operation. There [~~was~~] [was no] noticeable amounts of smoke accumulated in the test room after 8 hours of continuous cooking.

The total amount of grease-laden effluents collected by the sampling equipment was found to be 0.20 mg/m^3 , which is [less] [~~more~~] than 5 mg/m^3 . +

The total grease emissions (per clause 78.2 of 710B) in pounds per hour per linear food of hood was $0.000092 \text{ lb/hr/ft}$.

Note: Stack avg humidity and temperature;

Stack temperature; 81.2°F

HUMIDITY INSIDE STACK; 38.7%

Note: Additional spreadsheet is to be used when conducting the Emission Test. This spreadsheet (EPA 202) can be found in the Lab Equipment Management System (LEM) under global ID 58255.

+ Note: With the consent of all concerned, a single oven module was tested. If the emission is less than 1/3 of the limit, the ovens will be allowed to be stacked with up to three oven modules in a single enclosure.

CONDENSIBLE MATTER
(Lab Analysis)

Sample Bottle No.	Description	Volume, ml	Final Wt, mg
2	Acetone (Blank)	100.0	0.2
3	Acetone (Wash)	100.0	0.2
4&5	Solvent Phase (Wash)	210.0	1.6
4&5	Water Phase (Wash)	310.0+320.0=630.0	2.4
6&7	Solvent Phase (Blank)	490.0	0.4
6&7	Water Phase (Blank)	490.0	2.1

Filter paper weight before test- 605.9 mg

Filter paper weight after test- 606.0 mg

Analysis

1. The liquid level of all the sample bottles is to be measured.
2. The filter from sample ONE is to be removed and dried to constant weight by means of a desiccator or an oven. The weight of the filter is to be recorded.
3. The volume of sample TWO is to be determined. The liquid is then to be transferred to a beaker and evaporated to dryness. The volume of the liquid and the final weight of the condensable matter are to be recorded.
4. The volume of sample THREE is to be determined. The liquid is then to be transferred to a beaker and evaporated to dryness. The volume of the liquid and the final weight of the condensable matter are to be recorded.
5. The volumes of sample FOUR and FIVE are to be measured.
6. Samples FOUR and FIVE are to be combined. The solvent phase is to be mixed, separated, and then repeated with two MeCl_2 washes.
7. The solvent extracts obtained from the procedure in 6 are to be placed in a beaker and evaporated to a constant weight. The final weight is to be recorded.
8. The water phase is to be placed in a beaker and evaporated to dryness. The final weight is to be recorded.
9. The volumes of samples SIX and SEVEN are to be determined. Sample bottles SIX and SEVEN are to be analyzed according to procedures 8 and 7 respectively.

END OF DATASHEET PACKAGE. THIS PAGE INTENTIONALLY LEFT BLANK

November 22, 2021



Mr. David Castillo
Turbochef Technologies Inc.
2801 Trade Center Drive
Carrollton, TX, 75007

E-mail: david.castillo@turbochef.com

Reference: Project : 4789533958

Product: EPA 202 TEST METHOD: "PLEXOR 16-INCH" SERIES IMPINGEMENT AND
RAPID-COOK OVENS COOKING THE BELOW FOOD PRODUCT AS MEDIA.

Dear Mr. Castillo,

An evaluation of grease-laden vapors produced by the "Plexor 16-inch" impingement and rapid-cook ovens was conducted under project 4789533958.

The scope of this evaluation was to determine the total grease emissions from cooking 12-inch pepperoni pizzas (Tombstone, having 18 slices of pepperoni per pizza). Testing was conducted in accordance with EPA Method 202 test guidelines to determine ultimate results. Results are used to determine compliance with Section 59 of UL710B, the Standard for Recirculating Systems, formerly Section 14 of UL 197, Eighth Edition, Supplement SB, and paragraph 4.1.1.2 of NFPA 96, the Standard for Ventilation Control and Fire Protection of Commercial Cooking Operations. The tests were conducted at the UL facility in Northbrook, IL between January 20, 2021 and January 29, 2021. This letter will report the results of the EPA202 test.

The test was conducted using the following samples with the following results:

1. Plexor 16-inch impingement module, mounted as the top oven module in a three-module enclosure as intended in production. The test media, food load and oven programming as shown in Appendix A were taken from UL 710B, section 59. The results are considered to comply with UL710B, Section 59, formerly Section 14 of UL 197, Eighth Edition, Supplement SB, and NFPA96, paragraph 4.1.1.2 when tested with the specified food load and maximum cook times since the total amount of grease-laden effluents collected was 1.33 mg/m³, which is less than 5 mg/m³ limit. Further, this test is considered representative of up to three stacked 14-inch impingement modules, since the measured grease-laden effluents collected were less than 1/3 of the limit. No evaluation was conducted in regards to fire protection.
2. Plexor 14-inch rapid-cook module (the size that fits in the Plexor 16-inch series enclosure), mounded as the top oven module in a three-module enclosure as intended in production. The test media, food load and oven programming as shown in Appendix A were taken from UL 710B, section 59. The results are considered to comply with UL710B, Section 59, formerly Section 14 of UL 197, Eighth Edition, Supplement SB, and NFPA96, paragraph 4.1.1.2 when tested with the specified food load and maximum cook times since the total amount of grease-laden effluents collected was 1.05 mg/m³, which is less than 5 mg/m³ limit. Further, this test is considered representative of up to three stacked 14-inch impingement modules, since the measured grease-laden effluents collected were less than 1/3 of the limit. No evaluation was conducted in regards to fire protection.



UL LLC did not select the samples, determine whether the samples were representative of production samples or witness the production of the test samples, nor were we provided with information relative to the formulation or identification of component materials used in the test samples. The test results apply only to the actual samples tested.

The issuance of this report in no way implies Listing, Classification or Recognition by UL LLC and does not authorize the use of UL Listing, Classification or Recognition Marks or any other reference to UL LLC on the product or system. UL LLC authorizes the above named company to reproduce this Report provided it is reproduced in its entirety. The name, Brand or Marks of UL LLC cannot be used in any packaging, advertising, promotion or marketing relating to the data in this Report, without UL's prior written permission.

UL, its employees and agents shall not be responsible to anyone for the use or nonuse of the information contained in this Report, and shall not incur any obligation or liability for damages, including consequential damages, arising out of or in connection with the use of, or inability to use, the information contained in this Report.

All information generated will be retained for future use.

Thank you for the opportunity to provide your company with these services. Please do not hesitate to contact us if you should have any questions or comments.

Regards,

Reviewed by:

A handwritten signature in black ink that reads "Smit Thakkar".

A handwritten signature in black ink that reads "Fred Zaplatosch".

Smit Thakkar
Associate Project Engineer
E-mail: Smit.Thakkar@ul.com

Fred Zaplatosch
Senior Staff Engineer
E-mail: Fred.Zaplatosch@ul.com

AUDIT INFORMATION:				
Description of Tests	Per Standard No.	UL 197	Edition/Revision Date	10 th 2020-07-10
		CSA C22.2 No. 109-17		3 rd 2017-05
		UL 710B		2 nd 2/1/2019
<input checked="" type="checkbox"/> Tests Conducted by ¹ KRZYSZTOF SROKA				
<input checked="" type="checkbox"/> UL Staff supervising UL Staff in training Leo Carrillo				

TESTS TO BE CONDUCTED:				
Test No.	Done ³	Test Name	<input type="checkbox"/> Comments/Parameters <input type="checkbox"/> Tests Conducted by ² <input type="checkbox"/> Link to separate data files ⁴	
1	2021-01-28	POWER INPUT TEST (SINGLE PHASE RATED OVER 120V): RATING (CSA 22.2 109-17):		
2	2021-01-20	CAPTURE TEST (IMPINGEMENT):		
3	2021-01-26	CAPTURE TEST (RAPID-COOK (MICROWAVE/CONVECTION)):		
4	2021-01-12	CAPTURE TEST (CONVECTION OVEN):		
5	2021-01-29	EMISSION TEST (IMPINGEMENT):		
6	2021-01-29	EMISSION TEST (RAPID-COOK (MICROWAVE/CONVECTION)):		
7	2021-01-20	EMISSION TEST (CONVECTION OVEN):		

Instructions -

1 - When all tests are conducted by one person, name can be inserted here instead of including name on each page containing data.

2 - When test conducted by more than one person, name of person conducting the test can be inserted next to the test name instead of including name on each page containing data. Test dates may be recorded here instead of entering test dates on the individual datasheet pages.

3 - Use of this field is optional and may be employed differently. If used to include a date instead of entering the testing date on the individual datasheet pages, the date shall be the date the test was conducted.

4 - Link to separate data files for a test can be inserted here. The link must be to a server that is accessible to UL staff, that provides for backup, required retention periods and a path, including file name, that does not change and result in a broken link. Not applicable to DAP.

Special Instructions -

[] Unless specified otherwise in the individual Methods, the tests shall be conducted under the following ambient conditions. Confirmation of these conditions shall be recorded at the time the test is conducted.

Ambient Temperature, C _____ ± _____ Relative Humidity, % _____ ± _____ Barometric Pressure, mBar _____ ± _____

[X] No general environmental conditions are specified in the Standard(s) or have been identified that could affect the test results or measurements.

RISK ANALYSIS RELATED TO TESTING PERFORMANCE:

The following types of risks have been identified. Take necessary precautions. This list is not all inclusive.

<input checked="" type="checkbox"/> Electric shock	<input type="checkbox"/> Radiation
<input checked="" type="checkbox"/> Energy related hazards	<input type="checkbox"/> Chemical hazards
<input checked="" type="checkbox"/> Fire	<input type="checkbox"/> Noise
<input checked="" type="checkbox"/> Heat related hazards	<input type="checkbox"/> Vibration
<input checked="" type="checkbox"/> Mechanical	<input type="checkbox"/> Other (Specify) __

GENERAL TEST CONSIDERATIONS - ALL TESTS:

[Power Supply Connections]

Unless otherwise specified in the individual test methods, the appliance was connected to a [240] volt source of supply at [60] Hz.

This supply connection was based on

[x] The marked voltage rating

[] The highest voltage of the applicable range of voltages

[] Parts removable without the use of tools were tested in the worst case condition (i.e., with or without the removable part). The removable parts were _____.

TEST LOCATION: (To be completed by Staff Conducting the Testing)					
<input checked="" type="checkbox"/> UL or Affiliate	<input type="checkbox"/> WTDP	<input type="checkbox"/> CTDP	<input type="checkbox"/> TPTDP	<input type="checkbox"/> TCP	<input type="checkbox"/> PPP
Company Name: UL LLC					
Address: 333 PFINGSTEN RD, NORTHBROOK IL 60062					

TEST EQUIPMENT INFORMATION

UL test equipment information is recorded on Meter Use.

TEST SAMPLE IDENTIFICATION:

The table below is provided to establish correlation of sample numbers to specific product related information. Refer to this table when a test identifies a test sample by "Sample No." only.

Sample Card No.	Date Received	<input type="checkbox"/> Test No.+	Sample No.	Manufacturer, Product Identification and Ratings
3462131	2020-11-20	All	1	Plexor series ovens, rated 240 V, 40.1 A total. See below for individual oven ratings.
				Impingement Oven: 240 V, 40.1 A
				Rapid Cook Oven: 240 V, 22.6 A
				Convection Oven: 240 V, 33.0 A

+ - If Test Number is used, the Test Number or Numbers the sample was used in must be identified on the data sheet pages or on the Data Sheet Package cover page.

Sampling Procedure -

This document contains data or information using color and if printed, should be printed in color to retain legibility and the information represented by the color.

POWER INPUT TEST (SINGLE PHASE RATED OVER 120V):
 RATING (CSA 22.2 109-17):

UL 197 Sec. 47
 (6.2)

METHOD

[x] The supply voltage was adjusted to voltage and frequency as noted in "General Test Considerations", [240 V], [60 Hz].

[] The supply voltage was adjusted to the [rated voltage] [mean of the rated voltage range] at rated frequency, [__ V], [__ Hz].

The power input was measured with the appliance at the intended operating temperature under full-load conditions.

[x] (c-UL) To determine the proper test voltage for the Temperature (Normal) and Temperature (Abnormal) tests, the supply voltage was adjusted to the increased test voltage as noted below. Following the test at increased test voltage, the supply voltage was adjusted to the value necessary to cause the appliance to draw the increased test [current] [and] [power], calculated as specified below.

Increased Test Voltage (V_t): 216V for appliances rated 208V.
 250V for appliances rated between 220V-250V.

Increased Test Current (I_t): $I_r(V_t/V_r) =$ see below

Increased Test Power (W_t): $W_r(V_t/V_r)^2 =$ see below

Where V_r , I_r , and W_r , are the rated voltage, current, and power of the appliance, respectively. Note: when the appliance is rated for a range of voltages, the mean of the range is to be used as V_r .

PARAMETERS

Appliance Ratings:

Volts: 240 ; Current: 25 A; Power: _____ (W) (kW)

RESULTS

IMPINGEMENT OVEN:

Operating Conditions	Specified				Measured			
	Volts, L1-L2	Amps		Power, W	Volts, L1-L2	Amps		Power, W
		L1	L2			L1	L2	
Impingement Oven, full power operation, rated voltage	240	---	---	---	240	36.6	36.6	8787
Impingement Oven, full power operation, rated current	---	40.1	40.1	---	267.9	40.1	40.1	10721
Impingement Oven, full power operation, rated power	---	---	---					
c-UL Test Conditions								
Impingement Oven, full power operation, increased test voltage	250	---	---	---	250	37.5	37.5	9365
Impingement Oven, full power operation, increased test current	---	41.8	41.8	---		*	*	
Impingement Oven, full power operation, increased test power	---	---	---					

*Note: Variable control module must be installed in unit because it will not allow me to achieve the high amp of 41.8. instead it fluctuates up to 40.1 and will not let me go over that. KRZYSZTOF SROKA 2021-01-28

POWER INPUT TEST (SINGLE PHASE RATED OVER 120V): (CONT'D)
 RATING (CSA 22.2 109-17):

UL 197 Sec. 47
 (6.2)

RESULTS (CONT'D)

RAPID COOK OVEN:

Operating Conditions	Specified				Measured			
	Volts, L1-L2	Amps		Power, W	Volts, L1-L2	Amps		Power, W
		L1	L2			L1	L2	
Rapid Cook Oven, full power operation, rated voltage	240	---	---	---	240	22.7	22.7	4647
Rapid Cook Oven, full power operation, rated current	---	22.6	22.6	---	237	22.6	22.6	4460
Rapid Cook Oven, full power operation, rated power	---	---	---					
c-UL Test Conditions								
Rapid Cook Oven, full power operation, increased test voltage	250	---	---	---	250	23.6	23.6	4991
Rapid Cook Oven, full power operation, increased test current	---	23.3 +	23.3 +	---	250	23.3	23.3	5180
Rapid Cook Oven, full power operation, increased test power	---	---	---					

+ Only the resistive heating elements, and not the microwave power, were used for this calculation.

CONVECTION OVEN:

Operating Conditions	Specified				Measured			
	Volts, L1-L2	Amps		Power, W	Volts, L1-L2	Amps		Power, W
		L1	L2			L1	L2	
Convection Oven, full power operation, rated voltage	240	---	---	---	240	33.5	33.5	8272
Convection Oven, full power operation, rated current	---	33.0	33.0	---	245	33.0	33.0	8495
Convection Oven, full power operation, rated power	---	---	---					
c-UL Test Conditions								
Convection Oven, full power operation, increased test voltage	250	---	---	---	250	36.4	36.4	9651
Convection Oven, full power operation, increased test current	---	34.4	34.4	---	248	34.4	34.4	8619
Convection Oven, full power operation, increased test power	---	---	---					

The input current [was] [~~was not~~] between 90% and 105% of the rated input current when the appliance was energized at rated voltage.

The input power [was] [was not] between 90% and 105% of the rated input power when the appliance was energized at rated voltage.

CAPTURE TEST (IMPINGEMENT):

UL 710B Sec. 58

UL 710 Sec. 31

METHOD

The model Plexor series oven cooking appliance was placed under a hood operating at 500 CFM. The impingement oven was placed in the topmost position. Food product as specified below was then used for testing, see Emission Testing for specific details. The cooking area is to be observed for the presence of visible smoke and grease-laden air, and the hood assembly shall completely capture all of the emission as determined by observation.

COOKING PRODUCT

[X] Oven - 12 in. pepperoni pizza (Tombstone, with 18 pepperonis per pizza)

COOKING METHOD

12 in. pepperoni pizza, each cooked for 3 minutes 00 seconds with 0 seconds between loads for 8 hours (total of 146 pizzas). Oven was set to maintain 500°F with top blower set to 100% and bottom blower set to 35%.

RESULTS

There ~~[was]~~ [was not] the presence of visible smoke and grease-laden air from the appliance during testing.

The sample [did] ~~[did not]~~ capture all of the emissions from the cooking appliance.

CAPTURE TEST (RAPID COOK):

UL 710B Sec. 58

UL 710 Sec. 31

METHOD

The model Plexor series oven cooking appliance was placed under a hood operating at 500 CFM. The rapid cook oven was placed in the topmost position. Food product as specified below was then used for testing, see Emission Testing for specific details. The cooking area is to be observed for the presence of visible smoke and grease-laden air, and the hood assembly shall completely capture all of the emission as determined by observation.

COOKING PRODUCT

[x] Microwave/Convection Oven - 12 in. pepperoni pizza (Tombstone, with 18 pepperonis per pizza)

COOKING METHOD

[Microwave Oven]

12 in. pepperoni pizza,, each cooked for 2 minutes 15 seconds with 0 seconds between loads for 8 hours (total of 183 pizzas). Oven was set to maintain 525°F with Microwave set to 100% and blower set to 90%.

RESULTS

There ~~[was]~~ [was not] the presence of visible smoke and grease-laden air from the appliance during testing.

The sample [did] ~~[did not]~~ capture all of the emissions from the cooking appliance.

Note: During testing the voltage was adjusted to 240v per Barbara Rayle. The voltage adjustment was made because the inverted would overheat and needed to be replaced. KRZYSZTOF SROKA 2021-01-29

CAPTURE TEST (CONVECTION):

UL 710B Sec. 58

UL 710 Sec. 31

METHOD

The model Plexor series oven cooking appliance was placed under a hood operating at 500 CFM. The convection oven was placed in the topmost position. Food product as specified below was then used for testing, see Emission Testing for specific details. The cooking area is to be observed for the presence of visible smoke and grease-laden air, and the hood assembly shall completely capture all of the emission as determined by observation.

COOKING PRODUCT

- Other - As described in the Emission Test.
- For testing ovens, as an alternate, when chicken does not produce visible cooking smoke and grease laden air, one sheet pan (nominal pan size 18 by 26 inches) filled with 1 lb of pork bacon and coated with one cup of sugar distributed evenly is permitted to be used. The pan shall be placed at the lowest location (rack) of the oven, and the oven run at the maximum temperature for 10 minutes.

COOKING METHOD

[Other]

Quartered chickens weighing 2.5 - 3.5 lbs. each. The oven cavity was filled to the maximum capacity of 2.5 chickens, and the chicken was cooked for 25 minutes with 0 seconds between loads for 8 hours (total of 19 loads). Oven was set to maintain 500°F with 100% fan.

+ Note to lab tech: If any chicken pieces are consistently under 165°F, increase to 18 minutes.

RESULTS

There was ~~was not~~ the presence of visible smoke and grease-laden air from the appliance during testing.

The sample did ~~did not~~ capture all of the emissions from the cooking appliance.

EMISSION TEST (IMPINGEMENT):

UL 710B Sec. 59

METHOD

TEST FOR EVOLUTION OF SMOKE OR GREASE-LADEN AIR (500°F):

The model Plexor series oven cooking appliance was placed under a hood operating at 500 CFM, with the impingement module placed in the topmost position. The oven was tested with only the impingement module operating, using a method derived from EPA Method 202.

Note: With the consent of all concerned, a single oven module was tested. If the emission is less than 1/3 of the limit, the modules will be allowed to be stacked with up to three modules in a single enclosure.

UL LLC provided pizzas for the test.

A 12 in. by 6 in. rectangular, 108 in. tall sheet metal stack was constructed on top of the hood. A sampling port was located approximately 80 in. downstream from the hood exhaust, at which point it was determined there was laminar flow. The sampler was assembled and an out of stack filter was used. A pre-leak check was conducted and determined to be < 0.02 ft/min. Sampling was determined to be done at 8 traverse points.

The oven was operated normally by cooking the following foods:

12 in. pepperoni pizza, each cooked for 3 minutes 00 seconds with 0 seconds between loads for 8 hours (total of 146 pizzas). Oven was set to maintain 500°F with top blower set to 100% and bottom blower set to 35%.

Temp	Event #	% Time.	% Top Fan	% Bottom Fan
500°F	1	100	100	35

The cooking cycle was repeated for 8 hours of continuous cooking.

During the cooking operation, it was noted whether or not visible effluents evolved from the air exhaust of the hood. Gauge, meter and temperature readings were taken and recorded every 10 min. After cooking, the condition of the duct was noted and a post-leak check was conducted and determined to be < 0.02 ft³/min.

After being allowed to cool, the sampling equipment is to be disassembled. The glass-filter is to be removed using a pair of forceps and placed in a clean petri dish. The dish is to be sealed and labeled "SAMPLE 1".

A sample of the acetone of the same volume that will be used to rinse-out the nozzle and probe is to be placed into a clean sample bottle, sealed, and labeled "SAMPLE 2". The level of the liquid in the sample bottle is to be recorded.

EMISSION TEST (IMPINGEMENT - CONT'D):

UL 710B Sec. 59

The inside of the nozzle and probe is to be rinsed with acetone taking care to collect all the rinse material in a clean sample bottle. The sample bottle is to be sealed, labeled "SAMPLE 3", and the level of the liquid in the bottle is to be recorded.

The liquid in the first three impingers is to be measured and the total volume is to be recorded which will be compared to the original volume. The liquid is to be quantitatively transferred to a clean sample bottle. Each impinger and the connecting glassware including the probe extension are to be rinsed twice with water. The rinse water is to be collected and added to the same sample bottle. The sample bottle is to be sealed, labeled "SAMPLE 4" and the level of the liquid in the bottle is to be recorded.

This rinse process is to be repeated with two rinses of methylene chloride (MeCl_2). The rinses are to be recovered in a clean sample bottle. The sample bottle is to be sealed, labeled "SAMPLE 5" and the level of the liquid in the bottle is to be recorded.

A volume of water approximately equivalent to the volume of water used to rinse and a volume of MeCl_2 approximately equivalent to the volume of MeCl_2 used to rinse is to be placed in two clean sample bottles. The sample bottles are to be sealed, labeled "SAMPLE 6" and "SAMPLE 7" respectively, and the level of the liquid in the bottles is to be recorded.

The weight of the fourth impinger containing the silica gel is to be recorded and then the silica gel can be discarded.

The analysis phase was done in accordance with EPA Method 202, using the out of stack filter.

RESULTS

The results [are] [~~are not~~] considered acceptable because there [was] [was no] visible smoke emitted from the exhaust of the hood during the normal cooking operation. There [was] [was no] noticeable amounts of smoke accumulated in the test room after 8 hours of continuous cooking.

The total amount of grease-laden effluents collected by the sampling equipment was found to be 1.33 mg/m^3 , which is [less] [~~more~~] than 5 mg/m^3 . +

The total grease emissions (per clause 78.2 of 710B) in pounds per hour per linear food of hood was $0.000665 \text{ lb/hr/ft}$.

Note: Stack avg humidity and temperature;

Stack temperature; 82.6°F

HUMIDITY INSIDE STACK; 19.2%

Note: Additional spreadsheet is to be used when conducting the Emission Test. This spreadsheet (EPA 202) can be found in the Lab Equipment Management System (LEM) under global ID 58255.

+Note: With the consent of all concerned, a single oven module was tested. If the emission is less than 1/3 of the limit, the ovens will be allowed to be stacked with up to three oven modules in a single enclosure.

EMISSION TEST (IMPINGEMENT - CONT'D):

UL 710B Sec. 59

CONDENSIBLE MATTER
(Lab Analysis)

Sample Bottle No.	Description	Volume, ml	Final Wt, mg
2	Acetone (Blank)	100.0	0.3
3	Acetone (Wash)	100.0	0.7
4&5	Solvent Phase (Wash)	110.0	4.2
4&5	Water Phase (Wash)	260.0+270.0=530.0	5.0
6&7	Solvent Phase (Blank)	110.0	0.5
6&7	Water Phase (Blank)	270.0	3.3

Filter paper weight before test- 597.9 mg

Filter paper weight after test- 603.0 mg

Analysis

1. The liquid level of all the sample bottles is to be measured.
2. The filter from sample ONE is to be removed and dried to constant weight by means of a desiccator or an oven. The weight of the filter is to be recorded.
3. The volume of sample TWO is to be determined. The liquid is then to be transferred to a beaker and evaporated to dryness. The volume of the liquid and the final weight of the condensable matter are to be recorded.
4. The volume of sample THREE is to be determined. The liquid is then to be transferred to a beaker and evaporated to dryness. The volume of the liquid and the final weight of the condensable matter are to be recorded.
5. The volumes of sample FOUR and FIVE are to be measured.
6. Samples FOUR and FIVE are to be combined. The solvent phase is to be mixed, separated, and then repeated with two MeCl₂ washes.
7. The solvent extracts obtained from the procedure in 6 are to be placed in a beaker and evaporated to a constant weight. The final weight is to be recorded.
8. The water phase is to be placed in a beaker and evaporated to dryness. The final weight is to be recorded.
9. The volumes of samples SIX and SEVEN are to be determined. Sample bottles SIX and SEVEN are to be analyzed according to procedures 8 and 7 respectively.

EMISSION TEST (RAPID COOK):

UL 710B Sec. 59

METHOD

TEST FOR EVOLUTION OF SMOKE OR GREASE-LADEN AIR (525°F):

The model Plexor series oven cooking appliance was placed under a hood operating at 500 CFM, with the Rapid Cook module in the topmost position. The oven was tested with only the Rapid Cook module operating, using a method derived from EPA Method 202.

Note: With the consent of all concerned, a single oven module was tested. If the emission is less than 1/3 of the limit, the modules will be allowed to be stacked with up to three modules in a single enclosure.

UL LLC provided Pepperoni Pizzas for the test.

A 12 in. by 6 in. rectangular, 108 in. tall sheet metal stack was constructed on top of the hood. A sampling port was located approximately 80 in. downstream from the hood exhaust, at which point it was determined there was laminar flow. The sampler was assembled and an out of stack filter was used. A pre-leak check was conducted and determined to be < 0.02 ft/min. Sampling was determined to be done at 8 traverse points.

The oven was operated normally by cooking the following foods:

[Microwave Oven]

12 in. pepperoni pizza,, each cooked for 2 minutes 15 seconds with 0 seconds between loads for 8 hours (total of 183 pizzas). Oven was set to maintain 525°F with Microwave set to 100% and blower set to 90%.

Temp	Event #	% Time.	% Blower Fan	% Microwave Energy
525 °F	1	100	90	100
	2			
	3			
	4			

The cooking cycle was repeated for 8 hours of continuous cooking.

During the cooking operation, it was noted whether or not visible effluents evolved from the air exhaust of the hood. Gauge, meter and temperature readings were taken and recorded every 10 min. After cooking, the condition of the duct was noted and a post-leak check was conducted and determined to be < 0.02 ft³/min.

After being allowed to cool, the sampling equipment was disassembled. The glass-filter is to be removed using a pair of forceps and placed in a clean petri dish. The dish is to be sealed and labeled "SAMPLE 1".

A sample of the acetone of the same volume that will be used to rinse-out the nozzle and probe is to be placed into a clean sample bottle, sealed, and labeled "SAMPLE 2". The level of the liquid in the sample bottle is to be recorded.

EMISSION TEST (RAPID COOK - CONT'D):

UL 710B Sec. 59

The inside of the nozzle and probe is to be rinsed with acetone taking care to collect all the rinse material in a clean sample bottle. The sample bottle is to be sealed, labeled "SAMPLE 3", and the level of the liquid in the bottle is to be recorded.

The liquid in the first three impingers is to be measured and the total volume is to be recorded which will be compared to the original volume. The liquid is to be quantitatively transferred to a clean sample bottle. Each impinger and the connecting glassware including the probe extension are to be rinsed twice with water. The rinse water is to be collected and added to the same sample bottle. The sample bottle is to be sealed, labeled "SAMPLE 4" and the level of the liquid in the bottle is to be recorded.

This rinse process is to be repeated with two rinses of methylene chloride (MeCl_2). The rinses are to be recovered in a clean sample bottle. The sample bottle is to be sealed, labeled "SAMPLE 5" and the level of the liquid in the bottle is to be recorded.

A volume of water approximately equivalent to the volume of water used to rinse and a volume of MeCl_2 approximately equivalent to the volume of MeCl_2 used to rinse is to be placed in two clean sample bottles. The sample bottles are to be sealed, labeled "SAMPLE 6" and "SAMPLE 7" respectively, and the level of the liquid in the bottles is to be recorded.

The weight of the fourth impinger containing the silica gel is to be recorded and then the silica gel can be discarded.

The analysis phase was done in accordance with EPA Method 202, using the out of stack filter.

RESULTS

The results [are] [~~are not~~] considered acceptable because there [was] [was no] visible smoke emitted from the exhaust of the hood during the normal cooking operation. There [was] [was no] noticeable amounts of smoke accumulated in the test room after 8 hours of continuous cooking.

The total amount of grease-laden effluents collected by the sampling equipment was found to be 1.05 mg/m^3 , which is [less] [~~more~~] than 5 mg/m^3 . +

The total grease emissions (per clause 78.2 of 710B) in pounds per hour per linear food of hood was $0.000518 \text{ lb/hr/ft}$.

Note: Stack avg humidity and temperature;
Stack temperature; 82.3°F
HUMIDITY INSIDE STACK; 27.2%

Note: Additional spreadsheet is to be used when conducting the Emission Test. This spreadsheet (EPA 202) can be found in the Lab Equipment Management System (LEM) under global ID 58255.

+ Note: With the consent of all concerned, a single oven module was tested. If the emission is less than 1/3 of the limit, the modules will be allowed to be stacked with up to three modules in a single enclosure.

EMISSION TEST (RAPID COOK - CONT'D):

UL 710B Sec. 59

CONDENSIBLE MATTER
(Lab Analysis)

Sample Bottle No.	Description	Volume, ml	Final Wt, mg
2	Acetone (Blank)	110.0	0.0
3	Acetone (Wash)	110.0	0.3
4&5	Solvent Phase (Wash)	210.0	2.7
4&5	Water Phase (Wash)	270.0+220.0=490.0	3.6
6&7	Solvent Phase (Blank)	210.0	0.1
6&7	Water Phase (Blank)	220.0	3.1

Filter paper weight before test- 602.8 mg

Filter paper weight after test- 608.9 mg

Analysis

1. The liquid level of all the sample bottles is to be measured.
2. The filter from sample ONE is to be removed and dried to constant weight by means of a desiccator or an oven. The weight of the filter is to be recorded.
3. The volume of sample TWO is to be determined. The liquid is then to be transferred to a beaker and evaporated to dryness. The volume of the liquid and the final weight of the condensable matter are to be recorded.
4. The volume of sample THREE is to be determined. The liquid is then to be transferred to a beaker and evaporated to dryness. The volume of the liquid and the final weight of the condensable matter are to be recorded.
5. The volumes of sample FOUR and FIVE are to be measured.
6. Samples FOUR and FIVE are to be combined. The solvent phase is to be mixed, separated, and then repeated with two MeCl₂ washes.
7. The solvent extracts obtained from the procedure in 6 are to be placed in a beaker and evaporated to a constant weight. The final weight is to be recorded.
8. The water phase is to be placed in a beaker and evaporated to dryness. The final weight is to be recorded.
9. The volumes of samples SIX and SEVEN are to be determined. Sample bottles SIX and SEVEN are to be analyzed according to procedures 8 and 7 respectively.

EMISSION TEST (CONVECTION):

UL 710B Sec. 59

METHOD

TEST FOR EVOLUTION OF SMOKE OR GREASE-LADEN AIR (500°F):

The model Plexor series oven cooking appliance was placed under a hood operating at 500 CFM, with the Convection module placed in the topmost position. The oven was tested with only the Convection Module operating, using a method derived from EPA Method 202.

Note: With the consent of all concerned, a single oven module was tested. If the emission is less than 1/3 of the limit, the modules will be allowed to be stacked with up to three modules in a single enclosure.

UL LLC provided the food load for the test.

A 12 in. by 6 in. rectangular, 108 in. tall sheet metal stack was constructed on top of the hood. A sampling port was located approximately 80 in. downstream from the hood exhaust, at which point it was determined there was laminar flow. The sampler was assembled and an out of stack filter was used. A pre-leak check was conducted and determined to be < 0.02 ft/min. Sampling was determined to be done at 8 traverse points.

The oven was operated normally by cooking the following foods:

[Other]

Quartered chickens weighing 2.5 - 3.5 lbs. each. The oven cavity was filled to the maximum capacity of 2.5 chickens, and the chicken was cooked for 25 minutes with 0 seconds between loads for 8 hours (total of 19 loads). Oven was set to maintain 500°F with 100% fan.

+ Note to lab tech: If any chicken pieces are consistently under 165°F, increase cook time to 18 minutes.

The cooking cycle was repeated for 8 hours of continuous cooking. The total number of loads cooked was: 19

During the cooking operation, it was noted whether or not visible effluents evolved from the air exhaust of the hood. Gauge, meter and temperature readings were taken and recorded every 10 min. After cooking, the condition of the duct was noted and a post-leak check was conducted and determined to be < 0.02 ft³/min.

After being allowed to cool, the sampling equipment is to be disassembled. The glass-filter is to be removed using a pair of forceps and placed in a clean petri dish. The dish is to be sealed and labeled "SAMPLE 1".

A sample of the acetone of the same volume that will be used to rinse-out the nozzle and probe is to be placed into a clean sample bottle, sealed, and labeled "SAMPLE 2". The level of the liquid in the sample bottle is to be recorded.

EMISSION TEST (CONVECTION - CONT'D):

UL 710B Sec. 59

The inside of the nozzle and probe is to be rinsed with acetone taking care to collect all the rinse material in a clean sample bottle. The sample bottle is to be sealed, labeled "SAMPLE 3", and the level of the liquid in the bottle is to be recorded.

The liquid in the first three impingers is to be measured and the total volume is to be recorded which will be compared to the original volume. The liquid is to be quantitatively transferred to a clean sample bottle. Each impinger and the connecting glassware including the probe extension are to be rinsed twice with water. The rinse water is to be collected and added to the same sample bottle. The sample bottle is to be sealed, labeled "SAMPLE 4" and the level of the liquid in the bottle is to be recorded.

This rinse process is to be repeated with two rinses of methylene chloride (MeCl_2). The rinses are to be recovered in a clean sample bottle. The sample bottle is to be sealed, labeled "SAMPLE 5" and the level of the liquid in the bottle is to be recorded.

A volume of water approximately equivalent to the volume of water used to rinse and a volume of MeCl_2 approximately equivalent to the volume of MeCl_2 used to rinse is to be placed in two clean sample bottles. The sample bottles are to be sealed, labeled "SAMPLE 6" and "SAMPLE 7" respectively, and the level of the liquid in the bottles is to be recorded.

The weight of the fourth impinger containing the silica gel is to be recorded and then the silica gel can be discarded.

The analysis phase was done in accordance with EPA Method 202, using the out of stack filter.

RESULTS

The results ~~[are]~~ [are not] considered acceptable because there [was] ~~[was no]~~ visible smoke emitted from the exhaust of the hood during the normal cooking operation. There [was] ~~[was no]~~ noticeable amounts of smoke accumulated in the test room after 8 hours of continuous cooking.

The total amount of grease-laden effluents collected by the sampling equipment was found to be 6.24 mg/m^3 , which is ~~[less]~~ [more] than 5 mg/m^3 . +

The total grease emissions (per clause 78.2 of 710B) in pounds per hour per linear food of hood was $0.003134 \text{ lb/hr/ft}$.

Note: Stack avg humidity and temperature;
Stack temperature; 82.2°F
HUMIDITY INSIDE STACK; 30.4%

Note: Additional spreadsheet is to be used when conducting the Emission Test. This spreadsheet (EPA 202) can be found in the Lab Equipment Management System (LEM) under global ID 58255.

+ Note: With the consent of all concerned, a single oven module was tested. If the emission is less than 1/3 of the limit, the ovens will be allowed to be stacked with up to three oven modules in a single enclosure.

EMISSION TEST (CONVECTION - CONT'D):

UL 710B Sec. 59

CONDENSIBLE MATTER
(Lab Analysis)

Sample Bottle No.	Description	Volume, ml	Final Wt, mg
2	Acetone (Blank)	100.0	0.1
3	Acetone (Wash)	100.0	1.6
4&5	Solvent Phase (Wash)	220.0	15.0
4&5	Water Phase (Wash)	290.0+310.0=600.0	11.6
6&7	Solvent Phase (Blank)	220.0	0.1
6&7	Water Phase (Blank)	310.0	0.3

Filter paper weight before test- 596.1 mg

Filter paper weight after test- 622.2 mg

Analysis

1. The liquid level of all the sample bottles is to be measured.
2. The filter from sample ONE is to be removed and dried to constant weight by means of a desiccator or an oven. The weight of the filter is to be recorded.
3. The volume of sample TWO is to be determined. The liquid is then to be transferred to a beaker and evaporated to dryness. The volume of the liquid and the final weight of the condensable matter are to be recorded.
4. The volume of sample THREE is to be determined. The liquid is then to be transferred to a beaker and evaporated to dryness. The volume of the liquid and the final weight of the condensable matter are to be recorded.
5. The volumes of sample FOUR and FIVE are to be measured.
6. Samples FOUR and FIVE are to be combined. The solvent phase is to be mixed, separated, and then repeated with two MeCl₂ washes.
7. The solvent extracts obtained from the procedure in 6 are to be placed in a beaker and evaporated to a constant weight. The final weight is to be recorded.
8. The water phase is to be placed in a beaker and evaporated to dryness. The final weight is to be recorded.
9. The volumes of samples SIX and SEVEN are to be determined. Sample bottles SIX and SEVEN are to be analyzed according to procedures 8 and 7 respectively.

END OF DATASHEET PACKAGE. THIS PAGE INTENTIONALLY LEFT BLANK

UL® (KNLZ)

Emissions by Product

Ventless Requirement: <5.00 mg/m³

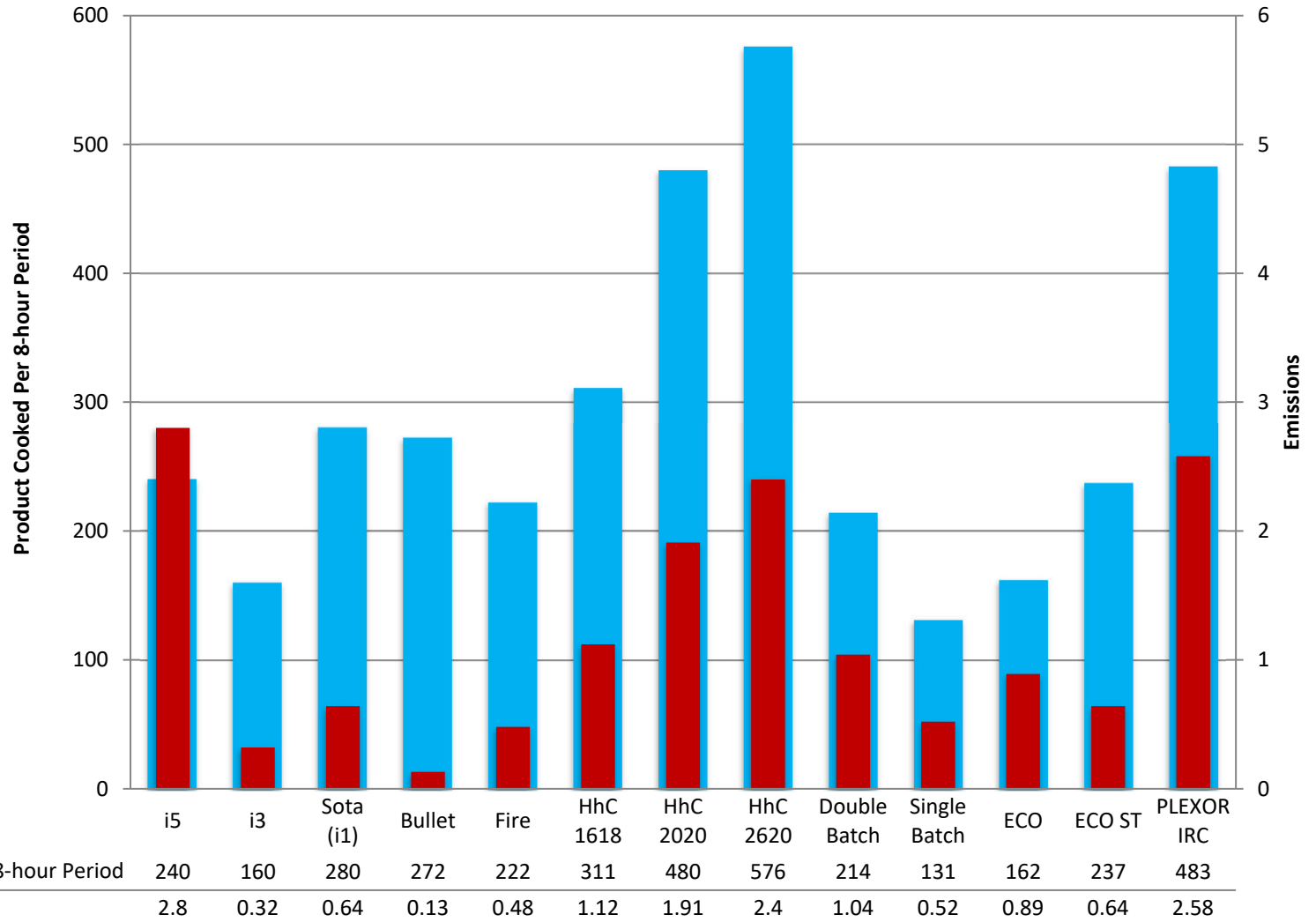

TurboChef Energy Calculator

User Inputs

Total Operation Time per Day (hours)	12	hours	
Cook Cycle Time (seconds)	210	seconds	Average Cook cycle among all 3 modules.
Number of Cooks per Day	100	total	
Energy Cost/kWhr (\$)	0.11	\$/kWhr	

Constants	IRC Plexor
Power Warm-up (watts)	9,200
Power Cooking (watts)	4,700
Power Idle (watts)	2,800
Time Warm-up (seconds)	720

Energy = (Power x time), where power is in watts and time is in seconds

$E_{total} = E_{idle} + E_{cooking} + E_{warmup}$

Ave Power = $E_{total} / \text{total time per day}$

Calculated Times	IRC Plexor
Time (cooking, sec)	21,000
Time (idle, sec)	21,480
Time Check	12
Eidle (kJ)	60,144
Ewarm-up (kJ)	6,624
Ecooking (kJ)	98,700
Etotal (kJ)	165,468
Etotal (kWhr)	45.96
Avg Power/Day (kW)	3.83
Tons of Cooling	1.09
Total Cost/Day (\$)	\$5.06
Total Cost/Month (\$)	\$151.80
Total Cost/Year (\$)	\$1,846.90

PLEXOR Oven Surface Temperatures

This document illustrates the surface temperature testing data reported for the TurboChef PLEXOR oven. Measurements were recorded after two hours of idle. The oven temperature was set to 500°F/260°C for the duration of the test.

After 2-hour Idle at 500°F (Values in °F)

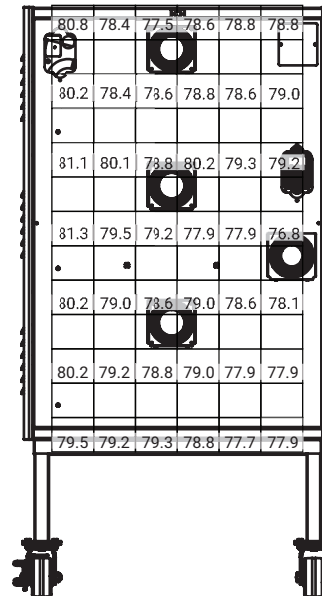
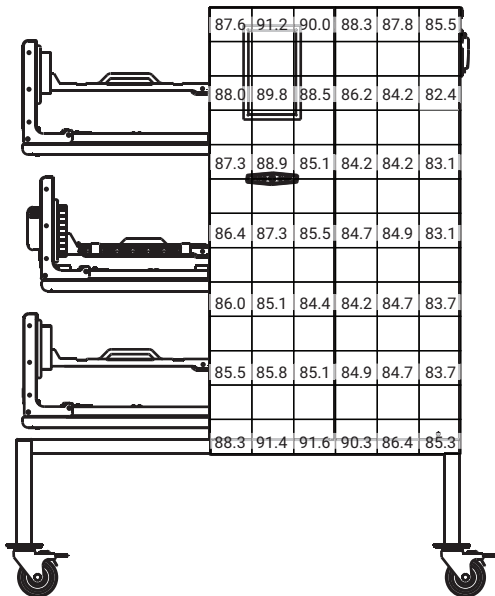
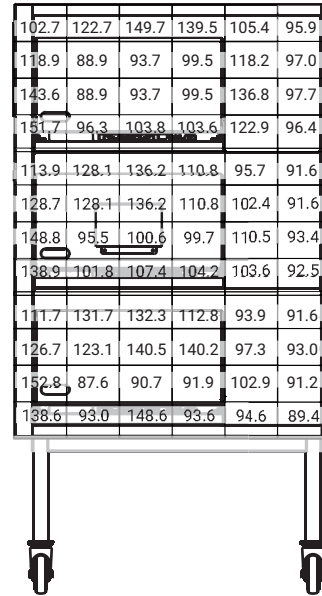
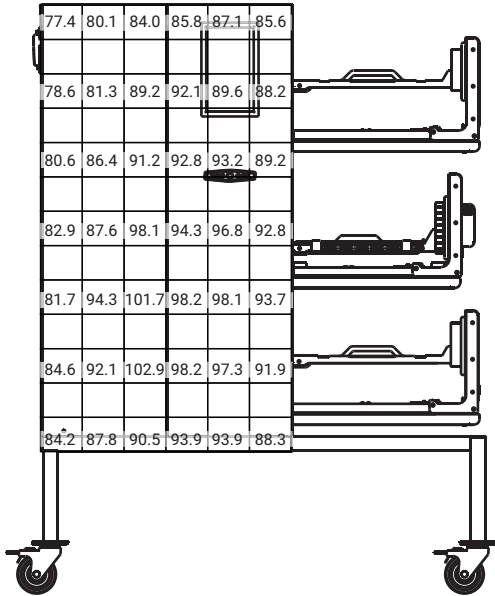

PLEXOR Oven Surface Temperatures

This document illustrates the surface temperature testing data reported for the TurboChef PLEXOR oven. Measurements were recorded after two hours of idle. The oven temperature was set to 500°F/260°C for the duration of the test.

After 2-hour Idle at 260°C (Values in °C)

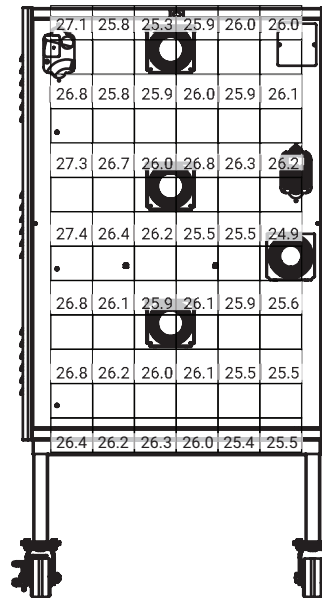
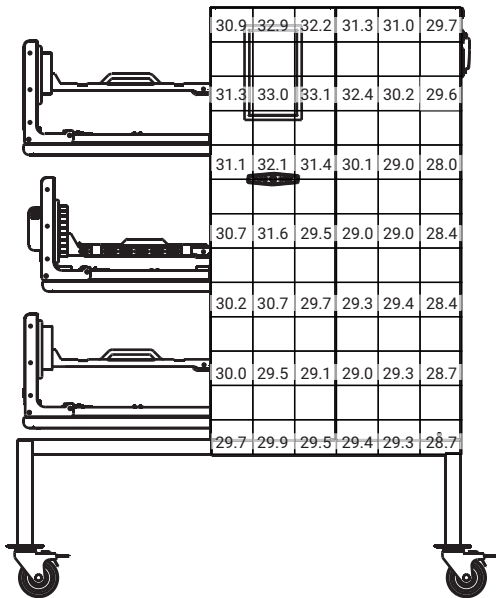
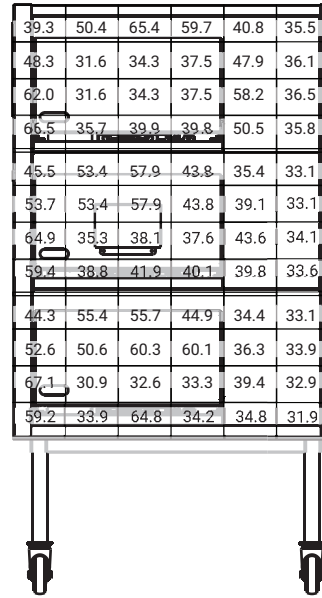
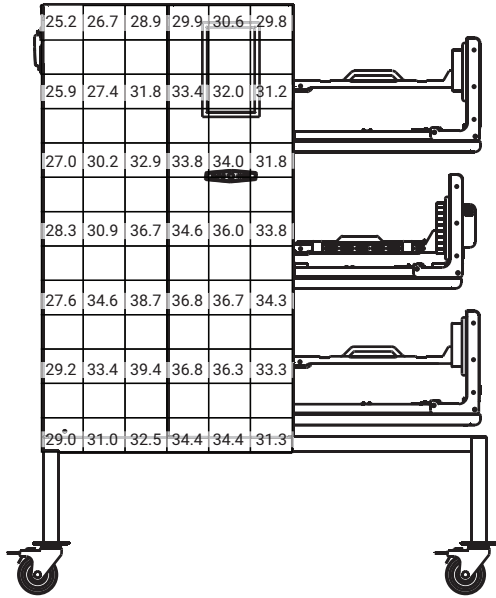

TURBOCHEF TECHNOLOGIES, INC.

Installation Recommendations

TurboChef ventless ovens have internal systems for destroying grease laden vapor prior to the grease escaping the oven; therefore, the ovens are certified as non-grease emitting appliances. When following our recommendations, TurboChef ovens can be installed without the aid of a Type I or Type II hood per International Mechanical Code (2006, 2009, and 2012), NFPA 96, NFPA 101 (Life Safety Code), EPA 202, and Underwriter's Laboratory (UL KNLZ).

The following guide is intended to give relevant information for the ventless installation, operation, and maintenance of TurboChef ovens. It is important that these guidelines are followed and that the oven and surrounding areas be maintained regularly for optimal performance.

Certifications

Safety – cULus, TUV (CE)
 Sanitation – NSF*, UL EPH*
 Ventless – UL (KNLZ)



Electrical Requirements

TurboChef ovens must be installed on a circuit equal to the ratings listed below, per NEC sec 210.23, permissible loads.

Oven	Voltage	Current	Phase
Bullet	208/240 VAC	30 amp	1 Ph
C3	208/240 VAC	50 amp	1 Ph
Double Batch	208/240 VAC 208/240 VAC	50 amp 30 amp	1 Ph 3 Ph
ECO	208/240 VAC	20 amp	1 Ph
ECO ST	208/240 VAC	30 amp	1 Ph
Encore/Encore 2	208/240 VAC	30 amp	1 Ph
Fire	208/240 VAC	30 amp	1 Ph
HhB 2	208/240 VAC	30 amp	1 Ph
HhC 1618	208/240 VAC 208/240 VAC	30 amp 50 amp	3 Ph 1 Ph
HhC 2020	208/240 VAC	50 amp	3 Ph
HhC 2620	208/240 VAC	50 amp	3 Ph
i1 (Panini, Sota/Sota Single Mag, El Bandido, Waterless Steamer)	208/240 VAC	30 amp	1 Ph
i1 Sota Single Mag	208/240 VAC	20 amp	1 Ph
i3	208/240 VAC 208/240 VAC	40 amp 30 amp	1 Ph 3 Ph
i5	208/240 VAC 208/240 VAC	50 amp 30 amp	1 Ph 3 Ph
PLEXOR	208/240 VAC	50 amp	3 Ph
Single Batch	208/240 VAC	30 amp	1 Ph
Tornado	208/240 VAC	30 amp	1 Ph

* NSF certification applies to the Tornado, C3, and HhB 2 ovens only. UL EPH certification applies to all ovens except the C3.

Menu Requirements

TurboChef ovens have been approved by Underwriter's Laboratory for ventless operation (UL KNLZ listing) for all food items EXCEPT for foods classified as "fatty raw proteins." Such foods include bone-in, skin-on chicken, raw hamburger meat, raw bacon, raw sausage, steaks, etc.

The TurboChef certification includes precooked food items such as pizza toppings, sandwich meats, frozen appetizers, and cheeses. Additionally, raw, lean meats such as boneless, skinless chicken breasts and fish fall within the certification.

Cleaning Requirements

To ensure continued compliance with all health, building, and fire codes, users are required to:

- Use only TurboChef-approved cleaning chemicals.
- Follow monthly and quarterly cleaning instructions provided in the manual. Post cleaning instructions near the oven.
- Ventless installation requires that the areas around the oven (walls, ceilings, kitchen equipment, etc.) be cleaned as needed but no less than once every other month.

Installation Near Open Heat Source

When placing a TurboChef oven near an open heat source (see illustration below), strictly adhere to the following:

- If the oven is being placed near a grill or stove, a divider must exist between the oven and the open heat source, with a minimum of 6" (152 mm) between the oven and the divider.
- If the oven is being placed near a fryer, a divider must exist between the oven and fryer, with a minimum of 12" (305 mm) between the oven and the divider.
- The height of the divider must be greater than or equal to the height of the oven.

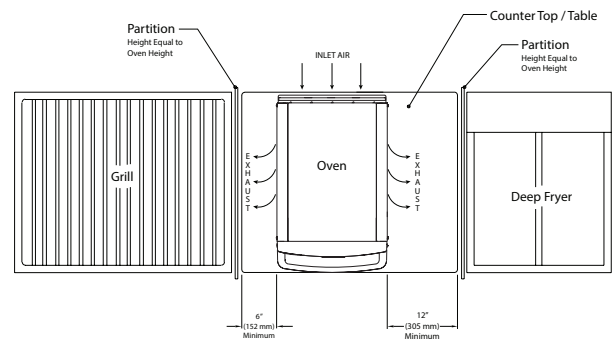

Oven Clearances

Verify the oven location has the following clearances on the top and each side. TurboChef ovens have built-in back bumpers that allow for the necessary spacing from the oven to the back wall.

Oven	Top	Sides
Bullet	5" (127 mm)	2" (51 mm)
C3	4" (102 mm)	2" (51 mm)
Double Batch	2" (51 mm)	2" (51 mm)
ECO	5" (127 mm)	1" (25 mm)
ECO ST	5" (127 mm)	1" (25 mm)
Encore/Encore 2	5" (127 mm)	2" (51 mm)
Fire	2" (51 mm)	2" (51 mm)
HhB 2	2" (51 mm)	2" (51 mm)
HhC 1618	10" (254 mm)	0" (0 mm)
HhC 2020	10" (254 mm)	0" (0 mm)
HhC 2620	10" (254 mm)	0" (0 mm)
i1 (Panini, Sota / Sota Single Mag, El Bandido, Waterless Steamer)	5" (127 mm)	1" (25 mm)
i3	19" (483 mm)	2" (51 mm)
i5	19" (483 mm)	2" (51 mm)
PLEXOR	0" (0 mm)	0" (0 mm)
Single Batch	2" (51 mm)	2" (51 mm)
Tornado	4" (102 mm)	2" (51 mm)

Ventilation

TurboChef ovens must be installed in a well-ventilated space. The space should have an exhaust rate of .70 cfm per square foot of kitchen space and an additional 100 sq. ft. (9.3 m²) of virtual space per ventless cooking appliance (TurboChef or any other).

If the air inlet is for general exhaust, pursuant to requirements for 507.2.2, paragraph 2, locate the air inlet above the center point of each oven.

The heat load from TurboChef ovens is mostly sensible. The only latent heat present is due to evaporation during the cooking process. When installing a TurboChef oven, the space must have the following tons of AC per oven installed.

Oven	Tons of AC
Bullet	0.5
C3	0.63
Double Batch	1.15
ECO	0.89
ECO ST	0.28
Encore/Encore 2	0.45
Fire	0.55
HhB 2	0.84
HhC 1618	1.00
HhC 2020	1.47

HhC 2620	1.82
i1 (Panini, Sota/Sota Single Mag, El Bandido, Waterless Steamer)	0.3
i3	0.9
i5	1.3
PLEXOR	1.09
Single Batch	0.75
Tornado	0.58

How the Ovens are Tested

TurboChef ovens are evaluated according to UL. The evaluation entails placing the test oven in an environmental chamber built to capture all emissions escaping during idle, cooking, and door-open conditions. During the eight-hour test period, a typical worst-case food item is cooked continuously, and 100% of condensable and non-condensable emissions from the product are collected and analyzed according to the EPA 202 Test Method. At the conclusion of the test, the total concentration of particulate matter (emissions) must be less than 5.0 mg/m³ for the oven to be certified for ventless operation. Cooking devices that measure above the 5.0 mg/m³ threshold are considered to produce grease and must be installed under Type I ventilation, according to International Mechanical Code.

TurboChef ovens are well below the 5.0 mg/m³ threshold as shown below.

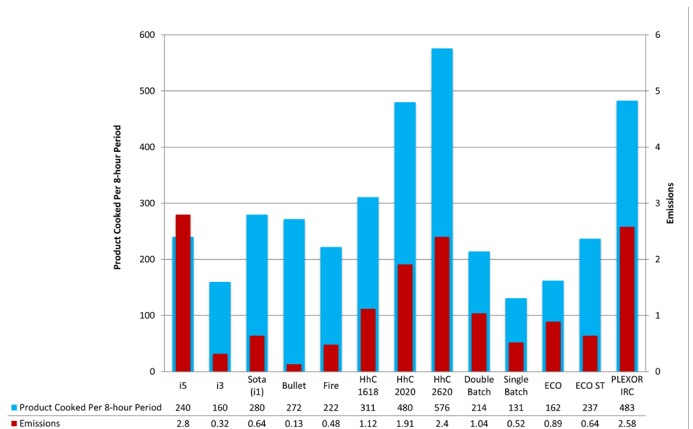

Contact Information

For questions regarding a ventless installation, email ventless.help@turbochef.com. For questions or concerns regarding an existing installation, contact Customer Service at 1.800.908.8726, Option 1.