



BEVERAGE-AIR

Project: _____
 Item: _____
 Location: _____
 Approved: _____

AIA#

SIS#

FOOD PREPARATION TABLES

DP60HC Deli/Pizza Two Door Prep Table

Hydrocarbon Series

MODEL:
DP60HC

DP60HC FOOD PREPARATION: DELI/PIZZA PREP SERIES



7 Year Parts/Labor Warranty
7 Year Compressor Warranty

CABINET CONSTRUCTION

- Stainless steel front, sides, top, doors, and grille (galvanized back & bottom)
- Interior liner is made of corrosion resistant aluminum
- Aluminum top interior liner prevents spill from falling into cabinet
- Stainless steel top
- Removable hoods and insulated lid assemblies are made of matching stainless steel
- Self-closing doors with 120° stay-open feature, on lift-off hinges
- Snap-in door gaskets
- Easy lift-off door removal for service and cleaning
- Field reversible door
- 3" Casters, 2 with brakes standard
- 19" Wide reversible cutting board constructed of white polyethylene plastic
- Cutting board removable for cleaning
- Four (4) epoxy-coated steel wire shelves
- Units will accept pans up to 6" deep (pans are not included)
- Compressor available on left or right, specify at time of unit order

OPTIONS & ACCESSORIES

- Stainless steel back
- Stainless steel interior
- Clear lid
- Combination door/drawer models
- Overshelf kits
- Additional shelves
- Shelf clips
- Pan support
- Door locks
- Composite cutting board
- Thermometer
- Night cover
- Bun tray rack
- 6" Casters
- 6" Legs black or seismic/flanged
- Remote option* (see note on back page)

REFRIGERATION SYSTEM

- Uses environmentally friendly, energy efficient R290 refrigerant, and meets all regulatory requirements for CARB, SNAP, DOE & more
- Adaptive defrost
- Epoxy coated evaporator coil
- Enhanced airflow maintains temperatures between 36° - 38°F



Please verify qualifying units by visiting:
www.energystar.gov/cfs

3779 Champion Blvd., Winston-Salem, NC 27105
1-888-845-9800 Fax: 1-336-245-6453
Beverage-Air.com Sales@bevair.com



BEVERAGE-AIR

MODEL	DP60HC
EXTERNAL DIMENSIONAL DATA	
Width Overall	60"
Depth Overall with Cutting Board	37"
Height Overall with Casters & Lid Open	53 1/4"
No. of Doors	2
Depth with Door Open 90°	52 1/8"
Door Openings	18 5/8" x 23 5/8"
Depth, Cutting Board	19"
INTERNAL DIMENSIONAL DATA	
NET Capacity (cubic ft.)	17
Internal Width Overall (in)	56"
Internal Width Usable (in)	41"
Internal Depth Overall (in)	26"
Internal Height Overall (in)	23 3/4"
No. of Shelves	4
ELECTRICAL DATA	
Full Load Amperes	4.5
REFRIGERATION DATA	
Horsepower	1/2
Capacity (BTU/Hr)	2940
Heat Rejection (BTU/Hr)	4410
Charge (lbs/grams/ounces)	0.231 / 105 / 3.7
SHIPPING DATA	
Gross Weight - Crated	412 lbs
Height - Crated	49"
Width - Crated	70"
Depth - Crated	37"

*NOTE: Remote units are field wired and come with 6" legs. Refrigerant must be specified at time of order.

We reserve the right to change specifications and product design without notice. Such revisions do not entitle the buyer to corresponding changes, improvements, additions or replacements for previously purchased equipment. Dimensional tolerances +/- 1/4". Metric dimensions (MM).

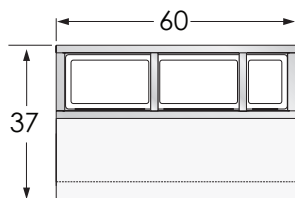

Top Configuration

Deli/Pizza Preparation Table Model: DP60HC

Model Views

Required Clearance: 2" Bottom & 2" Rear

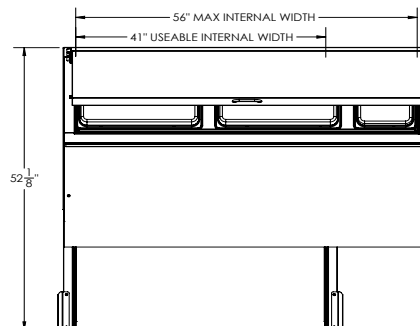

PLAN VIEW

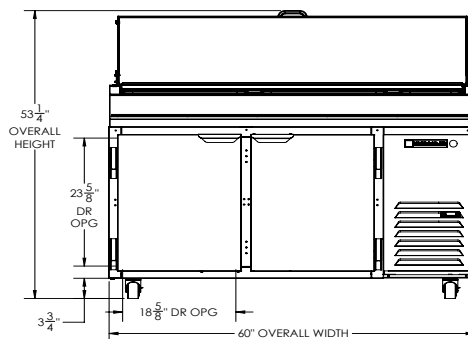

ELEVATION VIEW

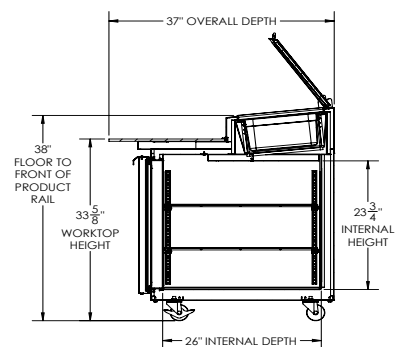

SIDE VIEW

ELECTRICAL CONNECTION



115/60/1
NEMA 5-15P

Unit pre-wired at factory and include 8' long cord and plug set.



3779 Champion Blvd., Winston-Salem, NC 27105 1-888-845-9800 Fax: 1-336-245-6453 Beverage-Air.com Sales@bevoir.com

