



BEVERAGE-AIR

Project: _____	AIA#
Item: _____	
Location: _____	SIS#
Approved: _____	

SPE27HC SANDWICH PREP: SNEEZE GUARD

FOOD PREPARATION TABLES

SPE27HC Sandwich Prep Table With Sneeze Guard Hydrocarbon Series

MODEL:
SPE27HC-SNZ



7 Year Parts/Labor Warranty
7 Year Compressor Warranty

CABINET CONSTRUCTION

- Stainless steel front, sides, top, door and grille (galvanized back & bottom)
- Interior liner is made of corrosion resistant aluminum
- Full electronic control
- Sneeze guard top
- Airflow assures that product in open containers is kept below 41°F and above freezing
- Self-closing door with 120° stay-open feature on cartridge style hinges
- Snap-in magnetic gaskets for positive door seal
- Painted aluminum door handle
- 6" Casters, 2 with brakes standard
- 10" Wide cutting board constructed of white polyethylene plastic
- Cutting board removable for cleaning
- Two (2) epoxy-coated steel wire shelves
- Eight (8) 1/6 4" deep pans constructed of polycarbonate plastic

OPTIONS & ACCESSORIES

- Stainless steel back
- Stainless steel interior
- Left hinged door (at time of order)
- Door lock
- Overshelves (single or double)
- Crumb catcher kit
- Richlite cutting board
- Night cover
- Epoxy coated shelves
- Shelf clips
- Shelf dividers
- Bottle organizer
- Bun rack
- Pan supports
- Pan support crossbar
- 6" Legs or 3" casters
- Low profile casters
- Remote option* (see note on back page)

REFRIGERATION SYSTEM

- Uses environmentally friendly, energy efficient R290 refrigerant, and meets all regulatory requirements for CARB, SNAP, DOE & more
- Adaptive defrost
- Epoxy coated evaporator coil
- Enhanced airflow maintains temperatures between 36° - 38°F



Please verify qualifying units by visiting:
www.energystar.gov/cfs



3779 Champion Blvd., Winston-Salem, NC 27105
1-888-845-9800 Fax: 1-336-245-6453
Beverage-Air.com Sales@bevair.com



BEVERAGE-AIR

MODEL	SPE27HC-SNZ
EXTERNAL DIMENSIONAL DATA	
Width Overall	27"
Depth Overall	32 1/8"
Height Overall with Casters	53"
Number Doors	1
Depth with Door Open 90°	55 3/8"
Door Opening	22 5/8" x 21 5/8"
INTERNAL DIMENSIONAL DATA	
NET Capacity (cubic ft.)	6.91
Internal Width Overall (in)	23"
Internal Depth Overall (in)	23 1/2"
Internal Height Usable (in)	23"
No. of Shelves	2
No. of Pans	8
ELECTRICAL DATA	
Full Load Amperes	2.0
REFRIGERATION DATA	
Horsepower	1/10
Capacity (BTU/Hr)	1110
Heat Rejection (BTU/Hr)	1665
Charge (lbs/grams/ounces)	0.1102 / 50 / 1.76
SHIPPING DATA	
Gross Weight - Crated	227 lbs
Height - Crated	46"
Width - Crated	30"
Depth - Crated	33"

*NOTE: Remote units are field wired and come with 6" legs.
Refrigerant must be specified at time of order.

We reserve the right to change specifications and product design without notice. Such revisions do not entitle the buyer to corresponding changes, improvements, additions or replacements for previously purchased equipment. Dimensional tolerances +/- 1/4". Metric dimensions (MM).

Food Preparation Table: With Sneeze Guard Model: SPE27HC-SNZ

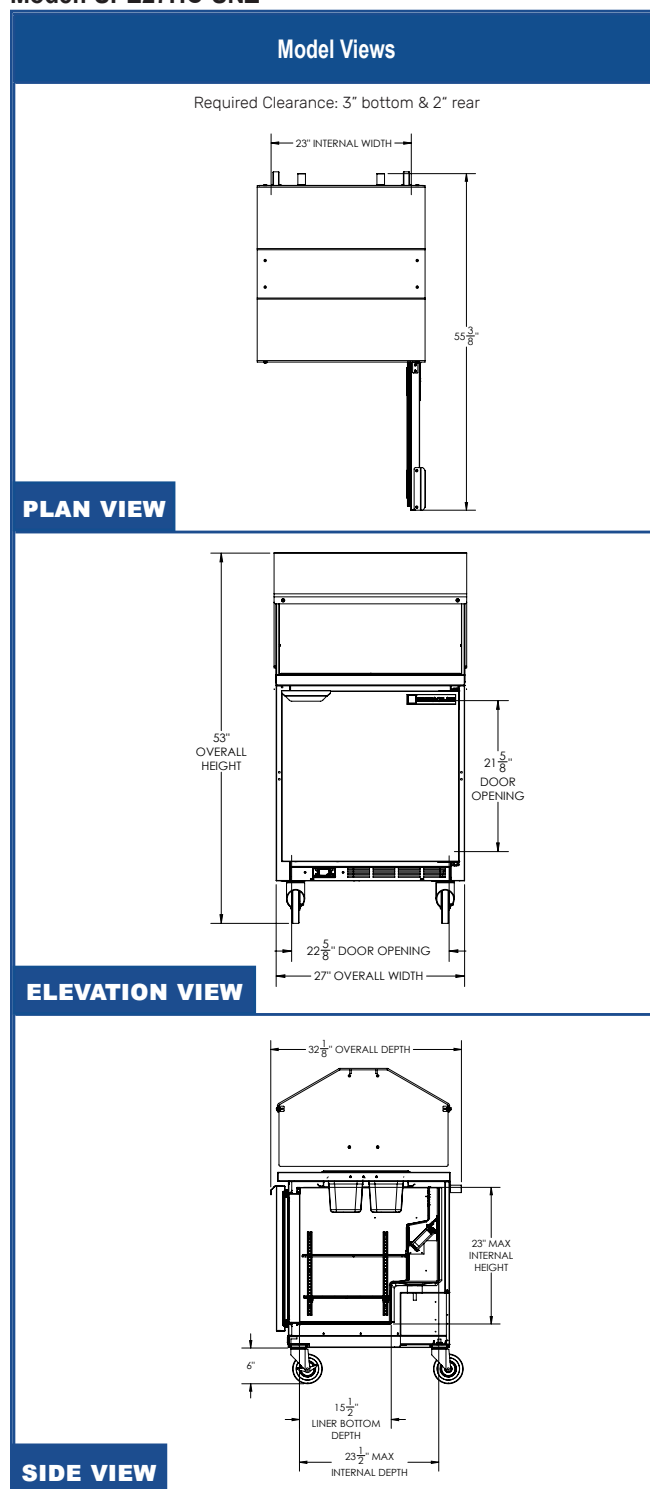

ELECTRICAL CONNECTION

115/60/1
NEMA 5-15P

Unit pre-wired at factory and include 8' long cord and plug set.