



BEVERAGE-AIR®

Project: _____	AIA#
Item: _____	
Location: _____	SIS#
Approved: _____	

RB19HC BOTTOM MOUNT: VISTA® SERIES

VISTA® BOTTOM MOUNT REACH-IN REFRIGERATOR

**MODEL:
RB19HC-1G**

RB19HC Glass Door Reach-In Refrigerator
Hydrocarbon Series



**7 Year Parts/Labor Warranty
7 Year Compressor Warranty**

CABINET CONSTRUCTION

- Stainless steel front and grille, gray painted sides
- Gray painted aluminum interior
- Full electronic control
- LED lighting
- Self-closing door with 120° stay-open feature, on spring-loaded hinges
- One-piece grille allow easy removal/installation for preventative maintenance
- Three (3) heavy duty epoxy coated wire shelves standard
- 6" Casters standard with (2) brakes

OPTIONS & ACCESSORIES

- Epoxy shelves (5 max per section)
- Shelf clips
- 3" Casters or 6" legs
- 6" Flanged/seismic feet
- Door lock
- Remote option* (see note on back page)

REFRIGERATION SYSTEM

- Uses environmentally friendly, energy efficient R290 refrigerant, and meets all regulatory requirements for CARB, SNAP, DOE & more
- Adaptive defrost
- Epoxy coated evaporator coil
- Maintains product temperatures between 36°-38°F



 Please verify qualifying units by visiting:
www.energystar.gov/cfs

3779 Champion Blvd., Winston-Salem, NC 27105
1-888-845-9800 Fax: 1-336-245-6453
Beverage-Air.com Sales@bevair.com



BEVERAGE-AIR

MODEL	RB19HC-1G
EXTERNAL DIMENSIONAL DATA	
Width Overall	27 ¼"
Depth Overall with Handle	27 ½"
Height Overall	84 ⅝"
Number of Doors	1
Depth with Door Open 90°	51 ⅝"
Door Opening (in)	24 ⅙" x 52 ½"
INTERNAL DIMENSIONAL DATA	
NET Capacity (cubic ft.)	19.08
Internal Width Overall (in)	24 ¼"
Internal Depth Overall (in)	22 ½"
Internal Height Overall (in)	61 ¾"
Internal Height Useable (in)	55"
Number of Shelves	3
ELECTRICAL DATA	
Full Load Amperes 115/60/1	2.88
REFRIGERATION DATA	
Horsepower	1/4
Capacity (BTU/Hr)	1702
Heat Rejection (BTU/Hr)	2553
Charge (lbs/grams/ounce)	0.1985 / 90 / 3.18
SHIPPING DATA	
Gross Weight (crated lbs)	302 lbs
Height - Crated	85"
Width - Crated	30"
Depth - Crated	36"

*NOTE: Remote units are field wired and come with 6" legs. Refrigerant must be specified at time of order.

We reserve the right to change specifications and product design without notice. Such revisions do not entitle the buyer to corresponding changes, improvements, additions or replacements for previously purchased equipment. Dimensional tolerances +/- .1/4". Metric dimensions (MM).

VISTA® Bottom Mount Reach-In Refrigerator Model: RB19HC-1G

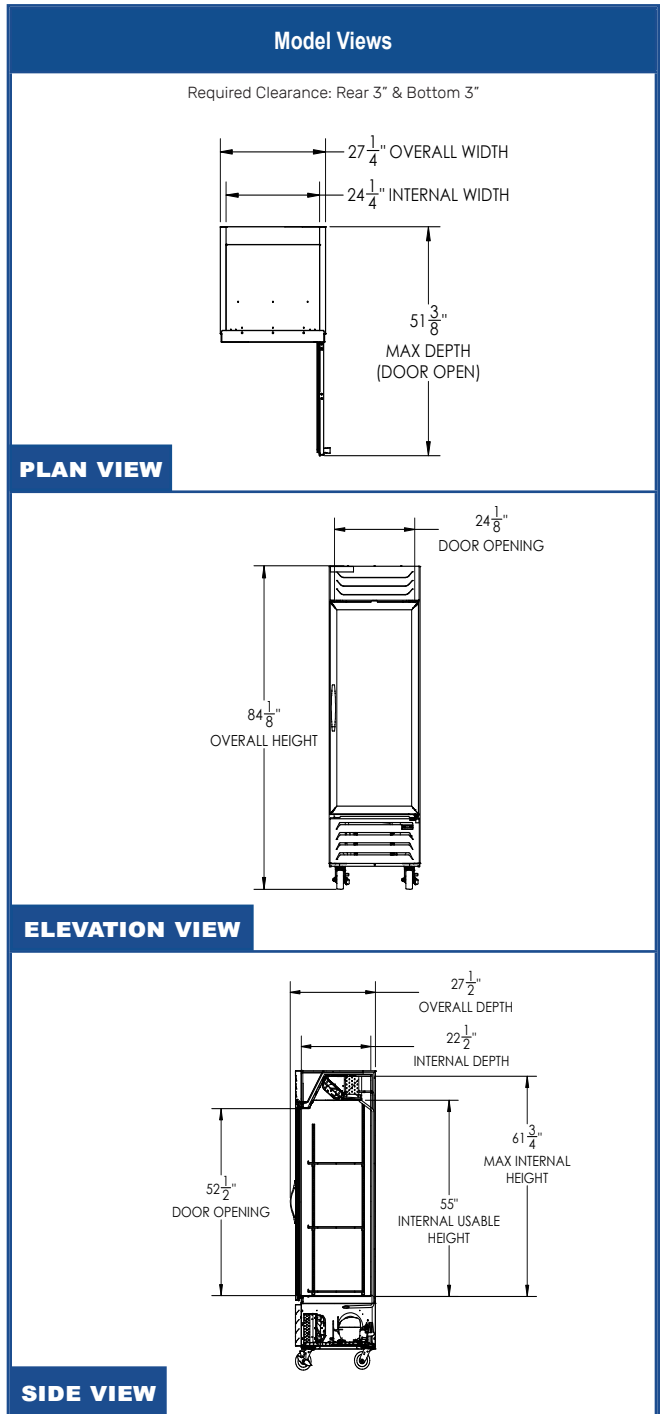

ELECTRICAL CONNECTION



115/60/1
NEMA 5-15P

Unit pre-wired at factory and include 8' long cord and plug set.

